



Order Code

UDB-18GM35-3E2-Y111070

Features

- Ultrasonic system for detection of single sheet, no sheet and double sheet. Also detection of pasted double sheets.
- Weights of paper from 30 g up to cartons weighing over 1200 g can be detected.
- It is also possible to detect thin metal and plastic films.
- Various materials and thicknesses are programmed in via a TEACH-IN signal.
- additional TEACH-IN button on the control interface
- Automatic compensation of the operating point in the case of slowly changing ambient conditions.
- Signal output via short-circuit proof PNP switch outputs.
- Very high processing speeds are possible.

Electrical Connection

Standard symbol/Connection:
Double-sheet-control

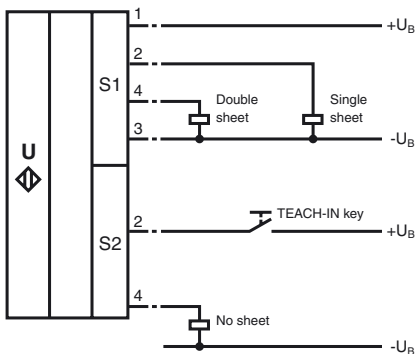

Connector V1



Dimensions

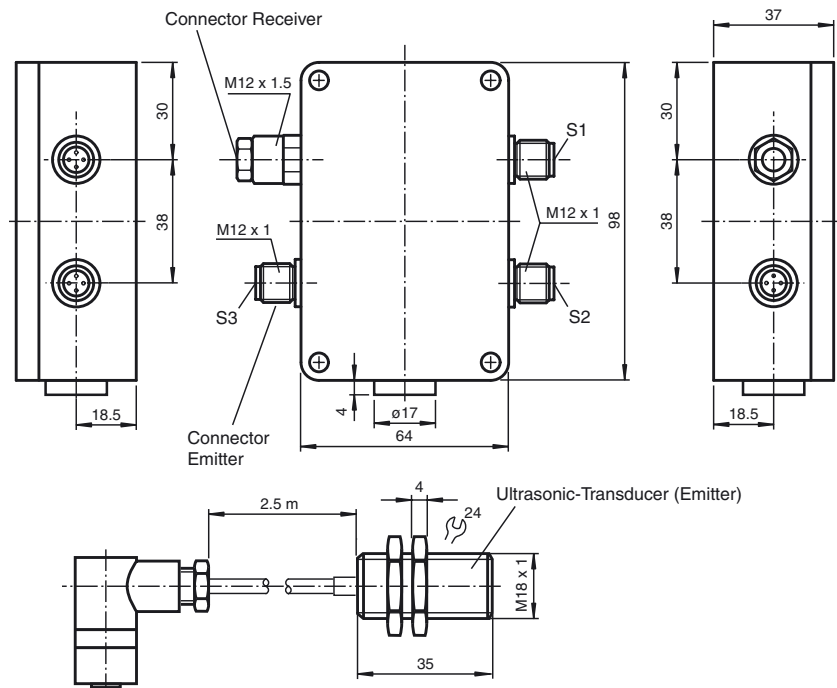

Technical Data

General specifications	
Transducer frequency	180 kHz
Indicators/operating means	
LED green	indication: single sheet detected
LED yellow	indication: no sheet detected
LED red	indication: double sheet or pasted double sheets detected
Electrical specifications	
Operating voltage	20 ... 30 V DC , ripple 10 % _{SS}
No-load supply current I ₀	< 80 mA
Input	
Input type	1 pulse input for Teach-In with Teach-In on analyser unit
Pulse length	≥ 100
Impedance	≥ 10 kOhm
Voltage	12 ... 30 V
Output	
Output type	3 switch outputs pnp, NO
Rated operational current I ₀	3 x 200 mA
Voltage drop U _d	≤ 2 V
Switch-on delay t _{on}	≤ 5 ms
Switch-off delay t _{off}	≤ 5 ms
Standard conformity	
Standards	EN 60947-5-2
Ambient conditions	
Ambient temperature	0 ... 60 °C (273 ... 333 K)
Storage temperature	-40 ... 70 °C (233 ... 343 K)
Mechanical specifications	
Protection degree	IP65
Connection	2 V1 connector (M12x1)
Material	
Housing	Makrolon/nickel-plated brass
Mass	370 g

Release date: 2008-07-25 09:33 Issue date: 2008-07-25 111070_ENG.xml

Notes:

In addition to the printing industry, the ultrasonic double-sheet monitor is deployed in all situations in which the automatic distinction between single and double sheets is required in order to protect machines or avoid waste production.

The double-sheet monitor is based on the ultrasonic through-beam principle. The following can be detected:

- No sheet
- Individual sheet
- Double sheet

A microprocessor system evaluates the signals. The appropriate switch outputs are set as a result of the evaluation. Changes in ambient conditions such as temperature and humidity are automatically compensated. The evaluation electronics are installed in a cuboid plastic housing separate from the sensor heads.

Measuring system:

A complete system consists of an ultrasonic transmitter, an ultrasonic receiver and an evaluation unit. These units have been optimally tuned to one another at the factory and may not be used separately.

Adjustment:

When adjusting the transmitter and receiver, take care to align them as precisely as possible.

- Distance of the sensor heads: $d = 20 \dots 80 \text{ mm}$
- Angular tolerance: $\alpha < \pm 2^\circ$
- Maximum offset: $s < \pm 2 \text{ mm}$

To ensure their correct function, the sensor heads must be aligned at an angle of $20^\circ \dots 45^\circ$ from vertical onto the paper surface. The paper is guided over the transmitter at a distance of $5 \dots 15 \text{ mm}$. The transmitter is installed below in order to prevent dust deposits. Install the sensor heads using the included plastic nuts. The sound lobe must be completely covered by the paper. This means that the sensor heads must be installed above the sheet of paper and at least 10 mm away from the side edge of the paper.

Maximum feed speed of the sheet (approximate value):

$$v_{\max} [\text{m/s}] = \text{Overlapping of sheets} [\text{mm}] / 5 [\text{ms}] (\text{overlapping} > 20 \text{ mm})$$

Teach-In:

Power On

1. After the operating voltage has been applied, a single sheet can be fed in as the first sheet. It will automatically be programmed as a reference value by the system.
2. If a single sheet of paper is located between the ultrasonic transmitter and receiver when the operating voltage is turned on, it will automatically be programmed as a reference value.

Automatic learning for thinner types of sheets

If you are inserting a thinner type of sheet, you can dispense with the use of the Teach-In signal to program the system. In order to do this, a single sheet of paper must be between the transmitter and receiver for at least 10 s .

Automatic learning for thicker types of sheets

If you are inserting a thicker type of sheet but still not one that will result in double-sheet output, you can dispense with learning by means of the Teach-In signal. In order to do this, a single sheet of paper must be between the transmitter and receiver for at least 10 s .

Teach-In for a new type of sheet

If you are inserting a new type of sheet that will result in double-sheet output, the system must be reprogrammed. To do this, a single sheet must be placed between

Characteristic Curves/Additional Information

Characteristic response curves

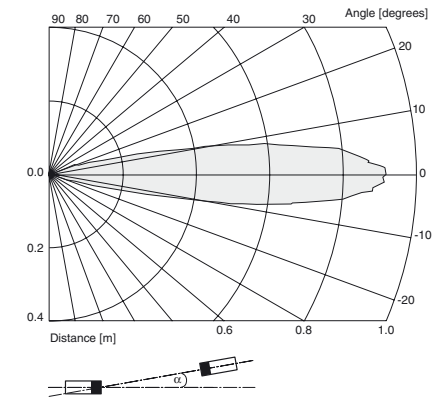

Mounting/Adjustment

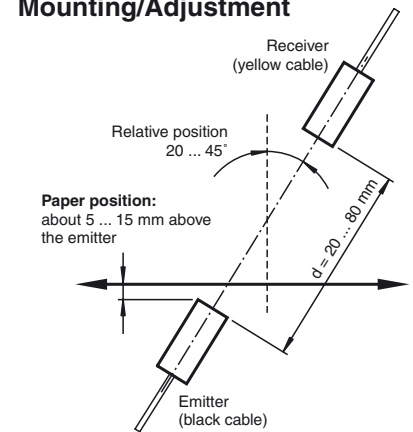

Angular alignment

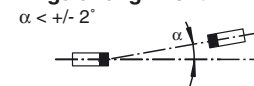

Sensor offset

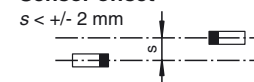

Accessories

UDB-Cable-2M
Accessories

UDB-Cable-1M
Accessories

the transmitter and receiver. After the Teach-In signal has been applied, the corresponding reference value will be accepted.

Caution!

The paper sheets may not touch the sensor heads during operation.

Depending on physical conditions, reflections on the edge of a single sheet may result in double-sheet output. This is not an error, and can be masked out in the higher-level control system.

Sensor systems for ultrasonic double-sheet monitoring can also be delivered with a customized time response for optimal adaptation to specific applications.

Notes:

When installing, care has to be taken that the ultrasonic signal cannot pass around the material that is to be detected, due to multiple reflections. This can happen if large surfaces are present at right angles to the direction of sound propagation. This can be the case if unsuitable mounting brackets are used, or if assemblies with large surface are part of the machine. In the latter case such machine parts should be covered by sound absorbing material or a different location for the installation should be chosen.

In cases where more than one system is needed per machine, acoustic isolation should be provided to avoid cross-talk. This can be provided, for example, by appropriately positioning isolation panels.