



MLV11-8-H-150/48/65a/76b/112

Reflection light scanner with background suppression

MLV11-8-H-150/48/65a/76b/112

with 5-pin M12 connector, 90° adjustable position

CE



- ◆ Sensing range up to 150 mm
- ◆ Visible red light
- ◆ Pre-fault indication
- ◆ Test input
- ◆ Protection degree IP67
- ◆ All materials approved for food industry applications

Date of edition 12/10/03

General specifications

Detection range	0 ... 150 mm
Light source	LED
Approvals	CE
Adjustment range	20 ... 150 mm
Reference target	standard white 100 mm x 100 mm
Light type	red, alternating light
Diameter of the light spot	4 mm at a distance of 80 mm
Ambient light limit	10000 Lux

Indicators/operating means

Operating display	LED green
Function display	LED yellow: switching state LED red flashing pre-fault indicator
Operating elements	sensing range adjuster

Electrical specifications

Operating voltage	10 ... 30 V DC
Ripple	10 %
No-load supply current I_0	≤ 25 mA
Time delay before availability t_v	≤ 80 ms

Input

Test input	emitter deactivation at 0 V
------------	-----------------------------

Output

Switching type	light/dark switching
Signal output	2 switch outputs npn, normally open/closed (complementary)
Switching voltage	max. 30 V DC
Switching current	max. 100 mA
Voltage drop U_d	≤ 2.5 V
Switching frequency f	≤ 1000 Hz
Response time	≤ 0.5 ms

Standard conformity

Standards	EN 60947-5-2
-----------	--------------

Ambient conditions

Ambient temperature	-25 ... 70 °C (248 ... 343 K)
Storage temperature	-40 ... 70 °C (233 ... 343 K)

Mechanical specifications

Protection degree	IP67
Connection	5-pin M12 x 1 connector, 90° adjustable position
Material	
Housing	ABS
Optical face	scratch resistant plastic lens
Mass	40 g



MLV11-8-H-150/48/65a/76b/112

Curves/Diagrams

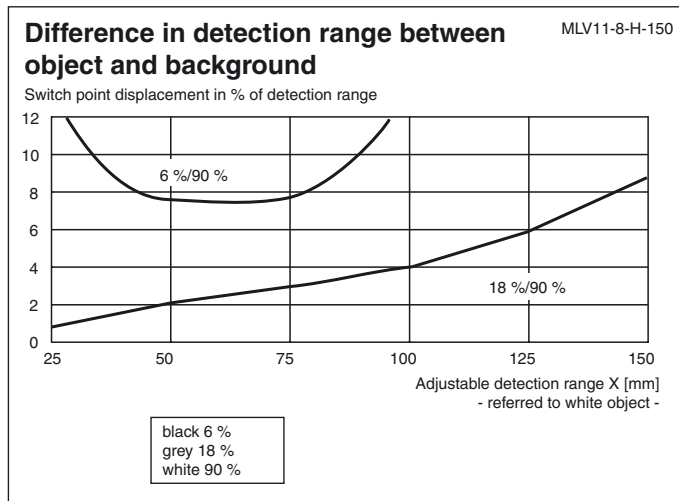
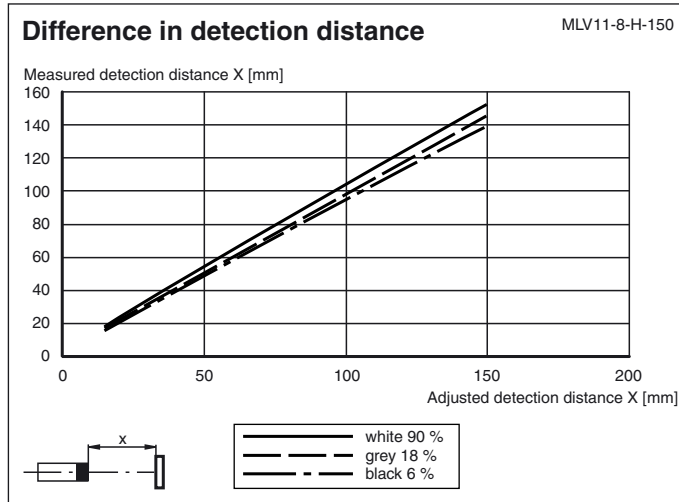

Dimensions

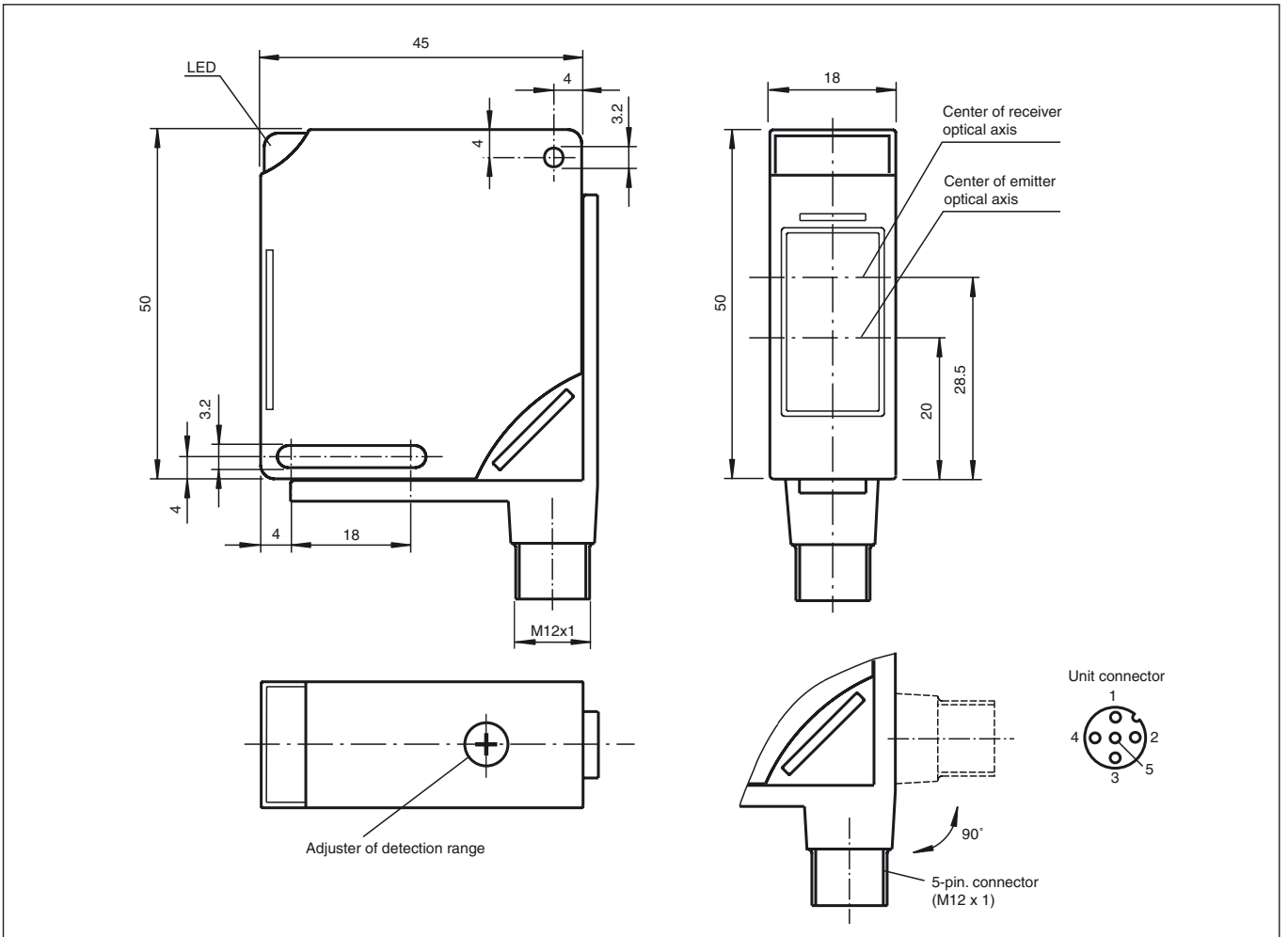

Electrical connection

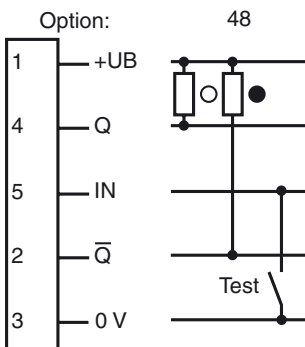

○ = light on, ● = dark on