



### Model Number

NJ20-40-N

### Features

- Comfort series
- 20 mm not embeddable

### Connection

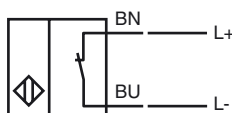

### Accessories

#### BF 40

Mounting flange, 40 mm

### Dimensions

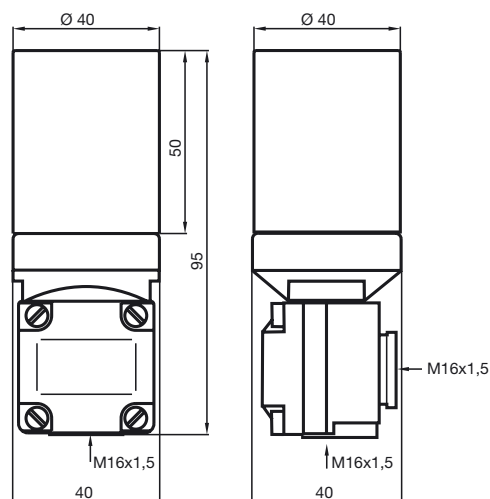

### Technical Data

#### General specifications

Switching element function	NAMUR, NC
Rated operating distance	$s_n$ 20 mm
Installation	not embeddable
Output polarity	NAMUR
Assured operating distance	$s_a$ 0 ... 16.2 mm
Reduction factor $r_{A1}$	0.4
Reduction factor $r_{Cu}$	0.3
Reduction factor $r_{303}$	0.85

#### Nominal ratings

Nominal voltage	$U_o$	8.2 V ( $R_i$ approx. 1 k $\Omega$ )
Switching frequency	$f$	0 ... 100 Hz
Current consumption		
Measuring plate not detected		$\geq 3$ mA
Measuring plate detected		$\leq 1$ mA

#### Ambient conditions

Ambient temperature	-25 ... 100 °C (-13 ... 212 °F)
---------------------	---------------------------------

#### Mechanical specifications

Connection type	terminal compartment
Core cross-section	up to 2.5 mm <sup>2</sup>
Housing material	PBT
Sensing face	PBT
Protection degree	IP67

#### General information

Use in the hazardous area	see instruction manuals
Category	2G

#### Compliance with standards and directives

Standard conformity	
NAMUR	EN 60947-5-6:2000 IEC 60947-5-6:1999
Standards	EN 60947-5-2:2007 IEC 60947-5-2:2007

#### Approvals and certificates

FM approval	
Control drawing	116-0165F
UL approval	cULus Listed, General Purpose
CSA approval	cCSAus Listed, General Purpose
CCC approval	Products with a maximum operating voltage of $\leq 36$ V do not bear a CCC marking because they do not require approval.

**ATEX 2G**

Instruction

**Device category 2G**

Directive conformity

Standard conformity

CE symbol

Ex-identification

EC-Type Examination Certificate

Appropriate type

Effective internal capacitance  $C_i$ Effective internal inductance  $L_i$ 

General

Highest permissible ambient temperature

Installation, Commissioning

Maintenance

**Special conditions**

Protection from mechanical danger

**Manual electrical apparatus for hazardous areas**

for use in hazardous areas with gas, vapour and mist

94/9/EG

EN 60079-0:2006, EN 60079-11:2007

Ignition protection "Intrinsic safety"

Use is restricted to the following stated conditions

 0102

 II 2G Ex ia IIC T6

PTB 00 ATEX 2048 X

NJ 20-40-N...

 $\leq 140$  nF ; a cable length of 10 m is considered. $\leq 140$   $\mu$ H ; a cable length of 10 m is considered.

The apparatus has to be operated according to the appropriate data in the data sheet and in this instruction manual. The EC-Type Examination Certificate has to be observed. The special conditions must be adhered to!

Directive 94/9/EG and hence also EC-Type Examination Certificates apply in general only to the use of electrical apparatus under atmospheric conditions.

The use in ambient temperatures of  $> 60$  °C was tested with regard to hot surfaces by the mentioned certification authority.

If the equipment is not used under atmospheric conditions, a reduction of the permissible minimum ignition energies may have to be taken into consideration.

The temperature ranges, according to temperature class, are given in the EC-Type Examination Certificate.

Laws and/or regulations and standards governing the use or intended usage goal must be observed. The intrinsic safety is only assured in connection with an appropriate related apparatus and according to the proof of intrinsic safety.

No changes can be made to apparatus, which are operated in hazardous areas.

Repairs to these apparatus are not possible.

When used in the temperature range below  $-20$  °C the sensor should be protected from knocks by the provision of an additional housing.