



- 1-channel
- Input frequency 1 mHz ... 12 kHz
- Analogue output 0/4 mA ... 20 mA
- Measuring range parameterisable
- 2 relay outputs
- 1 electronic output, isolated
- Each output can be assigned individual parameters, such as a trip value (high/low alarm), serially switched output, pulse divider or error message output
- Startup override
- Restart inhibit
- Bounce filter
- Parameterization via PC

48 V AC ... 253 V AC/20 V DC ... 90 V DC
KFU8-UFC-1

(without control panel)

Function

The universal frequency converter KFU8-UFC-1 converts an input frequency into a frequency-proportional current and offers at the same time the possibility to monitor trip values.

The frequency value for the minimum (0 mA or 4 mA) and the maximum output current (20 mA) is freely parameterisable.

Also the functions of the switch outputs (2 relay outputs and 1 potential free transistor output) are freely adjustable [trip value display (MIN/MAX alarm), serially switched output, pulse divider output, error signal output].

A start-up override that can be activated externally is integrated as well. The maximum input frequency is 12 kHz.

The input and output circuits are galvanically isolated.

The universal power supply allows the operation of the KFU8-UFC-1 at various supply voltages at the same terminals, without change-over or consideration of the polarity.

The device can be adjusted by means of the software.

Connection

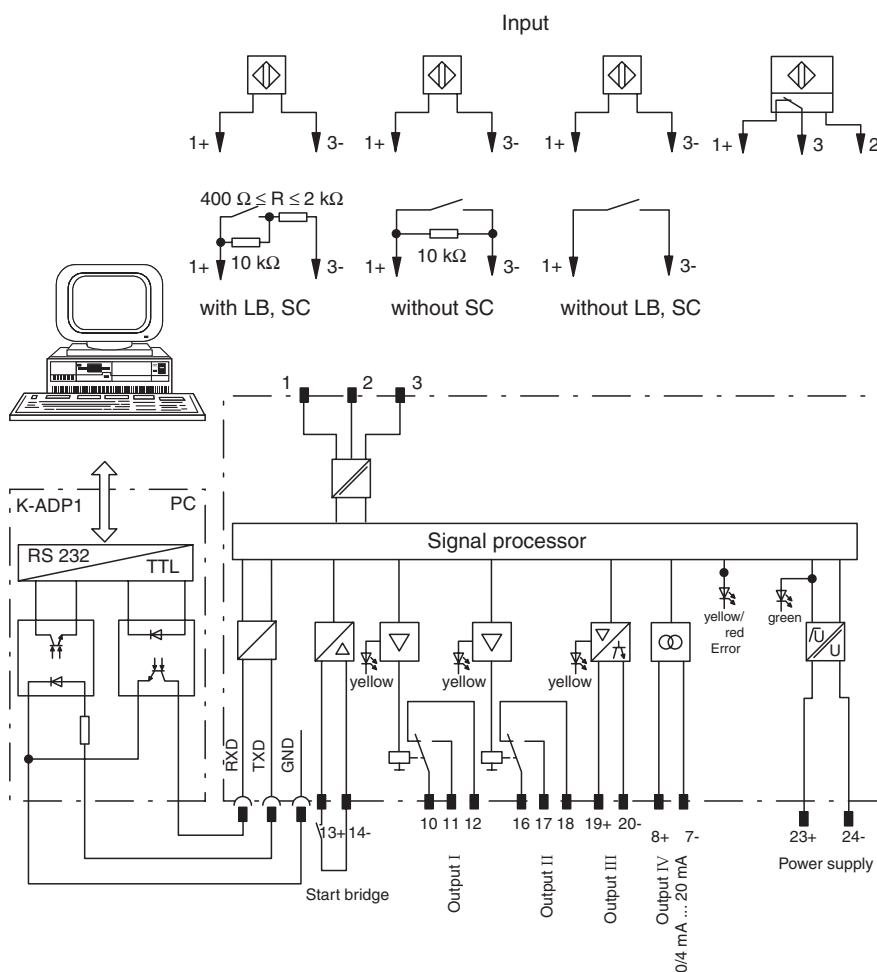

Composition

Front View

Housing type B2 (see system description)

LED yellow/red: Input pulses/ Fault signal

LED yellow: Output I-III

Programming jack

Removable terminal green

LED green: Power supply

Removable terminals green

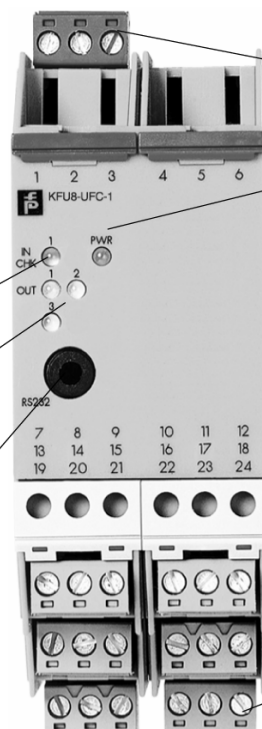

Release date 2009-07-02 11:44 Date of issue 2009-07-02 10:4656_ENG.xml

Supply	
Connection	terminals 23, 24
Rated voltage	20 ... 90 V DC / 48 ... 253 V AC
Power loss/power consumption	≤ 2 W ; 2.5 VA / 2.2 W ; 3 VA
Input	
Connection	input I: 2-wire sensor: terminals 1+, 3- three wire sensor: terminals 1+, 2- and 3 input II: terminals 13+, 14- startup override;
Input I	
Open circuit voltage/short-circuit current	22 V / 40 mA
Input resistance	4.7 kΩ
Switching point/switching hysteresis	logic 1: > 2.5 mA ; logic 0: < 1.9 mA
Pulse duration	> 50 μs
Input frequency	0.001 ... 12000 Hz
Lead monitoring	breakage I ≤ 0.15 mA; short-circuit I > 4 mA
Input II	
Active/passive	I > 4 mA (for min. 100 ms) / I < 1.5 mA
Open circuit voltage/short-circuit current	18 V / 5 mA
Output	
Connection	output I: terminals 10, 11, 12 ; output II: terminals 16, 17, 18 output III: terminals 19+, 20- ; output IV: terminals 8+, 7-
Output I, II	
Contact loading	250 V AC / 2 A / cos φ ≥ 0.7 ; 40 V DC / 2 A
Mechanical life	5 x 10 ⁷ switching cycles
Energized/de-energized delay	approx. 20 ms / approx. 20 ms
Output III	
Signal level	1-signal: (L+) -2.5 V (50 mA, short-circuit/overload proof) 0-signal: blocked output (off-state current ≤ 10 μA)
Output IV	
Current range	0 ... 20 mA or 4 ... 20 mA
Open circuit voltage	≤ 24 V DC
Load	≤ 650 Ohm
Fault signal	downscale I ≤ 3.6 mA , upscale ≥ 21.5 mA (acc. NAMUR NE43)
Transfer characteristics	
Input I	
Measuring range	0.001 ... 12000 Hz
Resolution	0.1 % of the measurement value , ≥ 0.001 Hz
Accuracy	0.1 % of the measurement value , > 0.001 Hz
Measuring time	< 100 ms
Influence of ambient temperature	0.003 %/°C (30 ppm)
Output I, II	
Response delay	≤ 200 ms
Output IV	
Resolution	≤ 10 μA
Accuracy	< 20 μA
Influence of ambient temperature	0.005 %/°C (50 ppm)
Electrical isolation	
Input/other circuits	safe electrical isolation acc. to EN 50020, voltage peak value 375 V
Output I, II/other circuits	reinforced insulation acc. to IEC 61140, rated insulation voltage 300 V _{rms}
Mutual output I, II, III	reinforced insulation acc. to IEC 61140, rated insulation voltage 300 V _{rms}
Output III, IV/power supply	reinforced insulation acc. to IEC 61140, rated insulation voltage 300 V _{rms}
Output III/IV/start-up override	functional insulation acc. to EN 50178, rated insulation voltage 253 V _{eff}
Start-up override/power supply	reinforced insulation acc. to IEC 61140, rated insulation voltage 300 V _{rms}
Interface/power supply	reinforced insulation acc. to IEC 61140, rated insulation voltage 300 V _{rms}
Interface/output III	functional insulation acc. to DIN EN 50178, rated insulation voltage 300 V _{rms}
Directive conformity	
Electromagnetic compatibility	
Directive 89/336/EEC	EN 50081-2, EN 50082-2
Conformity	
Insulation coordination	EN 50178
Electrical isolation	EN 50178
Protection degree	IEC 60529
Input	EN 60947-5-6
Ambient conditions	

Release date 2009-07-02 11:44 Date of issue 2009-07-02 104656_ENG.xml

Ambient temperature	-20 ... 60 °C (253 ... 333 K)
Mechanical specifications	
Protection degree	IP20
Mass	300 g
Dimensions	40 x 100 x 115 mm (1.6 x 3.9 x 4.5 in)

Supplementary information

Statement of Conformity, Declaration of Conformity and instructions have to be observed. For information see www.pepperl-fuchs.com.

Accessories

PACT^{ware}™

Device-specific drivers (DTM)

Adapter K-ADP1

Programming adapter for parameterisation via the serial RS 232 interface of a PC/Notebook

For programming, please use the new version of adapter K-ADP1 (part no. 181953, connector length 14mm). When using the previous version K-ADP1 (connector length 18 mm) the plug is exposed by approx. 3 mm. The function is not affected.

Adapter K-ADP-USB

Programming adapter for parameterisation via the serial USB interface of a PC/Notebook