

Dimensions

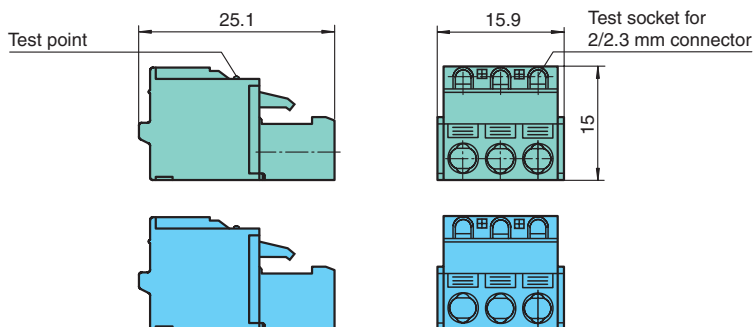

Features

- 3-pin
- For KF modules
- Integrated test points for connection of HART communicators
- Connection safe area (green)
- Connection hazardous area (blue)
- Packaging unit: 3 pieces, green and 2 pieces, blue

Function

The KF modules can be converted to have screwless cage spring terminals KF-FKC-**. It has integrated test points for connection of HART communicators.

Technical data

Mechanical specifications

Dimensions	15.9 x 15 x 25.1 mm (0.63 x 0.6 x 1 in)
Construction type	Cage clamp terminals with integrated test points

Notes

The removable terminals guarantee protection from direct contact by means of a strengthened insulation. This applies to design insulation voltages with the occurrence of maximum overvoltages in accordance with overvoltage category III of EN 50178 (1500 V AC).

The voltage is to be switched off in the case of design insulation voltages greater than 50 V AC before connecting or disconnecting the device connectors.