



### Model Number

#### ORR50G

Reflector, rectangular 50.9 mm x 60.9 mm, mounting holes, fixing strap and polarization filter

### Features

- Active reflector field 44 mm x 44 mm
- Especially for the detection of foils and transparent objects with varying of polarisation properties in conjunction with sensors to detect clear glass
- Mounting holes for simple installation
- With surface mounted polarization filter

For use with retroreflective sensors for glass/foil detection in red light

### Dimensions

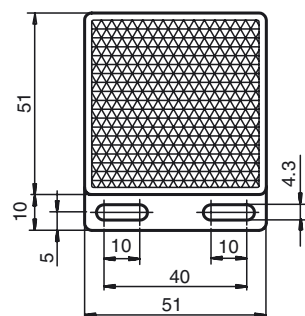

T = 8

### Technical data

#### General specifications

Construction type rectangular

#### Ambient conditions

Ambient temperature 0 ... 50 °C (32 ... 122 °F)

#### Mechanical specifications

Material PMMA/ABS

Dimensions 51 mm x 61 mm x 8 mm

Mounting mounting holes

### Note

The additional light attenuation due to the polarisation filter reduces the nominal range on sensors by approx. 25% compared with operation with the standard reflector.

### Mounting

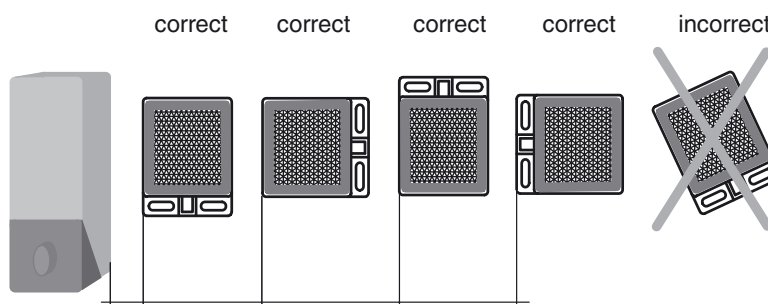

The edge of the sensor must be parallel with the edge of the reflector !

Many transparent films with polarisation-modifying characteristics cannot be detected, or can only be detected with difficulty, when standard reflectors are used in association with sensors for clear glass detection. This problem is solved by using this reflector.

#### Operation instructions:

- When aligning the system, the sensor Teach-in function should be used. In rare cases, however, manual adjustment of the sensitivity via the sensor keypad may be necessary. This applies, for example, to CD cases, on which the signal attenuation near to the edges is much stronger than in the centre. A Teach-in operation would match the response threshold at the strongly attenuated edge region. The detection of the poorly absorbing centre area of the CD case would then become questionable. In such cases a solution is found by manually adjusting the sensitivity.
- For a sure detection of films with extremely inhomogeneous polarisation characteristics, the reflector must be mounted as close as possible to the film.

#### Notes on use and cleaning:

- Not suitable for regular outside use or in wet / damp areas.
- Clean with a damp cloth or with methylated spirits. Do not use aggressive or scouring cleaning agents.