



Model Number

RL39-54/32/40a/82a/116

Retroreflective sensor
with terminal compartment

Features

- Glare protected with polarization filter
- Visible red light
- Light/dark ON, switchable
- Protection degree IP67

Dimensions

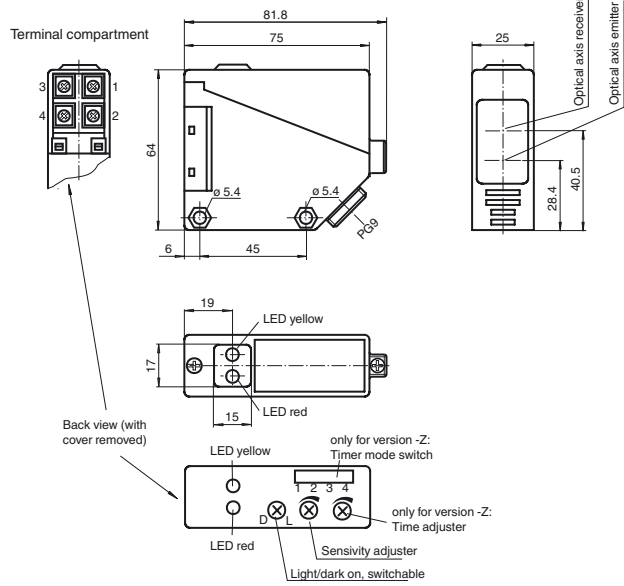

Electrical connection

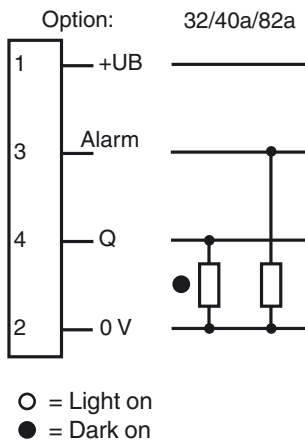

Release date: 2011-10-17 08:42 Date of issue: 2011-10-17 088820_eng.xml

Subject to modifications without notice

Pepperl+Fuchs Group
www.pepperl-fuchs.com

USA: +1 330 486 0001
fa-info@us.pepperl-fuchs.com

Germany: +49 621 776-4411
fa-info@pepperl-fuchs.com

Copyright Pepperl+Fuchs
Singapore: +65 6779 9091
fa-info@sg.pepperl-fuchs.com

Technical data**General specifications**

Effective detection range	0 ... 7 m
Reflector distance	100 ... 9000 mm
Threshold detection range	9 m
Reference target	H85 reflector
Light source	LED
Light type	modulated visible red light
Approvals	CE
Ambient light limit	10000 Lux

Indicators/operating means

Function display	LED yellow: switching state LED red: pre-fault indication
Controls	sensitivity adjustment
Controls	Light/Dark switch

Electrical specifications

Operating voltage	U_B	10 ... 30 V DC
Ripple		10 %
No-load supply current	I_0	≤ 35 mA
Time delay before availability	t_v	≤ 50 ms

Output

Output of the pre-fault indication	1 PNP, active when falling short of the stability control	
Switching type	light/dark on	
Signal output	1 PNP output, short-circuit protected, protected from reverse polarity, open collector	
Switching voltage	max. 30 V DC	
Switching current	max. 200 mA	
Voltage drop	U_d	≤ 3 V
Switching frequency	f	≤ 300 Hz
Response time		≤ 1.5 ms

Standard conformity

Standards	EN 60947-5-2
-----------	--------------

Ambient conditions

Ambient temperature	-25 ... 55 °C (-13 ... 131 °F)
Storage temperature	-40 ... 55 °C (-40 ... 131 °F)

Mechanical specifications

Protection degree	IP67
Connection	terminal compartment PG9, ≤ 2.5 mm ²
Material	
Housing	PBT
Optical face	PMMA
Mass	100 g

Approvals and certificates

CCC approval	Products with a maximum operating voltage of ≤ 36 V do not bear a CCC marking because they do not require approval.
--------------	--

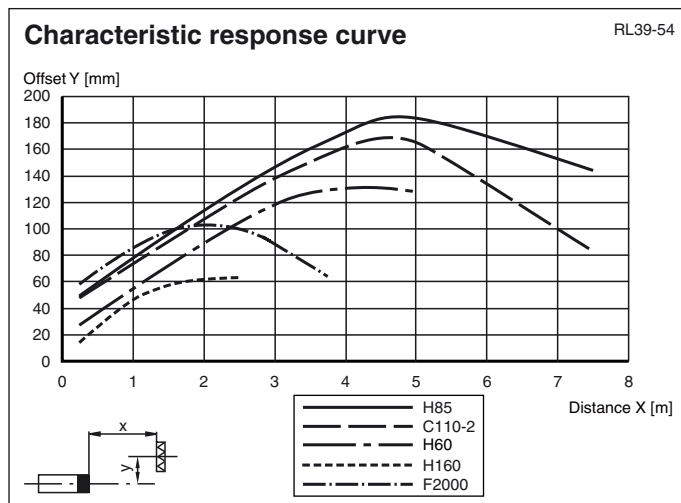
Curves/Diagrams

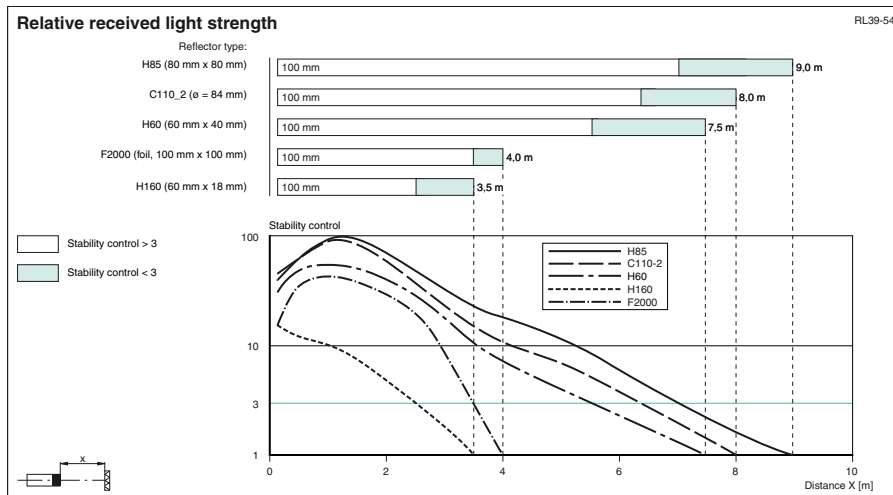

Additional Information

Conventional use:

The reflex light beam switch contains the emitter and receiver in a single housing. The light from transmitter is beamed back from a reflector to the receiver. If an object interrupts the light beam the switching function is initiated.

Mounting instructions:

The sensor can be fastened over the through-holes directly or with the included mounting bracket.

The base surface must be flat to avoid distorting the housing during mounting. It is advisable to secure the bolts and screws with washers to prevent misalignment of the sensor.

Instructions for adjustment:

Connect the sensor to operating voltage, the LED green lights up constantly.

Mount suitable reflector opposite light beam switch and align roughly.

The exact adjustment takes by swivelling the sensor horizontally and vertically. With optimum light reception the yellow LED lights up constantly. In case of bad alignment, the red LED lights up.

Object detection check:

Move the object into the light beam. If the object is recorded, the yellow LED goes off. If it isn't going off, reduce the sensitivity with the potentiometer until it goes off. It should light up constantly again when the object is removed.

The red LED lights up if reception deteriorates (e.g. soiled lenses or by maladjustment) and when falling short of the stability control.

Illustration:

We recommend that you clean the optical interfaces and check the plug-in connections and screw connections at regular intervals.