



Model Number

NBN30+U9A+B3

Features

- Basic series
- 30 mm non-flush
- NO/NC programmable
- Adjustable sensor head
- Oscillator monitoring

Connection

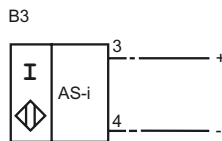

Dimensions

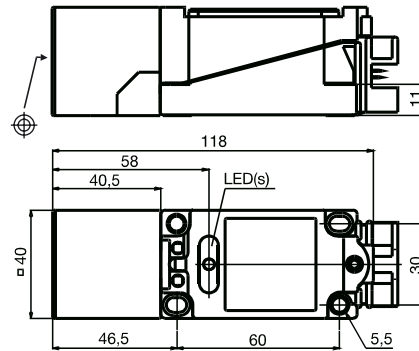

Technical Data

General specifications

Switching element function		NO/NC programmable
Rated operating distance	s_n	30 mm
Installation		non-flush
Output polarity		AS-Interface
Assured operating distance	s_a	0 ... 24.3 mm
Reduction factor r_{AI}		0.5
Reduction factor r_{Cu}		0.45
Reduction factor r_{304}		0.85

Nominal ratings

Operating voltage	U_B	26.5 ... 31.9 V via AS-i bus system
Switching frequency	f	0 ... 150 Hz
Hysteresis	H	1 ... 15 typ. 5 %
Reverse polarity protected		reverse polarity protected
No-load supply current	I_0	≤ 25 mA
Operating voltage display		LED, green
Indication of the switching state		LED, yellow

Standard conformity

Standards	IEC / EN 60947-5-2:2004
-----------	-------------------------

Ambient conditions

Ambient temperature	-25 ... 70 °C (-13 ... 158 °F)
Storage temperature	-40 ... 85 °C (-40 ... 185 °F)

Mechanical specifications

Core cross-section	AS-Interface flat cable
Housing material	PBT
Sensing face	PBT
Protection degree	IP67

Programming Instructions

Address 00 preset, alterable
via Busmaster or
programming units
IO-Code 1
ID-Code 1

Data bit

Bit Function

D0 switching state¹⁾
(0 = damped; 1 = undamped)
D1 not used
D2 oscillator monitoring
(0= oscillator defective,
1=normal operation)
D3 not used

Parameter bit

Bit Function

P0 not used
P1 switching element function²⁾
(0 = NC; 1 = NO)
P2 not used
P3 not used

¹⁾ Applies to NO funktion (P1 = 1; preset),
with NC funktion (P1 = 0) reversed characteristics
²⁾ Default setting: NO