



OBS1500-18GM70-E5

Reflection light beam switch

OBS1500-18GM70-E5

with 2 m fixed cable

CE



- ◆ Detection range up to 1500 mm
- ◆ Light/dark ON, programmable
- ◆ Visible red light
- ◆ Glare protected with polarisation filter
- ◆ Protection degree IP67
- ◆ Strong metallic housing in cylindrical shape M18 x 1
- ◆ Sensitivity adjuster for optimal adaptation to the application
- ◆ LED indicator for a simple operation start

Release date: 2004-07-20 09:39 Date of issue: 2005-07-06 08:4802_ENG.xml

General specifications

Effective detection range	0 ... 1500 mm
Reflector distance	100 ... 1500 mm
Light source	LED
Approvals	CE
Reference target	reflector C110_2
Light type	red, modulated light
Ambient light limit	10000 Lux

Indicators/operating means

Function display	LED yellow: switching state
Operating elements	sensitivity adjuster

Electrical specifications

Operating voltage	10 ... 30 V DC
Ripple	10 %
No-load supply current I_0	≤ 20 mA
Time delay before availability t_v	≤ 50 ms

Output

Switching type	light/dark switching
Signal output	1 switch output pnp
Switching voltage	max. 30 V DC
Switching current	max. 100 mA
Voltage drop U_d	≤ 2.5 V
Switching frequency f	≤ 300 Hz
Switch-on delay t_{on}	1.5 ms
Response time	≤ 1.5 ms

Standard conformity

Standards	EN 60947-5-2
-----------	--------------

Ambient conditions

Ambient temperature	-25 ... 55 °C (248 ... 328 K)
Storage temperature	-40 ... 70 °C (233 ... 343 K)

Mechanical specifications

Protection degree	IP67
Connection	2 m cable, 3 x 0,34 mm ² , PVC
Material	
Housing	brass, nickel-plated
Optical face	PMMA
Mass	45 g

Release date: 2004-07-20 09:39 Date of issue: 2005-07-06 084802_ENG.xml



OBS1500-18GM70-E5

Curves/Diagrams

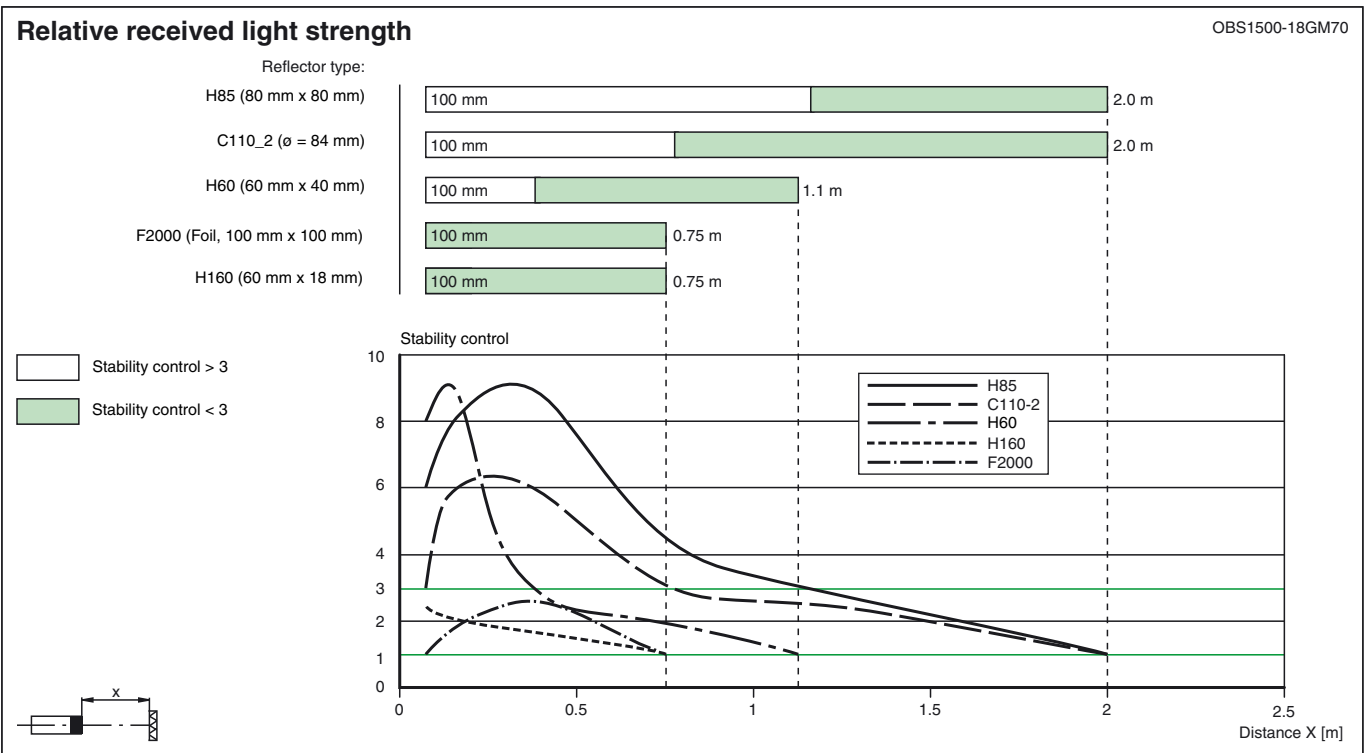
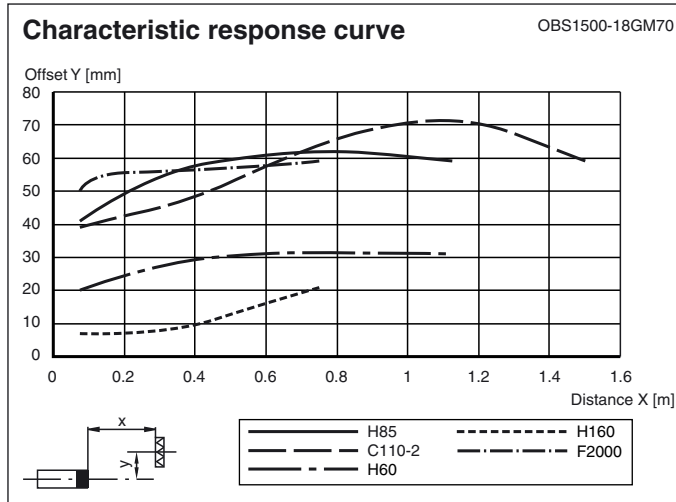

Release date: 2004-07-20 09:39 Date of issue: 2005-07-06 08:4802_ENG.xml

Dimensions

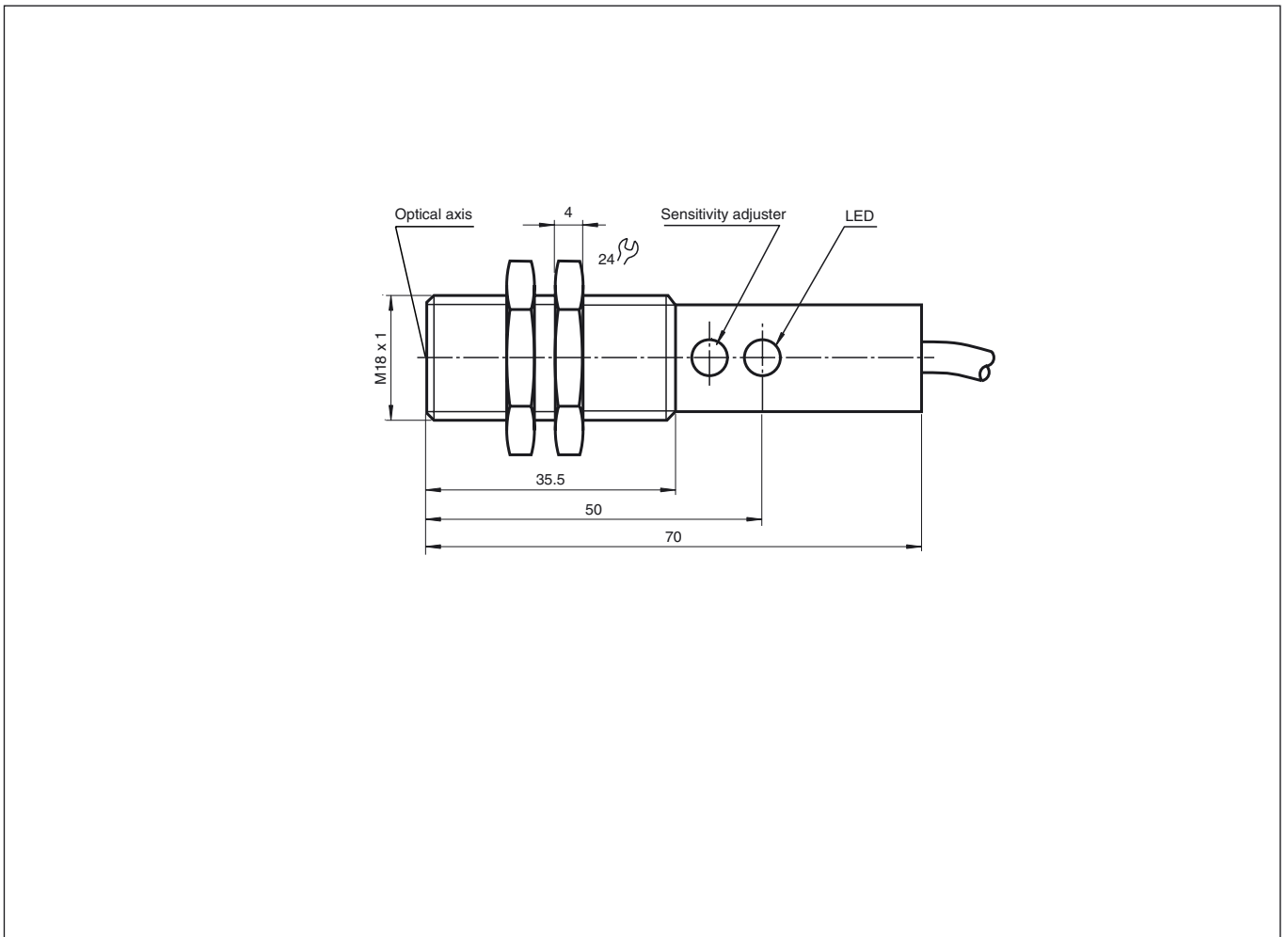

Electrical connection

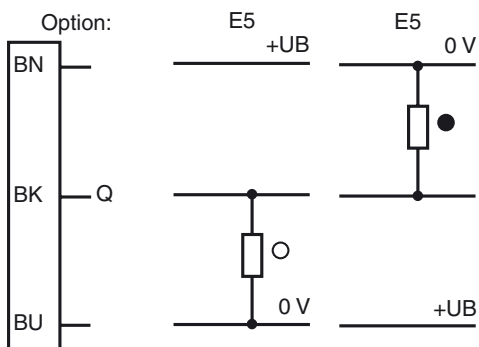

○ = light on, ● = dark on