



OBS3000-18GM70-E5-V1

Reflection light beam switch

# OBS3000-18GM70-E5-V1

with 4-pin, M12 connector

CE



- ◆ Detection range up to 3000 mm
- ◆ Light/dark ON, programmable
- ◆ Protection degree IP67
- ◆ Strong metallic housing in cylindrical shape M18 x 1
- ◆ Sensitivity adjuster for optimal adaptation to the application
- ◆ LED indicator for a simple operation start

Release date: 2004-07-20 09:39 Date of issue: 2005-07-06 08:407\_ENG.xml

**General specifications**

Effective detection range	0 ... 3 m
Reflector distance	100 ... 3000 mm
Light source	LED
Approvals	CE
Reference target	reflector C110_2
Light type	infrared, modulated light
Ambient light limit	10000 Lux

**Indicators/operating means**

Function display	LED yellow: switching state
Operating elements	sensitivity adjuster

**Electrical specifications**

Operating voltage	10 ... 30 V DC
Ripple	10 %
No-load supply current $I_0$	$\leq 20$ mA
Time delay before availability $t_v$	$\leq 50$ ms

**Output**

Switching type	light/dark switching
Signal output	1 switch output pnp
Switching voltage	max. 30 V DC
Switching current	max. 100 mA
Voltage drop $U_d$	$\leq 2.5$ V
Switching frequency $f$	$\leq 300$ Hz
Switch-on delay $t_{on}$	1.5 ms
Response time	$\leq 1.5$ ms

**Standard conformity**

Standards	EN 60947-5-2
-----------	--------------

**Ambient conditions**

Ambient temperature	-25 ... 55 °C (248 ... 328 K)
Storage temperature	-40 ... 70 °C (233 ... 343 K)

**Mechanical specifications**

Protection degree	IP67
Connection	connector M12 x 1, 4-pin
Material	
Housing	brass, nickel-plated
Optical face	PC
Mass	45 g

Release date: 2004-07-20 09:39 Date of issue: 2005-07-06 082407\_ENG.xml



# OBS3000-18GM70-E5-V1

## Curves/Diagrams

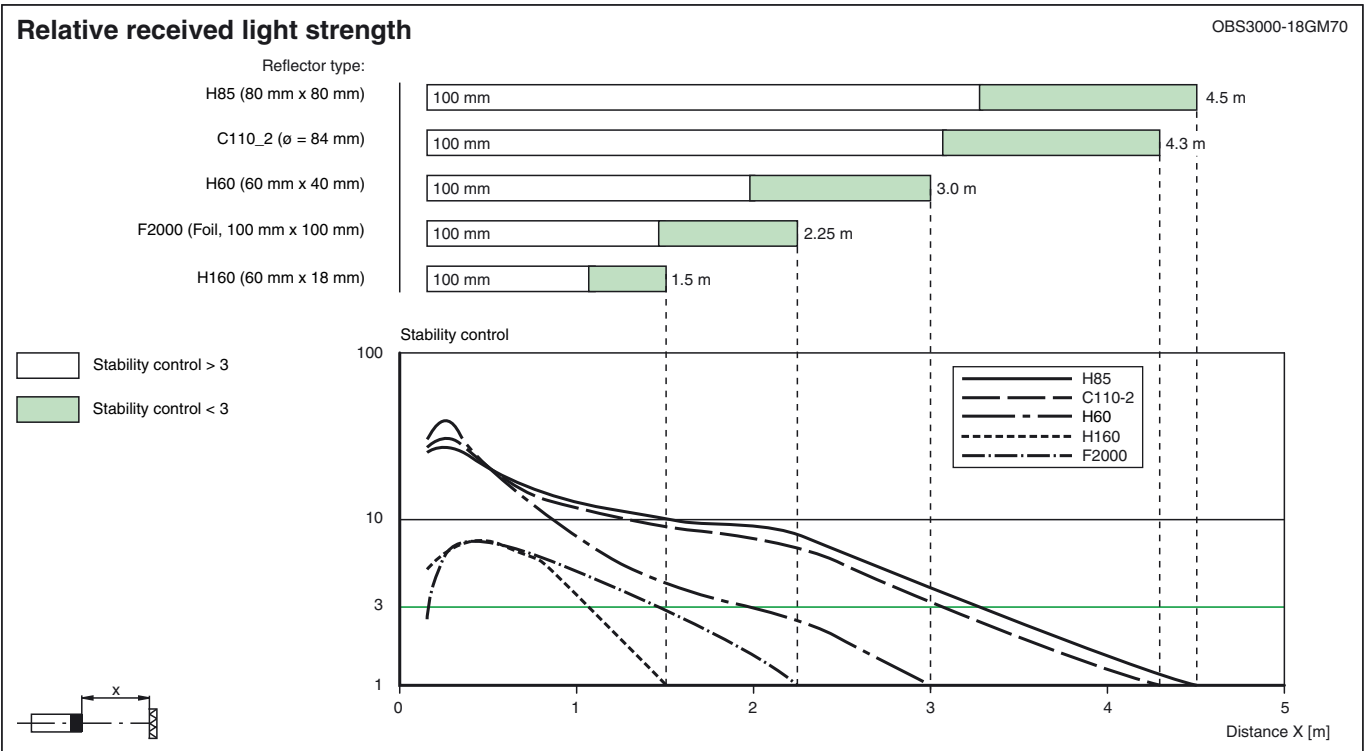
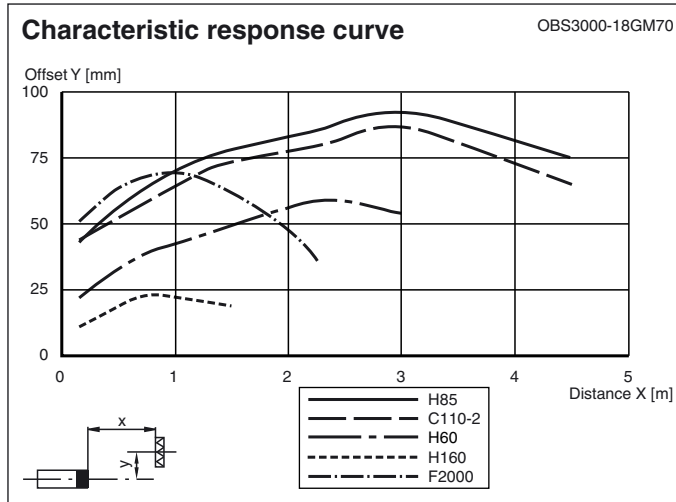

Release date: 2004-07-20 09:39 Date of issue: 2005-07-06 082407\_ENG.xml

Dimensions

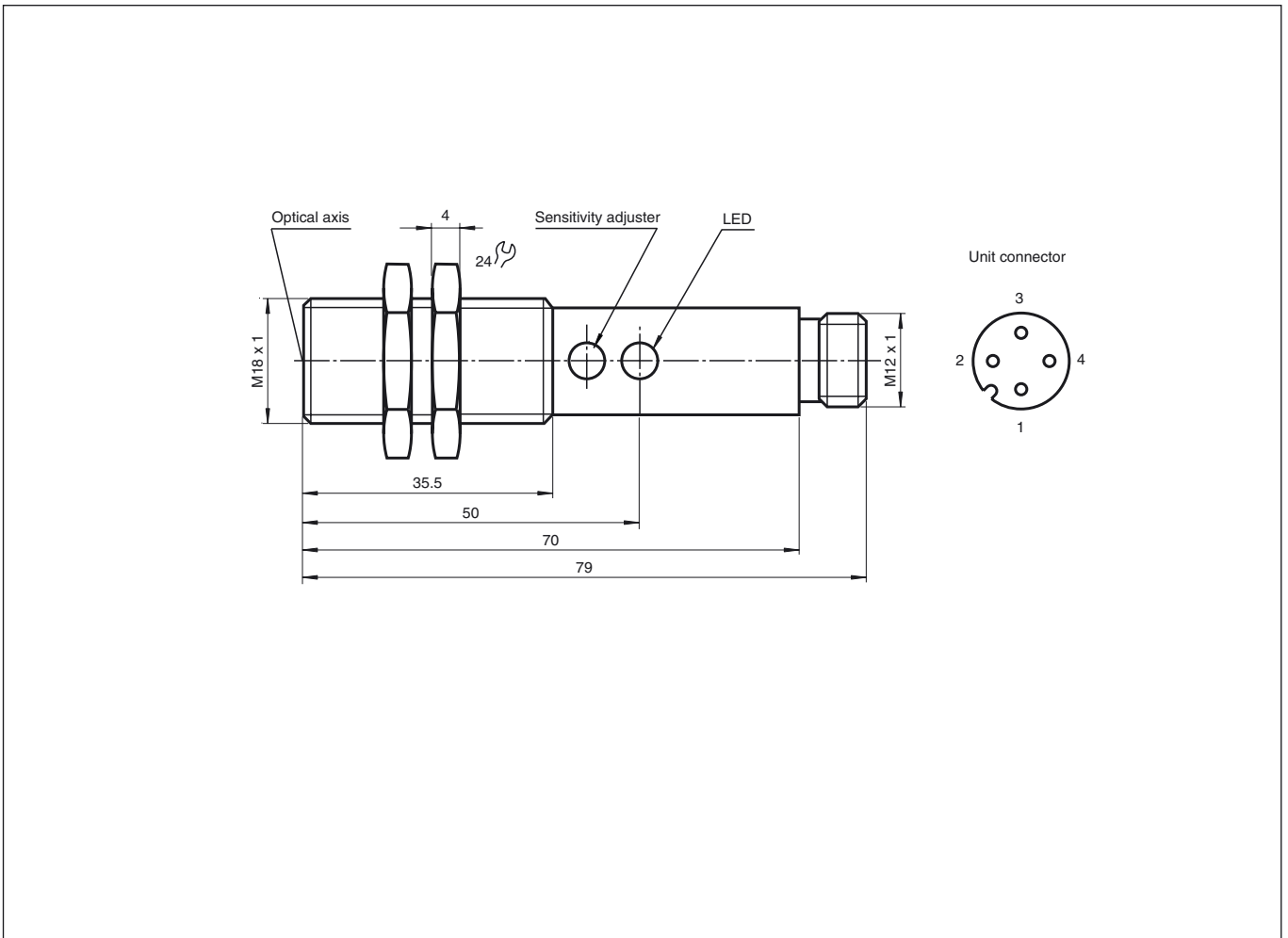

Electrical connection

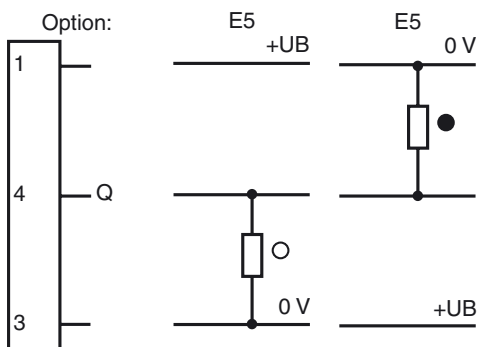

○ = light on, ● = dark on

Release date: 2004-07-20 09:39 Date of issue: 2005-07-06 082407\_ENG.xml