

Dimensions

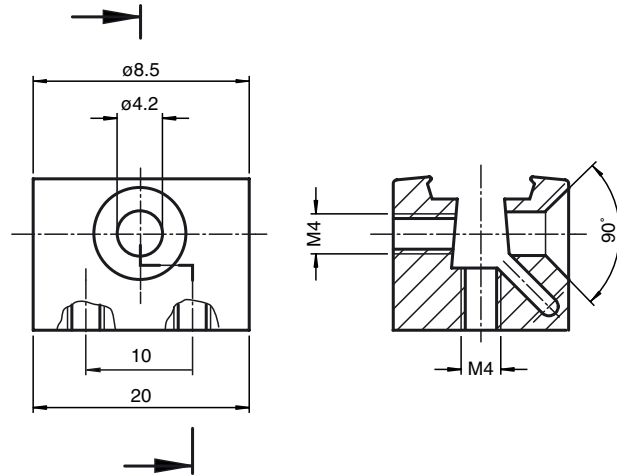

Model number

OMH-MLV11-K

Fixation clamp for sensors with dove tail

Features

- Fixation clamp
- Simple and fast mounting

Technical data

Mechanical specifications

Material	aluminium
Mass	approx. 8 g

suitable series

Series	MLV11 MLV12 RL28 RL29
Safety Series	SL12, SLA12 , SLA28 , SL29, SLA29