



**Model Number**

PL1-F25-E8-S

**Features**

- For installation in housing
- PL1... with valve connection
- Valve LEDs disconnectable (wire jumper)
- Satisfies machinery directive

**Connection**

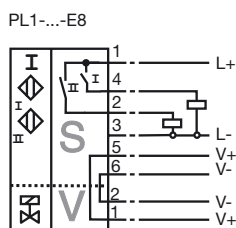

**Accessories**

- BT32**  
Activator for F25 series
- BT32XS**  
Activator for F25 series
- BT32XAS**  
Activator for F25 series
- BT33**  
Activator for F25 series
- BT34**  
Activator for F25 series

**Dimensions**

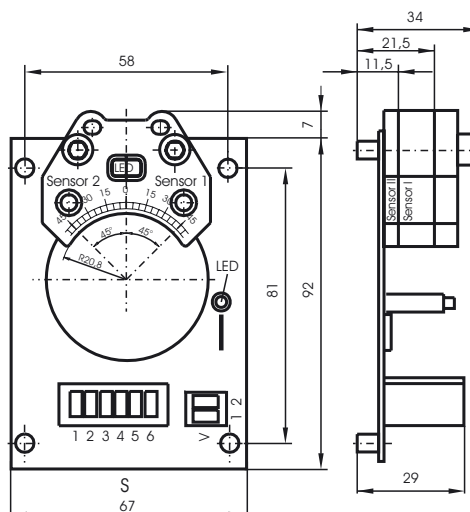

**Technical Data**

General specifications		
Switching element function	PNP	Dual NO
Rated operating distance	$s_n$	3 mm
Installation		embeddable mountable
Output polarity		DC
Assured operating distance	$s_a$	0 ... 2.43 mm
Reduction factor $r_{AI}$		0.5
Reduction factor $r_{304}$		1
Reduction factor $r_{Si37}$		1.1
Nominal ratings		
Operating voltage	$U_B$	10 ... 30 V DC
Switching frequency	$f$	0 ... 100 Hz
Hysteresis	$H$	typ. 5 %
Reverse polarity protected		reverse polarity protected
Short-circuit protection		pulsing
Voltage drop	$U_d$	$\leq 3$ V
Operating current	$I_L$	0 ... 200 mA
Off-state current	$I_r$	0 ... 0.5 mA typ. 0.1 $\mu$ A at 25 °C
No-load supply current	$I_0$	$\leq 25$ mA
Operating voltage display		LED, green
Indication of the switching state		LED, yellow
Valve status indication		LED, yellow
Ambient conditions		
Ambient temperature		-25 ... 70 °C (-13 ... 158 °F)
Storage temperature		-40 ... 85 °C (-40 ... 185 °F)
Mechanical specifications		
Core cross-section (system side)		up to 2.5 mm <sup>2</sup>
Core cross-section (valve side)		up to 2.5 mm <sup>2</sup>
Housing material		PBT
Sensing face		PBT
Protection degree		IP20
Note		Installation in housing
Compliance with standards and directives		
Standard conformity		
Standards		EN 60947-5-2:2007 IEC 60947-5-2:2007

Release date: 2011-07-28 14:50 Date of issue: 2012-02-03 044565\_eng.xml

**Type code: PL1-F25-E8-S**

**Circuit board** **PL1-F25-E8-S**

PL1 With 1 valve connection and LED

**Sensor type** **PL1-F25-E8-S**

F25 F25 proximity switch standard series

**Electrical type** **PL1-F25-E8-S**

E8 3-wire DC

**Connection technology** **PL1-F25-E8-S**

S Removable screw terminal

Release date: 2011-07-28 14:50 Date of issue: 2012-02-03 044565\_eng.xml