

Ultrasonic sensor UB6000-FP-H3

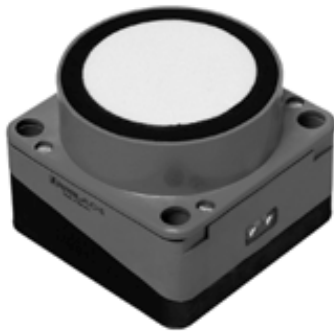

Features

- Separate evaluation
- With temperature sensor
- Direct detection mode

Electrical connection

Standard symbol/Connection:

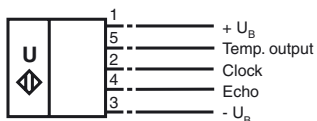

Dimensions

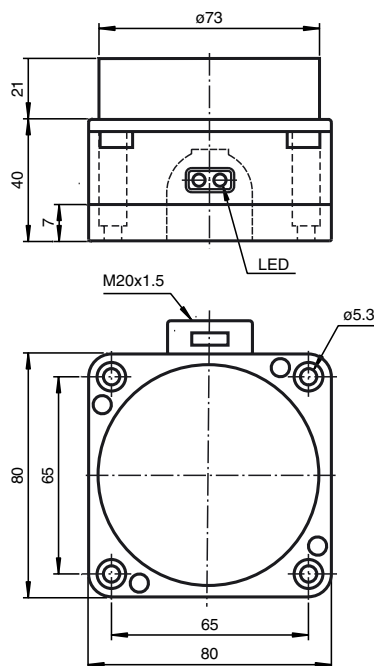

Technical data



General specifications

Sensing range	800 ... 6000 mm
Unusable area	0 ... 800 mm ¹⁾
Standard target plate	100 mm x 100 mm
Transducer frequency	approx. 65 kHz

Electrical specifications

Operating voltage	20 ... 30 V DC, ripple 10 % _{SS}
No-load supply current I ₀	≤ 30 mA

Input

Input type	1 pulse input for transmitter pulse, activation through open collector npn < 1 V: emitter active, > 4 V: emitter inactive
Pulse length	50 ... 700 μs (typ. 500 μs) ²⁾
Pause length	≥ 50 x pulse length

Output

Output type	1 pulse output for temperature 1-level: > 4 V (100 μA), 0-level: < 0.5 V (100 μA) 1 pulse output for echo propagation time 1-level: ≥ U _B - 3 V (< 10 mA), 0-level: ≤ 1 V (100 μA) 10 μs/K + timer pulse, synchronisation with the timer pulse the echo propagation time: ≤ 0.17 % / K
Pulse length	
Temperature influence	

Standard conformity

Standards	EN 60947-5-2
-----------	--------------

Ambient conditions

Ambient temperature	-25 ... 70 °C (248 ... 343 K)
Storage temperature	-40 ... 85 °C (233 ... 358 K)

Mechanical specifications

Protection degree	IP65
Connection	terminal compartment, ≤ 2.5 mm ² conductor csa
Material	
Housing	PBT
Transducer	epoxy resin/hollow glass sphere mixture; polyurethane foam
Mass	320 g

Notes

Description of the sensor functions

The sensing range is determined in the downstream evaluation electronics (e. g. the units UH3-KHD2-4E5, or UH3-KHD2-4I).

The sensing range is determined on the basis of the echo time of a transmitted pulse in pulse-echo mode.

Temperature compensation

A temperature pulse is available at the temperature output for external temperature compensation. It is synchronous to the externally applied clock pulse and has the length T_{Temp} , calculated as follows:

$$T_{Temp}[\mu s] = T_{Takt}[\mu s] + T[K] \times 10 \mu s / K$$

Put into the formula the temperature in Kelvin and the clock time in the unit μs .

- 1) The unusable area (blind range) BR depends on the pulse duration.
The unusable area reaches a minimum with the shortest pulse duration.
- 2) The sensors detection range depends on the pulse duration.
With pulse duration < typical pulse duration, the sensors detection range may be reduced.

Model number

UB6000-FP-H3

Characteristic curves/additional information

Characteristic response curves

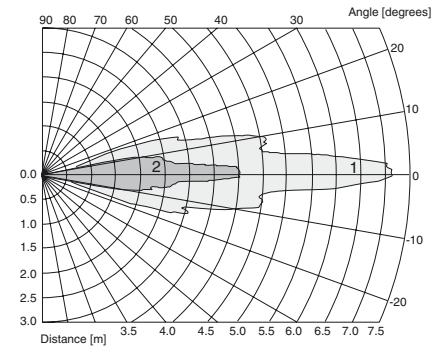

Curve 1: flat surface 100 mm x 100 mm
Curve 2: round bar, Ø 25 mm

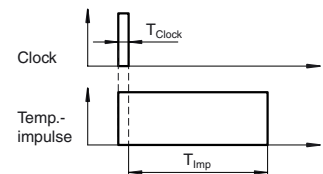

$$T_{Imp} = T [K] \times 10 \mu s / K$$
$$T_{Temp} = T_{Clock} + T_{Imp}$$

Accessories

Mounting aid

MH 04-3505
MHW11

Evaluation units

UH3-KHD2-4E5
UH3-KHD2-4I
UH3-T1-KT