



OCT500-M1A-B3-V1

Diffusive sensor

# OCT500-M1A-B3-V1

connector M12 x 1, 4-pin

CE



- ◆ Light/dark ON parameterisable
- ◆ AS-Interface certificate
- ◆ Pre-fault indication (dynamic, static)
- ◆ Protected against mutual interference
- ◆ Removable terminal compartment
- ◆ Position of the sensor head adjustable
- ◆ For glass fibre light guide

Release date: 2006-02-21 13:29 Date of issue: 2006-02-21 038094\_ENG.xml

**General specifications**

Detection range	without light guide : 0 ... 500 mm , with light guide see selection table for fibre optics
Detection range min.	0 ... 40 mm
Detection range max.	0 ... 500 mm
Light source	LED
Approvals	CE
Reference target	standard white 200 mm x 200 mm
Light type	infrared, modulated light
Ambient light limit	40000 Lux

**Indicators/operating means**

Operating display	LED green
Function display	LED yellow: switching state LED red: stability control (flashing)

**Electrical specifications**

Operating voltage	via AS-Interface network
Ripple	10 %
No-load supply current $I_0$	$\leq 40$ mA
Time delay before availability $t_v$	$\leq 20$ ms

**Output**

Output of the pre-fault indication	data bit D1 (not at 1.5 kHz)
Switching type	light/dark switching
Signal output	AS-Interface
Switching frequency $f$	$\leq 1.5$ kHz / 200 Hz switchable
Response time	$\leq 0.3$ ms at 1.5 kHz $\leq 2.5$ ms at 200 Hz
Timer function	pulse extension 20 ms, configurable

**Standard conformity**

Standards	EN 60947-5-2
-----------	--------------

**Ambient conditions**

Ambient temperature	-25 ... 70 °C (248 ... 343 K)
Storage temperature	-40 ... 80 °C (233 ... 353 K)

**Mechanical specifications**

Protection degree	IP67
Connection	connector M12 x 1, 4-pin
Material	
Housing	PBT
Optical face	Scratch resistant mineral glass lens
Mass	100 g

Release date: 2006-02-21 13:29 Date of issue: 2006-02-21 038094\_ENG.xml

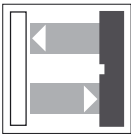

# OCT500-M1A-B3-V1

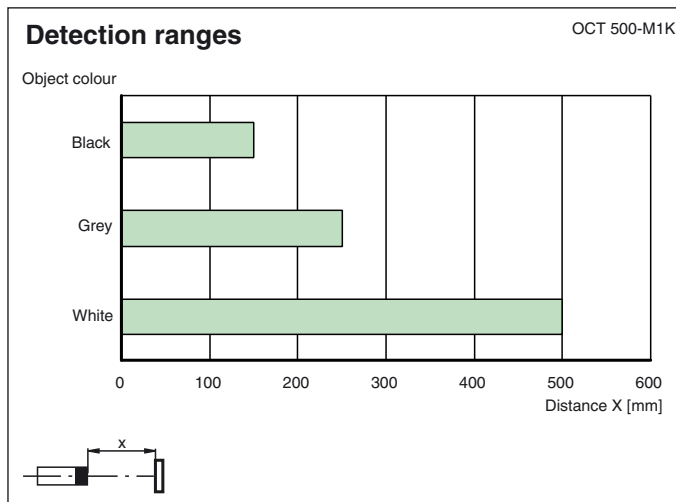
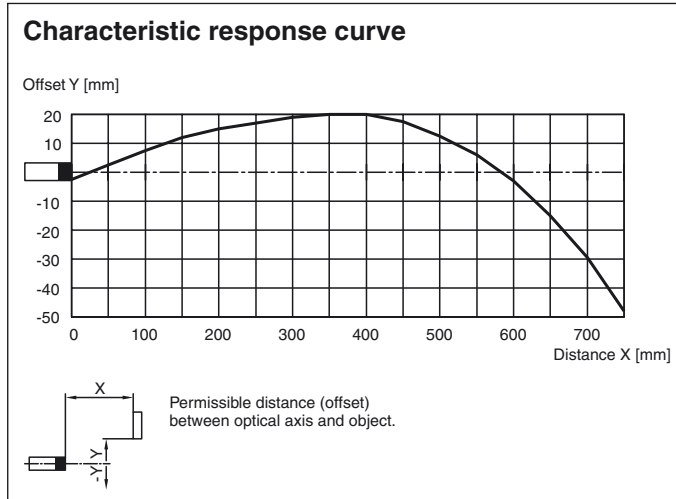

## AS-Interface programming

Address preset to 00, can be changed via Busmaster or programming devices

IO code 1

ID code 1

### • Data bit

#### Bit Function

- D0 switch output
- D1 pre-fault indication (0=ON, 1=OFF)
- D2 ready to operate
- D3 switching frequency 200 Hz\*/1.5 kHz<sup>3)</sup>

### • Parameter bit

#### Bit Function (1/2)

- P0 pulse frequency 1\*/2
- P1 switch output, light\*/dark ON
- P2 pulse extension (20 ms) OFF\*/ON
- P3 pre-fault indication<sup>3)</sup> dynamic\*/static

\* Default setting

<sup>3)</sup>No activation of pre-fault signal at 1.5 kHz.

Dimensions

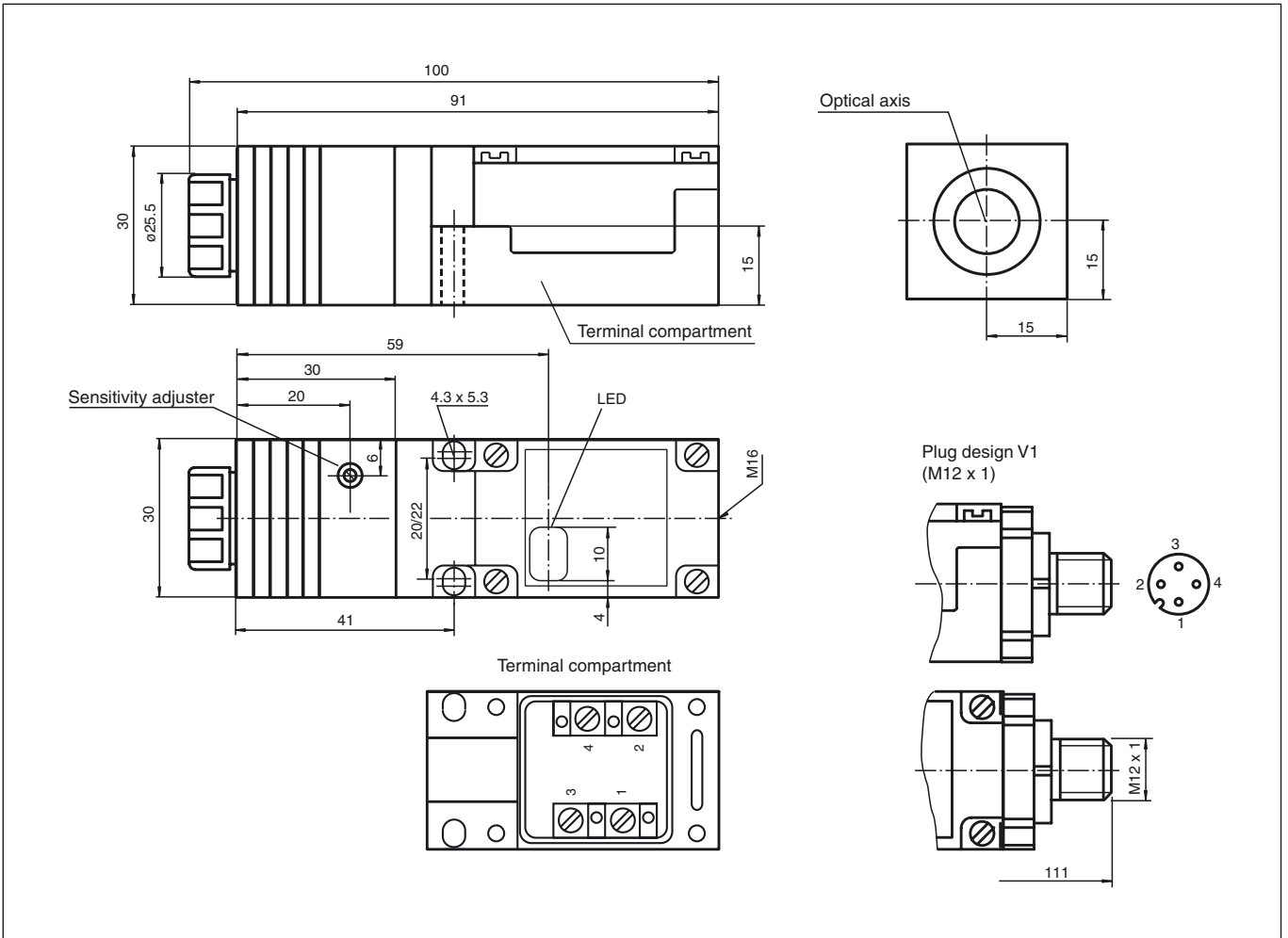

Electrical connection

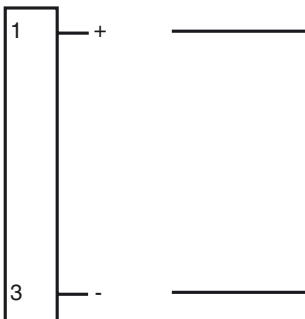

○ = light on, ● = dark on

Selection table for fibre

	Model number	Range in mm	Detection range in mm	Fig.
fibre optic, single path with PVC coating	LCE 18-2,3-0,5-K2	600		1
	LCE 18-2,3-0,5-K9	600		4
fibre optic, single path with metal coating	LME 18-1,9-0,5-K9	500		4
	LME 18-2,3-0,5-K10	600		5
	LME 18-2,3-0,5-K2	600		1
	LME 18-2,3-0,5-K3	600		2
	LME 18-2,3-0,5-K4	600		3
	LME 18-2,3-1,0-K2	600		1
	LME 18-2,3-2,0-K2	600		1
Glass fibre optics, single path with silicon coating	LSE 18-1,1-0,5-K9	100		4
fibre optic, reflex with PVC coating	LCR 18-2,7-1,0-K9		75	12
	LCR 18-3,2-0,5-K1		100	6
	LCR 18-3,2-0,5-K2		100	7
	LCR 18-3,2-2,0-K2		100	7
	LMR 18-1,1-0,5-K3		10	8
	LMR 18-2,3-0,25-K3		45	8
Glass fibre optics, reflex with metal coating	LMR 18-2,3-0,5-K2		45	7
	LMR 18-2,3-0,5-K3		45	8
	LMR 18-2,3-0,5-K7		45	11
	LMR 18-2,7-0,5-K9		75	12
	LMR 18-3,2-0,5-K1		100	6
	LMR 18-3,2-0,5-K5		100	10
	LMR 18-3,2-1,0-K1		100	6
	LMR 18-3,2-1,0-K5		100	10
	LMR 18-3,2-2,0-K1		100	6
	LMR 18-3,2-2,0-K4		100	9
LMR 18-3,2-3,0-K1		100	6	
fibre optic, reflex with silicon coating	LSR 18-2,3-0,5-K12		45	13
	LSR 18-3,2-0,5-K1		100	6

Other lengths and end pieces available on request

Fig. 1

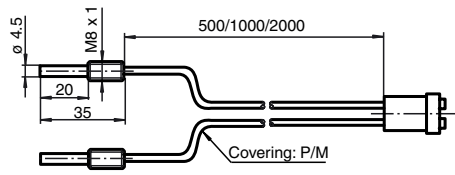

Fig. 2

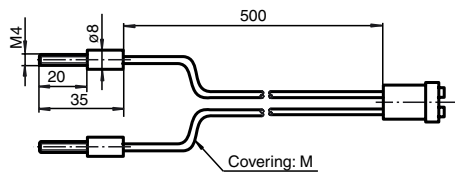

Fig. 3

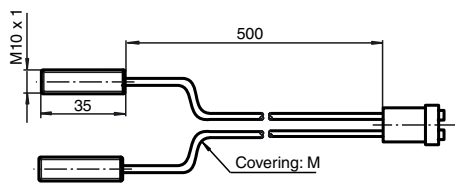

Fig. 4

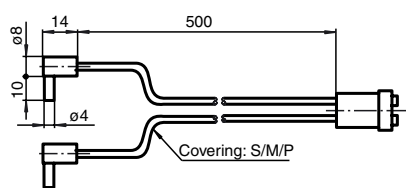

Fig. 5

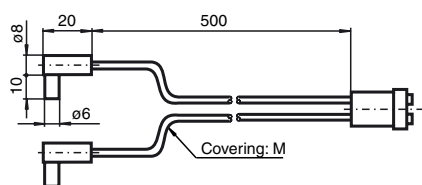

Fig. 6

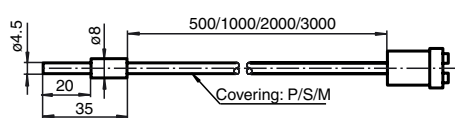

Fig. 7

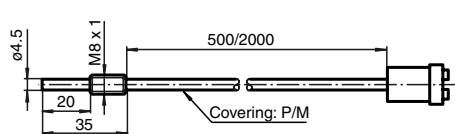

Fig. 8

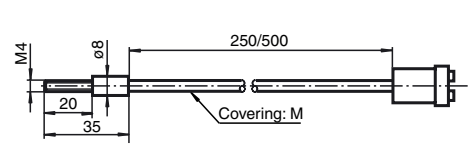

Fig. 9

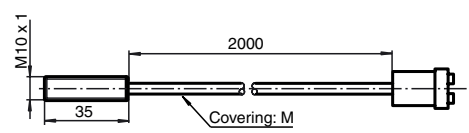

Fig. 10

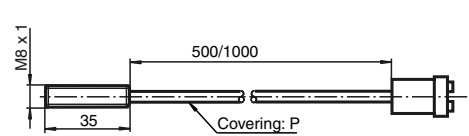

Fig. 11

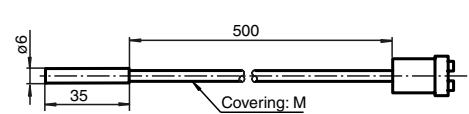

Fig. 12

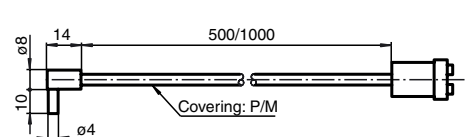
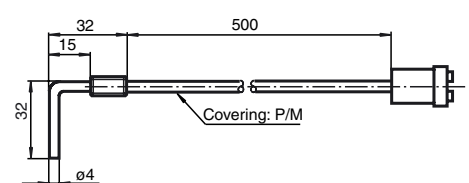

Fig. 13



Adapter

