



- 1-channel
- 24 V DC nominal supply voltage
- 2 switching points operate on 2 output relays
- High/low alarm can be selected for each switching point
- Mode of operation of the relay adjustable separately
- Hysteresis 1 % ... 10 % of measuring range
- Lead breakage monitoring (can be deactivated)
- 3 1/2-digit LC-display for switching points and limit values
- All operating and indicator elements on the front side

0 mA ... 20 mA, 0 V ... 10 V DC  
**KFD2-GS-1.EU**

Successor KFD2-GU-1 or KFD2-GS-1.2W

**Function**

The trip amplifiers are used in measurements of current or voltage. High alarm indicates that the alarm is activated when a limit is exceeded and is reset when another limit is not met. The hysteresis which is the difference between these values, is adjustable. Low alarm, means that the alarm is activated when a limit is not met.

**Application**

Monitoring of limit values when measurement with current/voltage unit signals.

**Connection**

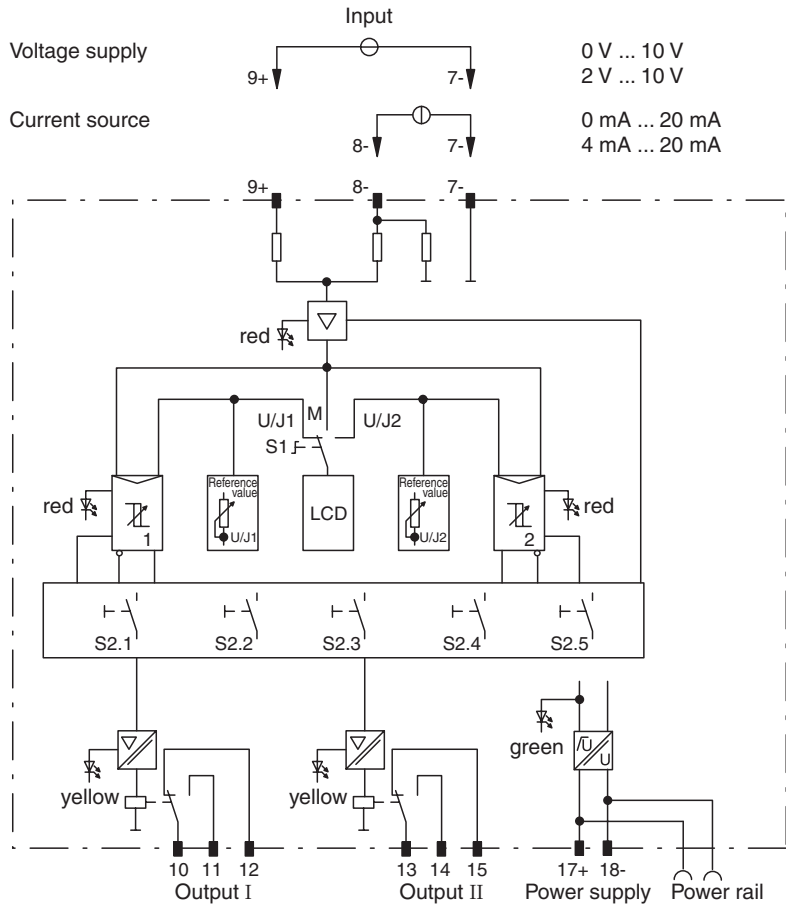

**Composition**

**Front View**

Housing type B2 (see system description)

- Switch S1  
Display selection switch
- LED yellow:  
Switching status output I
- LED green:  
Power supply
- LED red:  
Fault signal
- LED yellow:  
Switching status output II
- LED red:  
Alarm II
- Potentiometer T1  
Trip value channel I
- Potentiometer T2  
Trip value channel II

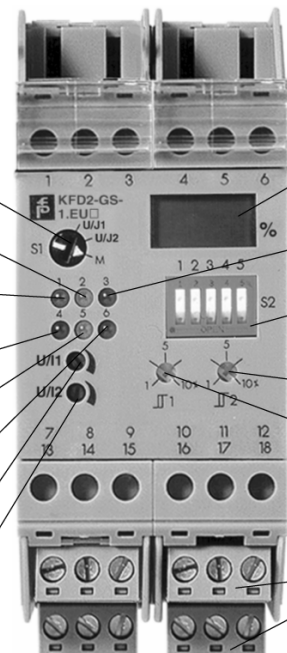

- LC-display
- LED red:  
Alarm I
- Switch S2  
Function setting
- Potentiometer 2  
Hysteresis channel II
- Potentiometer 1  
Hysteresis channel I
- Removable terminals  
green

Release date 2005-12-05 15:12 Date of issue 2005-12-05 034761\_ENG.xml

<b>Supply</b>	
Rated voltage	18 ... 32 V DC within the supply tolerance
Power consumption	approx. 2 W
<b>Input</b>	
Measurement range	<u>voltage</u> terminals 9+, 7-: 0 ... 10 V ; 100 kΩ <u>current</u> terminals 8+, 7-: 0 ... 20 mA ; 50 Ohm
<b>Output</b>	
Output I	limit value 1: terminals 10, 11, 12
Output II	limit value 2: terminals 13, 14, 15
Contact loading	253 V AC ,2 A, cos φ >0.6
Mechanical life	2 x 10 <sup>7</sup> switching cycles
<b>Transfer characteristics</b>	
Deviation	0.2 % of measuring value + 1 digit
Influence of ambient temperature	<u>switching point</u> : 0.015 % / K of measuring range <u>display</u> : 0.01 % of measuring range
Influence of supply voltage	not measurable
Input delay	80 ms (rise time and energising delay of relay)
<b>Electrical isolation</b>	
Input/output	safe isolation acc. to DIN VDE 0106, rated insulation voltage 253 V <sub>eff</sub>
Input/power supply	safe isolation acc. to DIN VDE 0106, rated insulation voltage 253 V <sub>eff</sub>
Output/power supply	function insulation acc. to DIN EN 50178, rated insulation voltage 50 V <sub>eff</sub>
Output/output	safe isolation acc. to DIN VDE 0106, rated insulation voltage 253 V <sub>eff</sub>
<b>Standard conformity</b>	
Insulation coordination	acc. to DIN EN 50178
Electrical isolation	acc. to DIN EN 50178
Electromagnetic compatibility	acc. to EN 50081-2 / EN 50082-2
Climatic conditions	acc. to DIN IEC 721
<b>Ambient conditions</b>	
Ambient temperature	-25 ... 65 °C (248 ... 338 K)
<b>Mechanical specifications</b>	
Protection degree	IP20
Mass	approx. 250 g
<b>Data for application in conjunction with hazardous areas</b>	
Supply	
Safety maximum voltage U <sub>m</sub>	40 V DC

Notes

**LC display**

The reference or actual values are displayed in % of the measurement range.

**LC display selector switch**

The S1 switch can be used to determine which value (actual or reference value) will be transferred to the LC display.

S1 in pos. T1:  
switch point 1 (reference value or limit value 1)

S1 in pos. T2:  
switch point 2 (reference value or limit value 2)

S1 in pos. M: actual value

**Potentiometers T1, T2**

The switch points or the limit values are set using potentiometers T1 or T2.

T1: adjustment of switch point 1 (reference value or limit value 1)

T2: adjustment of switch point 2 (reference value or limit value 2)

**Potentiometer hysteresis 1 and 2**

Potentiometers are used for the adjustment of the hysteresis of the individual switch points in the range of 1 ... 10 % (KFD2-GS-1.EU) or 0,1 ... 1 % (KFD2-GS-1.EU.LZ) based on measurement value.

1. Hysteresis switch point 1 (reference value or limit value 1)
2. Hysteresis switch point 2 (reference value or limit value 2)

**DIP switch S2**

Switch	Position	Function
S2.1	OPEN	High alarm output I
	-	Low alarm output I
S2.2	OPEN	Relays closed on alarm state output I
	-	Relays open in alarm state output I
S2.3	OPEN	Lead breakage monitoring off
	-	Lead breakage monitoring on
S2.4	OPEN	High alarm output II
	-	Low alarm output II
S2.5	OPEN	Relays closed on alarm state
	-	Relays open in alarm state

Release date 2005-12-05 15:12 Date of issue 2005-12-05 034761\_ENG.xml