

Ultrasonic sensor UB500-30GM-E2-V15



Features

- Switch output
- 5 different output functions can be set
- TEACH-IN input
- Synchronisation options
- Deactivation option

Electrical connection

Standard symbol/Connections:
(version E2, pnp)

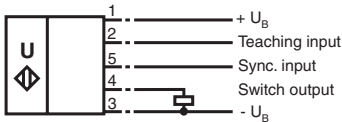

Connector V15



Dimensions

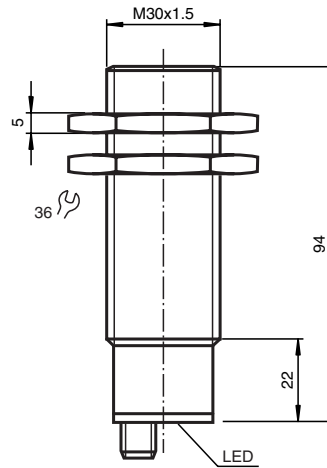

Technical data

General specifications

Sensing range	60 ... 500 mm
Unusable area	0 ... 60 mm
Standard target plate	100 mm x 100 mm
Transducer frequency	approx. 380 kHz
Response delay	approx. 38 ms

Indicators/operating means

LED green	"Power on", TEACH-IN function object detected
LED yellow	indication of the switching state, TEACH-IN function-no object detected
LED red	"Error", object uncertain

Electrical specifications

Operating voltage	20 ... 30 V DC , ripple 10 % _{SS}
No-load supply current I ₀	≤ 60 mA

Input

Input type	1 TEACH-IN input, operating distance 1: -U _B ... (-U _B + 2 V), operating distance 2: (+U _B - 2 V) ... +U _B 1 synchronous input level 0: -U _B ... (-U _B + 1 V), level 1: (-U _B + 5 V) ... +U _B Input impedance 27 kOhm Synchronisation pulse: ≥ 100 μs Synchronisation pulse pause: ≥ 100 μs
Pulse length	

Synchronisation frequency

Common mode operation	≤ 150 Hz
Multiplex operation	≤ 150/n Hz , n = number of sensors

Output

Output type	1 switch output E2/E3, pnp, normally open/closed, programmable
Repeat accuracy	≤ 1 %
Rated operational current I _e	200 mA , short-circuit/overload protected
Voltage drop U _d	U _B - 3 V
Switching frequency f	max. 13 Hz
Range hysteresis H	≤ 1 % of the set operating distance
Temperature influence	0,17 % / K

Standard conformity

Standards	EN 60947-5-2
-----------	--------------

Ambient conditions

Ambient temperature	-25 ... 70 °C (248 ... 343 K)
Storage temperature	-40 ... 85 °C (233 ... 358 K)

Mechanical specifications

Protection degree	IP65
Connection	connector V15 (M12 x 1), 5 pin
Material	
Housing	brass, nickel-plated, plastic components PBT
Transducer	epoxy resin/hollow glass sphere mixture; polyurethane foam
Mass	145 g

Function

Synchronization

The sensor features a synchronization input for the suppression of mutual interference. It can be synchronized by applying a square wave voltage. The falling edge of a synchronization pulse at the synchronization input starts a measuring cycle. A low level > 1 s or an open synchronization input will result in the non-synchronized normal operation of the sensor. A high level at the synchronization input disables the sensor. Synchronization cannot be performed during TEACH-IN and vice versa.

Two operating modes are possible:

1. The sync. inputs of 2 ... 5 Sensors are connected with each other. The sensors synchronize themselves and operate cyclically (multiplex mode).
2. Multiple sensors can be controlled by the same synchronization signal. The sensors are synchronized.
3. The synchronization pulses are sent cyclically to individual sensors. The sensors operate in multiplex mode.

In case of synchronized operation, the response time of the sensor increases due to a longer measuring cycle time caused by synchronization.

Note:

If the option for synchronization is not used, the synchronization input has to be connected to ground (0V) or the sensor has to be operated via a V1 cable connector (4-pin).

Setting the switching points

The ultrasonic sensor features a switch output with two teachable switching points. These are set by applying the supply voltage -UB or +UB to the TEACH-IN input. The supply voltage must be applied to the TEACH-IN input for at least 1 s. LEDs indicate whether the sensor has recognised the target during the TEACH-IN procedure. Switching point A1 is taught with -UB, A2 with +UB.

Five different output functions can be set:

Function	TEACH-IN procedure
Window mode, close function	<ul style="list-style-type: none"> - Set object to near switching point - Teach switching point A1 with -UB - Set object to far switching point - Teach switching point A2 with +UB
Window mode, open function	<ul style="list-style-type: none"> - Set object to near switching point - Teach switching point A2 with +UB - Set object to far switching point - Teach switching point A1 with -UB
1 switching point, close function	<ul style="list-style-type: none"> - Set object to near switching point - Teach switching point A2 with +UB - Cover sensor or remove all objects from sensing range - Teach switching point A1 with -UB
1 switching point, open function	<ul style="list-style-type: none"> - Set object to near switching point - Teach switching point A1 with -UB - Cover sensor or remove all objects from sensing range - Teach switching point A2 with +UB
Detection of object presence	<ul style="list-style-type: none"> - Cover sensor or remove all objects from sensing range - Teach switching point A1 with -UB - Teach switching point A2 with +UB

UB500-30GM-E2-V15

Characteristic curves/additional information

Characteristic response curves

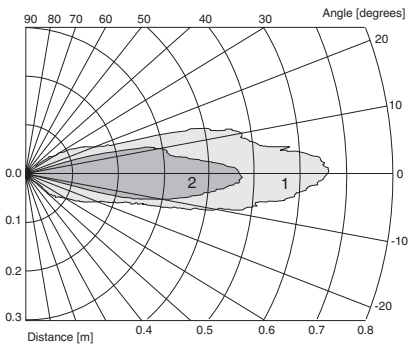

Curve 1: flat plate 100 mm x 100 mm
Curve 2: round bar, Ø 25 mm

Programmed switching output function

1. Window mode, normally open function
A1 < A2: object range →
2. Window mode, normally closed function
A2 < A1:
3. One switch point, normally open function
A1 → ∞:
4. One switch point, normally closed function
A2 → ∞:
5. A1 → ∞, A2 → ∞: Detection of object presence
Object detected: Switch output closed
No object detected: Switch output open

LED-Window

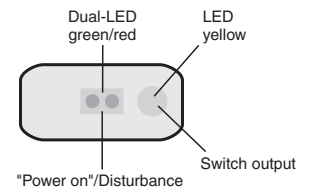

Default setting of switching points: A1 = blind range, A2 = nominal distance

Displays in dependence on operating mode	Green LED	Red LED	Yellow LED
Teach switching point			
Object detected	Flashing	Off	Off
No object detected	Flashing	Off	On
Object uncertain (TEACH-IN invalid)	Off	Flashing	Off
Normal operation	On	Off	Switching state
Interference (e.g. compressed air)	Off	Flashing	Previous state