



Model Number

ICC-16GK

Code carrier

Features

- Battery-free code carrier
- 28 bit fixcode
- Readable from the printed side
- Embeddable mountable in metal
- Protection degree IP67
- With thread M16 x 1

Accessories

IVZ-16G-EW

Screw-in tool

Dimensions

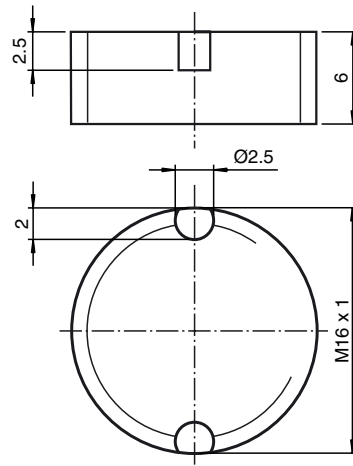

Technical data

General specifications

Operating frequency	250 kHz
Transfer rate	7.8 kBit/s

Memory

Type/Size	ROM 64 bit (28 bit code, 36 bit data security)
Read cycles	unlimited

Ambient conditions

Ambient temperature	-25 ... 70 °C (248 ... 343 K)
Storage temperature	-40 ... 85 °C (233 ... 358 K)

Mechanical specifications

Protection degree	IP67 according to EN 60529
Material	
Housing	PBT
Encapsulation compound	CY 221/HY 2966

Notes

the code carrier is read, when the surface bearing the Pepperl+Fuchs logo is facing the read head.