



Model Number

UC1000-30GM-E6-V1

Single head system

Features

- 2 independent switch outputs
- Switch points can be taught-in
- Window function can be selected
- Temperature compensation
- Compact design
- Plug connection

Diagrams

Characteristic response curves

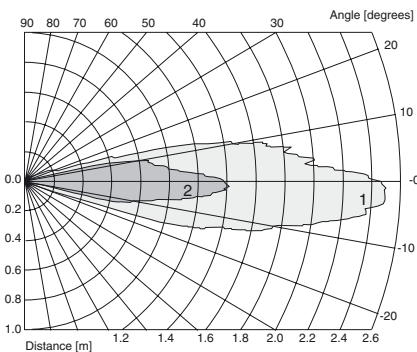

Curve 1: flat plate 100 mm x 100 mm
Curve 2: round bar, Ø 25 mm

Release date: 2013-02-26 15:42 Date of issue: 2013-02-26 027677_eng.xml

Technical data

General specifications

Sensing range	200 ... 1000 mm
Unusable area	0 ... 200 mm
Standard target plate	100 mm x 100 mm
Transducer frequency	approx. 175 kHz
Response delay	≤ 100 ms

Indicators/operating means

LED yellow	switching state output 1, program function output 1 switching state output 2, program function output 2
LED red/green	solid green: Power on green, flashing: program function, object detected solid red: Connector removed red, flashing: error, program function object not detected
Temperature/TEACH-IN connector	Temperature compensation, Switch points programming, output function setting

Electrical specifications

Operating voltage U_B	10 ... 30 V DC, ripple 10 % _{SS}
Power consumption P_0	≤ 600 mW

Output

Output type	2 switch outputs PNP, NO/NC
Rated operating current I_e	200 mA, short-circuit/overload protected
Voltage drop U_d	≤ 3 V DC
Repeat accuracy	≤ 1 %
Switching frequency f	≥ 5 Hz
Range hysteresis H	≤ 3.2 % of the set operating distance
Temperature influence	< 2 % of full-scale value (≤ 0.2 % / K without temperature compensation)

Standard conformity

Standards	EN 60947-5-2
-----------	--------------

Ambient conditions

Ambient temperature	-25 ... 70 °C (-13 ... 158 °F)
Storage temperature	-40 ... 85 °C (-40 ... 185 °F)

Mechanical specifications

Connection type	Connector M12 x 1, 4-pin
Protection degree	IP65
Material	
Housing	High grade stainless steel
Transducer	epoxy resin/hollow glass sphere mixture; foam polyurethane, cover PBT
Mass	140 g

Dimensions

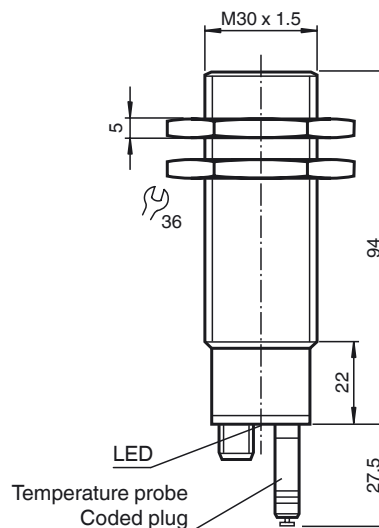

Electrical Connection

Standard symbol/Connection:
(version E6, pnp)

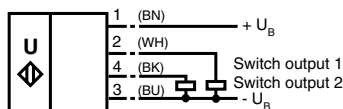

Core colours in accordance with EN 60947-5-2.

Pinout

Connector V1



Description of the sensor functions

This ultrasonic sensor features a four-pole temperature/TEACH-IN plug, that can be connected in four different positions. These have the following significance.

Plug position	Meaning
A1	TEACH-IN switching point A1
A2	TEACH-IN switching point A2
E2/E3	Switching: 2 independent switching positions/window function
T	Temperature compensation

Description of the TEACH-IN procedure

- Remove temperature plug
- Cut and restore supply voltage (e.g. by removing and replacing unit plug)

TEACH-IN of switching points 1 or 2

- Set object to desired switching point
- Connect TEACH-IN plug in pos. A1 or A2
- Green LED flashes when object detected, red LED flashes when no object detected
- Pull the plug (the current object position is taught and stored when the plug is removed!!)

TEACH-IN of switching function

- Connect TEACH-IN plug in pos. E2/E3
- The yellow LED indicates the switching function
- E2: 2 independent switching points (NO)
- E3: window function: switch output 1 NO, switch output 2 NC
- Pull the plug when the desired function is activated, otherwise reconnect the TEACH-IN plug in pos. E2/E3
- Pull plug

Completing the TEACH-IN procedure

- Connect TEACH-IN plug in pos. T. Temperature compensation is now activated.

If the temperature plug has not been plugged in within 5 minutes, the sensor will return to normal mode without temperature compensation.

Default setting

- A1: unusable area
- A2: nominal sensing range

LED Displays

Additional Information

Programmed switching output function

Position of insert
Switch output functions

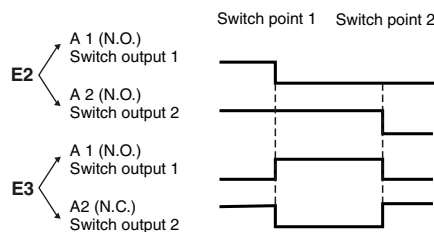

LED-Window

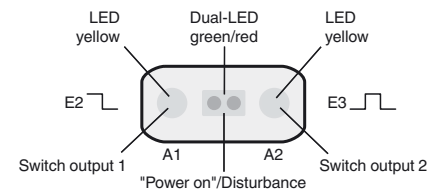

Displays depending on position of temperature/ TEACH-IN plug position	Green dual LED	Red dual LED	Yellow LED A1/E2	Yellow LED A2/E3
TEACH-IN switching point output A1 Object detected No object detected	flashes off	off flashes	flashes flashes	off off
TEACH-IN switching point output A2 Object detected No object detected	flashes off	off flashes	off off	flashes flashes
TEACH-IN of switch output functions: E2: 2 independent switching positions E3: window function	on on	off off	flashes off	off flashes
Normal mode temperature compensated plug pulled/shorted	on off	off on	switching state A1	switching state A2
Interference (e.g. compressed air)	off	flashes	previous state	previous state

LED-Window

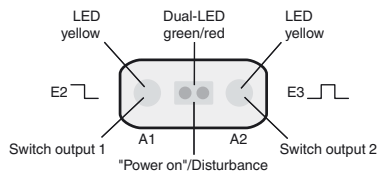

Mounting conditions

If the sensor is installed in places where the operating temperature can fall below 0 °C, the BF30, BF30-F or BF 5-30 fixing clamp must be used.