



- Performance hollow shaft encoder for heavy duty industries
- Hybrid bearings for extended lifetime
- High vibration and shock resistance
- Electrically insulated shaft; up to 2,5 kV



## Technical data

Operating temperature	-40 °C .. +100 °C
Ingress protection class [IEC 60529]	IP67 (IP66 at shaft inlet)
Vibration [IEC 60068-2-6]	≤ 200 m/s <sup>2</sup>
Shock [IEC 60068-2-27]	≤ 1500 m/s <sup>2</sup>
Cover material	Aluminium (anodized)
Weight	1400 g
Shaft load (axial/radial)	100 N / 300 N
Rotational speed max	6000 rpm
Shaft material	Stainless steel with insulated hybrid bearings
Short circuit protected	No
Polarity protected	Yes
Current consumption	40 mA at 24 Vdc (Max. 60 mA)
Output load	120 Ω
Output frequency max	200 kHz
Cable length max	150 m at 90 pF
Channel separation	90° el ± 25° el
Dividing error	±50° el

## Encoder configuration

Type	XHI
Model	801 Extra robust
Shaft type	Ø17 mm taper hollow shaft
Flange type	86-flange
Resolution	1024
Power supply	9-30 Vdc
Output signal	1Vpp
Connection type	Cable gland
Connecting direction	Adjustable
Cable gland dimension	M20 for Ø8-11 mm cables
Number of channels	6
Overvoltage protection	Available upon request
Torque support	120 degrees torque bracket
Advanced Diagnostic System	Available upon request

## Dimensions

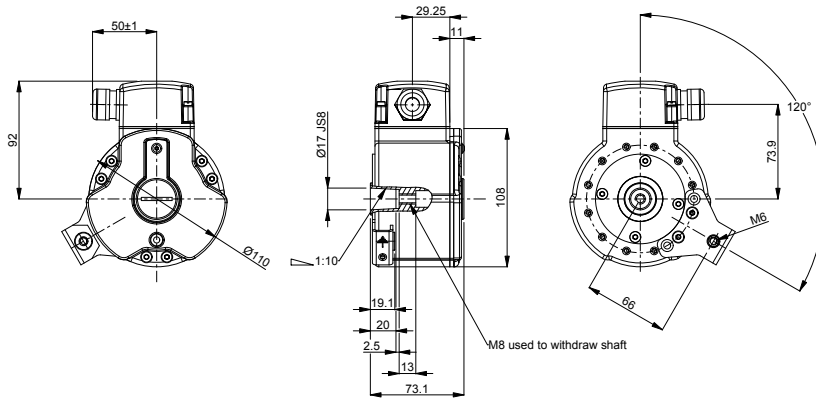

## Output signals

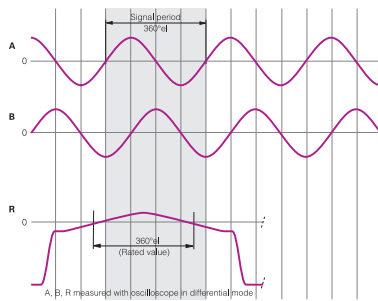

## Pin configuration

Function	Terminal
+E Volt	K
0 Volt	H
R	B
R inverted	A
B	D
B inverted	C
A	F
A inverted	E
Status	L
Shield	Case or G

## Ordering information

Part number

801712-01