

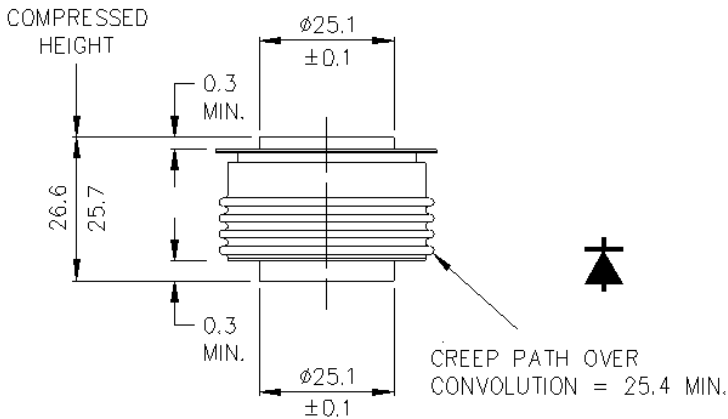

∅3.6/3.5x1.8 MIN.
DEPTH 2-HOLES, ONE
IN CATHODE AND ONE
IN ANODE.

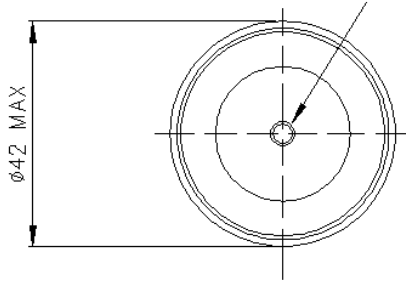

Weight 140g

Device family	Clamp part number	clamp force	T _{JMAX}	Maximum allowed height	Outline
		kgf	°C	mm	
Rectifier Diodes (W), Fast Diodes (M), Extra Fast Diodes (F) and High-power Sonic Fast Recovery Diodes (E) YH Housing	XK045SA056M	450	190	55	WC1
	XK045DA056M			86	WC2
	XK045DT056M			86	WC3
	XSK0500Dx042M025	500	190	25	WC58-WC60
	XSK0500Dx042M031			31	
	XSK0500Dx042M038			38	
	XSK0500Dx042M044			44	
	XSK0500Dx042M050			50	
	XSK0500Dx042M057			57	
	XSK0500Dx042M063			63	
	XSK0500Dx042M069			69	
	XSK0500Dx042M076			76	

XK045D/Sx

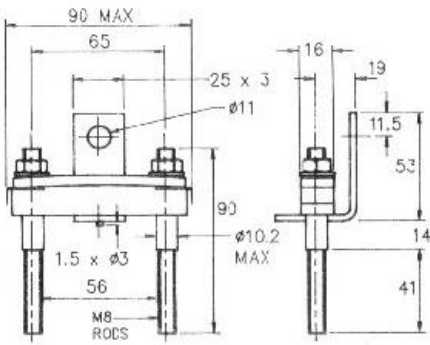

WC1 – SA Style

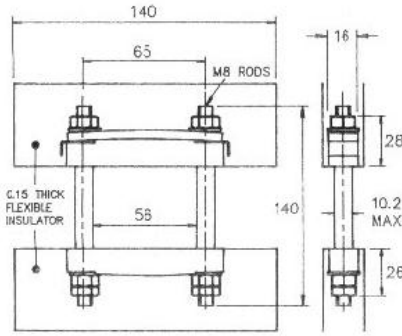

WC2 – DA Style

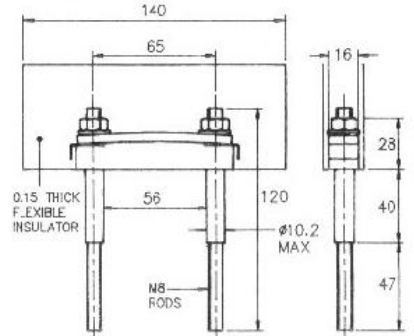

WC3 – DT Style

XSK0500Dx

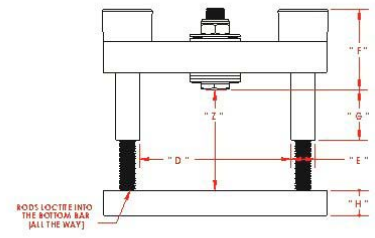
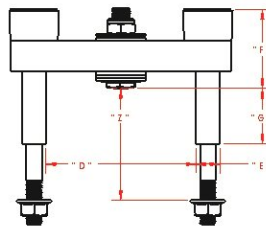
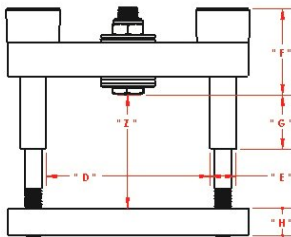
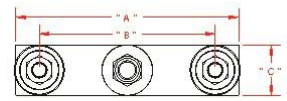
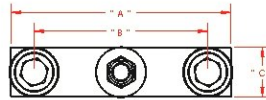
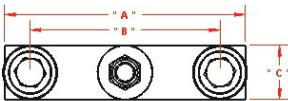

WC58 – DA Style

WC59 – DT Style

WC60 – DF Style

Dimensions (mm)

- A – 69.85
- B – 54.00
- C – 15.88
- D – 42.00
- H – 12.70

Part #'s	" Z " min	" Z " max	" G " (ref)	
			00500	00900
XSK xxxxx xx 042 M 025	19.05	25.40	14.98	11.93
XSK xxxxx xx 042 M 031	25.40	31.75	14.98	17.01
XSK xxxxx xx 042 M 038	31.75	38.10	19.81	19.05
XSK xxxxx xx 042 M 044	38.10	44.45	21.84	22.09
XSK xxxxx xx 042 M 050	44.45	50.80	24.89	26.92
XSK xxxxx xx 042 M 057	50.80	57.15	29.97	28.95
XSK xxxxx xx 042 M 063	57.15	63.50	32.00	32.00
XSK xxxxx xx 042 M 069	63.50	69.85	34.79	37.08
XSK xxxxx xx 042 M 076	69.85	76.20	39.87	37.08

Force [Kgf]	" E "	" F " (ref)	Bolt Type
500	8.64	32	M6
900	8.64	35.05	M6