



DIRECTED ENERGY, INC.

**PCO-7810
Laser Diode Driver Module**

**INSTALLATION
and
OPERATION
MANUAL**



**Directed Energy, Inc.
An IXYS Company
2401 Research Blvd. Suite 108
Fort Collins, CO. 80526
TEL: 970-493-1901
FAX: 970-493-1903
EMAIL: deiinfo@directedenergy.com
WEB: www.directedenergy.com**

Doc #0100-0228 Rev 2

Table of Contents

Introduction.....	2
Design Considerations.....	3
Inputs and Control Functions	4
DB-9 Inputs	4
DIP Switch Settings And Frequency Adjustment.....	5
Circuit Operation And Laser Diode Interconnection	6
Current Measurement.....	9
Specifications	10
Mechanical Specifications	11
Typical Output Waveforms	12
Warranty.....	12

Introduction

The PCO-7810 is a compact, economical OEM pulsed laser diode driver module. It is designed to provide extremely fast, high current pulses to drive laser diodes in range finder, LIDAR, atmospheric communications and other applications requiring high current, nanosecond pulses.

The PCO-7810 features an internal high voltage DC power supply to support the high current output, and an internal trigger generator. With the supplied heatsink, the PCO-7810-40-4 can operate at pulse repetition frequencies up to 200KHz at 40A output current. The PCO-7810-50-12 can operate at pulse repetition frequencies up to 67KHz at 50A output current.

The PCO-7810 is designed to be an Original Equipment Manufacturer (OEM) style product in which the current pulse may be easily tailored to the diode type and application – contact DEI for more information.

Mounting pads are provided to mount the laser diode directly to the driver. The four-hole mounting pattern accepts TO-18, TO-5, TO-52, 5.6MM, and 9MM packages (PerkinElmer Optoelectronics R, S, T and U packages), as well as other packages of similar dimensions and lead spacing, mounted perpendicular to the driver circuit board. To facilitate different packages and mounting preferences, there are two solder pads on the end of the board to accept various laser diode packages mounted on axis to the driver. Furthermore, the diode can be connected remotely from the driver using a low-impedance stripline interconnection (available from DEI) between the mounting pads and the leads of the laser diode.

A current monitor output may be viewed with an oscilloscope, providing a straightforward means to observe the diode current waveform in real-time.

The design is inherently temporally stable with large variations in ambient temperature and equally rugged with respect to mechanical parameters.

Design Considerations

Many elements and stray components may affect the PCO-7810 performance. One of the most important, which affects the performance greatly, is stray inductance. This is a combination of the output current loop's circuit elements and the physical inductance of that loop. The magnitude of this inductance has a great effect on the pulse width and the peak output current. The PCO-7810 design minimizes the stray inductance of the circuit components to approximately 2nH. However, the laser diode that it will drive and the means by which the diode is connected to the PCO-7810 also contribute to the stray inductance. This additional inductance, which is added to the system and will affect the output, is something that the user can minimize by appropriate diode package choice and interconnections between the diode and driver.

Table 1 lists several laser diode package types and their Equivalent Series Inductance (ESL). Although many of the laser diode packages have the appearance of a good low inductance design, they are not. For example, the 8-32 STUD (line # 2) from all outward appearances is a low inductance package, however it has one of the largest ESL's of the devices listed. As shown in Table 1, this leaves the laser diode as the largest contributor of the total inductance.







#	PACKAGE STYLE	PACKAGE INDUCTANCE
1	 Dip 14 Leads out top	15.7nH
2	 8-32 STUD	12nH
3	 10-32 STUD	11nH
4	 TO-5 (2 lead)	9.6nH
5	 TO-52	6.8nH
6	 Long Horn 14 Pin	6.4nH
7	 CD9mm	5.2nH
8	 KOVAR Gold Plate	5.0nH
9	 COPPER	3.6nH
10	 COPPER	1.56nH

Table 1
Package Style Vs Package Inductance

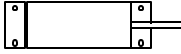
Inputs and Control Functions

Table 2 below provides the pin outs of the DB-9 connector and connector J1. Figure 1 provides the component side silk of the PCO-7810 to facilitate locating the various components mentioned in this section.

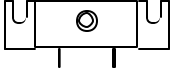
DB-9 Connector	
PIN 1	GATE (CMOS Into 1K Ohm)
PIN 2	OSCILLATOR ENABLE (CMOS Into 10K Ohm)
PIN 3	HV BOOST DISABLE (CMOS Into 1K Ohm)
PINS 4 & 5	+24VDC
PINS 6,7,8,9	GND
Connector J1	
PIN 1	GND
PIN 2	CONDUCTOR

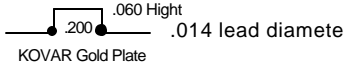
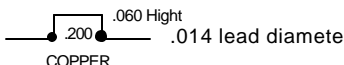
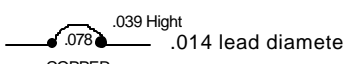
Table 2. PCO-7810 Connector Pin Out

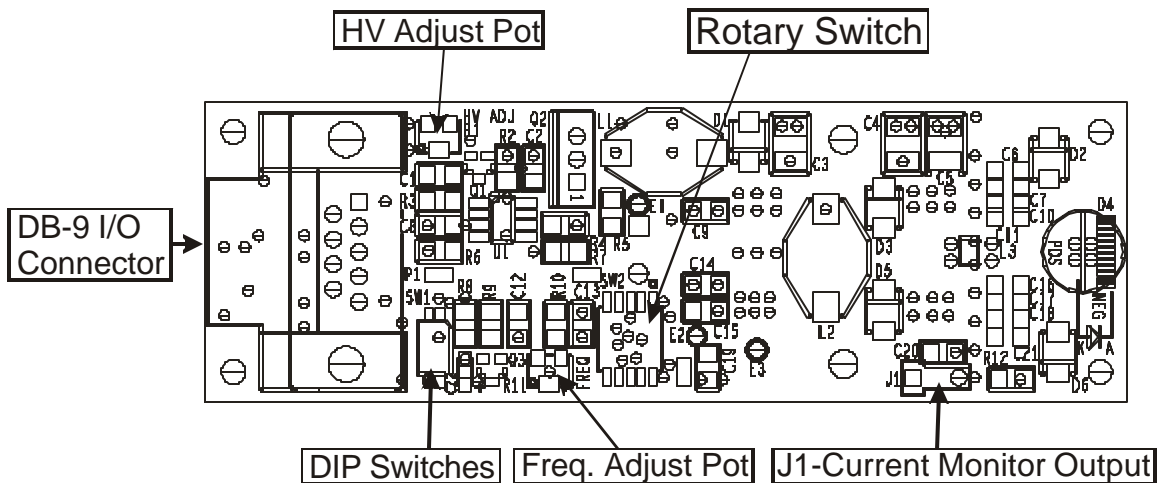

Figure 1. Component side silk

DB-9 Inputs

Referring to the above pin outs, there are four inputs to the PCO-7810 through the DB-9 connector: Trigger (GATE), Oscillator Enable, HV Boost Disable and Support Power (+24VDC).

The **GATE** input is only required if the user chooses to externally trigger the driver. If the output is triggered by the internal oscillator, the GATE input is not required. If the GATE input is used, the PCO-7810 generates an output pulse on the leading edge of the gate input. If the GATE input is used, it should be CMOS into 1K Ohm, with a pulse width of 50ns to 100ns. If it is not used, the internal oscillator is used to set the pulse recurrence frequency.

The rotary switch labeled SW2 controls whether the internal oscillator is used to gate the driver, or an external gate input is required. If in position 1 a GATE input is required. IF SW2 is in positions 2-8 the internal oscillator is used to set the output pulse frequency.

The **OSCILLATOR ENABLE** input enables the internal oscillator. If the driver is being triggered internally, the output may be turned on and off by enabling and disabling this input. The OSCILLATOR ENABLE input is internally pulled high. Therefore if it is not connected or if it is connected to CMOS +5V, the Oscillation function is enabled. If it is grounded, the Oscillation function is disabled.

The **HV BOOST DISABLE** input disables the internal high voltage DC power supply. Please note that when the HV Boost is disabled, the DC power supply will still generate a 24V output. If the oscillator is enabled, this will result in a pulse of approximately 4A on the output of the driver. Therefore in order to completely disable the driver, either disconnect the input gate, disable the internal oscillator, and/or remove the +24VDC input power. The disable is connected to CMOS +5V to disable the HV power supply. If it is grounded or not connected, the power supply is enabled.

DIP Switch Settings And Frequency Adjustment

FREQUENCY is adjusted using the FREQ adjust potentiometer, and positions 2-8 of the Rotary switch. Setting the Rotary switch to the following positions controls the range of the frequency. The potentiometer is then used to vary the frequency within this range (clockwise increases frequency, counter-clockwise decreases frequency).

Rotary Switch Position	Frequency Range
1	External Osc.
2	15Hz to 68Hz
3	50Hz to 270Hz
4	200Hz to 1kHz
5	775Hz to 4kHz
6	3.5kHz to 17kHz
7	13kHz to 65kHz
8	25kHz to 135kHz
9	50kHz to 275kHz
10	Osc. Off

The DB-9 connector is a standard 9 pin (male) DSUB connector (AMP 747250-4 or equivalent). It mates with a 9 pin DSUB socket (female) connector)

Connector J1 is the output of the current monitor. It is an FCI/Berg (www.berg.com) #65500-236 one-row header on 0.1" centers. The header mates with an FCI/Berg Mini-Latch Housing, part #65039-034 or equivalent, using FCI/Berg mating receptacles #48236-000 or equivalent.

Circuit Operation And Laser Diode Interconnection

The internal **high voltage DC power supply** is capable of approximately 235V maximum voltage. The maximum average current that the high voltage supply must provide is determined by the pulse recurrence frequency required for the user's application.

Equation 1 has been derived in order to approximate ($\pm 20\%$) the current requirement (I_{PS}) of the high voltage power supply. It is a function of the total input capacitance (the Pulse Forming Network C_{PFN} , the FET capacitance C_{FET} , and the stray C_{STRAY}), the high voltage set point (V_{IN}), and the frequency of each application (f).

$$1. I_{PS} = (C_{PFN} + C_{FET} + C_{STRAY}) * V_{IN} * f ,$$

where the various capacitances are given in Table 3.

PCO-7810 MODEL	40-4	50-12
C_{PFN}	500pF	2600pF
C_{FET}	120pF	120pF
C_{STRAY}	200pF	200pF

Table 3. C_{PFN} values of the PCO-7810

The output current of the PCO-7810 is adjusted by varying the DC power supply voltage using the potentiometer labeled "HV ADJ". The output current depends upon the available charge of the C_{PFN} . This charge is directly proportional to the applied voltage. Therefore, varying the voltage will cause the output current to vary respectively.

WARNING: The tab of the transistor labeled Q2 (the TO-220 package) and various other components on the driver are elevated to the potential of the high voltage DC supply (as high as 235V). During operation, care must be taken not to touch any of the components on the driver. Failure to observe this precaution may result in electrical shock to the user.

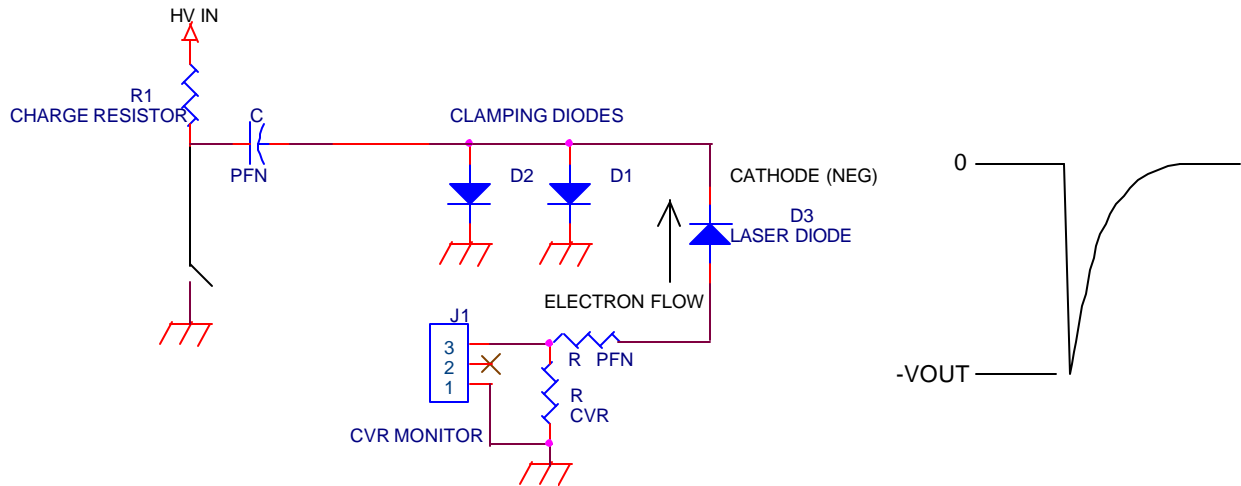

Figure 2. Equivalent Circuit Diagram and Output Waveform

Figure 2 is the equivalent circuit diagram of the PCO-7810 pulse section. It shows the location of the C_{PFN} mentioned previously and the location of the laser diode in respect to the entire circuit. When monitoring the output waveform through J1, the waveform should approximate the one in Figure 2. For more details about current monitoring and output waveforms refer to sections “Current Measurement” and “Typical Output Waveforms.”

D3 is the laser diode mounting location. It is marked on the silkscreen, and is separated in the middle with a line. The right-most two holes are negative (NEG) for the cathode while the other two are positive (POS) for the anode.

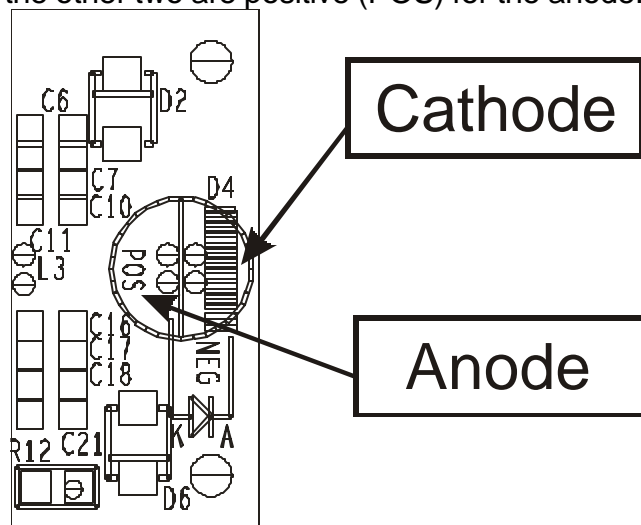

Figure 3. Cathode and Anode Pads on the PCB

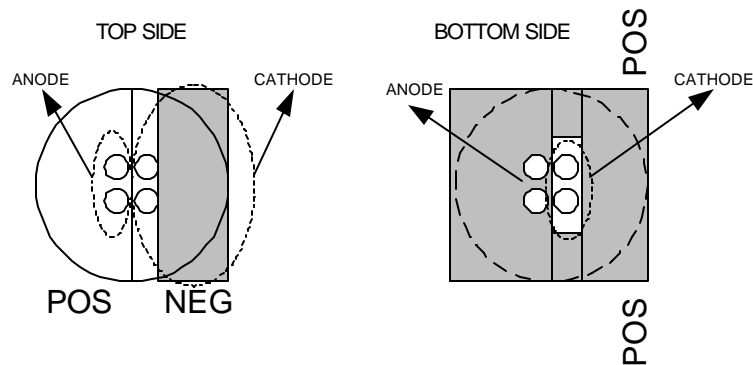

Figure 4. Detailed View of Cathode and Anode Pads on the PCB

Figures 3 and 4 show where the cathode and anode are located on the board. It is very important to mount the diode properly to avoid damaging it.

To facilitate different packages and user preferences, there are two strips of copper exposed; one on the top (component) side and one on the bottom (circuit) side of the PCB. The one on top is marked NEG and is for the cathode of the diode, while the one on the bottom is marked POS for the anode.

These pads are provided to facilitate mounting the diode perpendicular to the edge of the board (axial mount) as shown in Figure 5, rather than using the mounting holes. A stripline interconnect may also be soldered to these pads. The laser diode can then be soldered to the opposite end of the stripline, allowing remote mounting or installation of the laser diode.

These pads have no soldermask. If the diode case is connected to the anode of the diode, it is necessary to use an insulator when mounting the diode radially. This insulator should be for a TO-18 package, and will prevent the diode case from shorting to one of the pads. The driver is provided with kapton insulators.

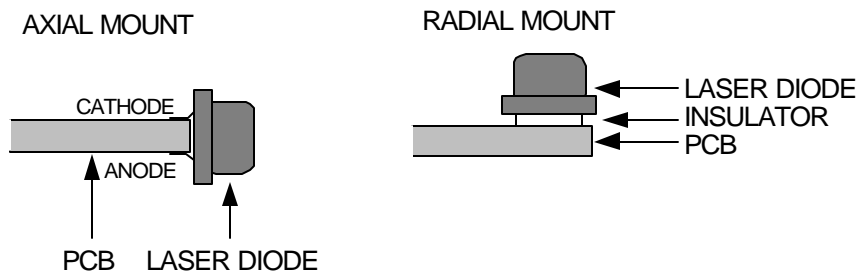

Figure 5. Axial and Radial Mounting Positions

It is possible to mount the laser diode remotely using a strip line. It is imperative that this strip line be of low inductance. As mentioned in the “Design Considerations” section, inductance can greatly affect the circuit performance. Strip line material designed for use with the PCO-7810 is available from DEI (DEI stock #1820-0030).

Current Measurement

The current monitor signal provided on the PCO-7810 is available through connector J1. The output waveform will look very similar to that in Figure 2. Waveform photographs from an oscilloscope through the driver's internal monitor are included in the "Typical Output Waveforms" section.

The physical topology of the PCO-7810's current monitor resistors yields a Current Viewing Resistor (CVR) with a bandwidth of approximately 500MHz. The scaling is 40A per 1V into a 50 Ω scope input.

The current monitor is not able to display a perfect rendition of the current given the peak and speed of the pulse. Because of the speed of the pulse, and some inductive and capacitive strays, there can be ringing on the viewing resistor. Pin 1 on connector J1 is the signal and pin 2 is the ground. For the best viewing results solder coaxial cable directly to the connector.

Specifications

The specifications in Table 4 below are for the standard models. For OEM applications, the PCO-7810 can be configured to specific pulse width and output current levels to meet individual customer requirements - contact DEI for more information.

SPECIFICATIONS		
PCO-7810 MODEL	40-4	50-12
Pulse Output Current Range (Controlled by HV adjust potentiometer mounted on board. Clockwise rotation increases output current)	4A to 40A	5A to 50A
Pulse Width (FWHM at maximum output current)	4ns ±1ns	12ns ±2ns
Rise Time (10% - 90%, Typical)	<2ns	2.5ns
Maximum PRF (Pulse Recurrence Frequency) at maximum output current	200KHz	67KHz
Maximum Duty Cycle (CW at maximum output current)	0.08%	
Jitter (1st Sigma)	<1ns	
Throughput Delay (Delay from external input trigger to output pulse)	33ns Typical	
Maximum Overshoot at maximum output current	5%	
Output Current Monitor	40A/V into 50 Ohms	
Trigger In (Optional)	CMOS into 1K Ohm, 50-100ns pulse width, <10ns rise time	
HV Boost Disable Input (The disable input is connected to CMOS +5V to disable the HV power supply. If it is grounded or not connected, the power supply is enabled)	CMOS into 1K Ohm	
Oscillator Enable Input (The enable input is connected to ground to disable the Oscillation function. If it is not connected or connected to CMOS +5V, the function is enabled)	CMOS into 1K Ohm	
Support Power	+24VDC	
MECHANICAL		
Input Connector (For +24VDC, HV disable input, Oscillator disable input and Ext. pulse input)	DSUB 9 pin (AMP 747250-4 or equivalent)	
Length	4.00 in. (10.16cm)	
Width	1.25 in. (3.18cm)	
Height (including heatsink)	1.4 in. (3.56cm)	
Weight (Approximate, including heatsink)	2.9 oz (82 grams)	
Operating Temperature	-20°C to +85°C	
<small>ALL SPECIFICATIONS MEASURED INTO A SHORTED OUTPUT AND MEASURED WITH THE INTERNAL CURRENT MONITOR SPECIFICATIONS SUBJECT TO CHANGE WITHOUT NOTICE • LASER DIODE NOT INCLUDED</small>		

Table 4
PCO-7810 Specifications

Mechanical Specifications

Figure 7 contains the dimensions for the PCO-7810. The mounting holes in the four corners (labeled "B") are 0.125" through-holes, to clear a #4 screw.

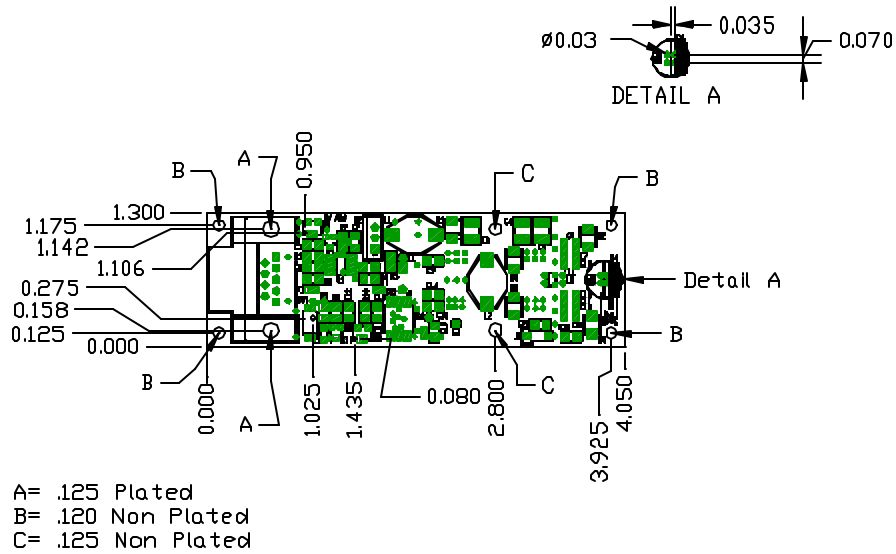
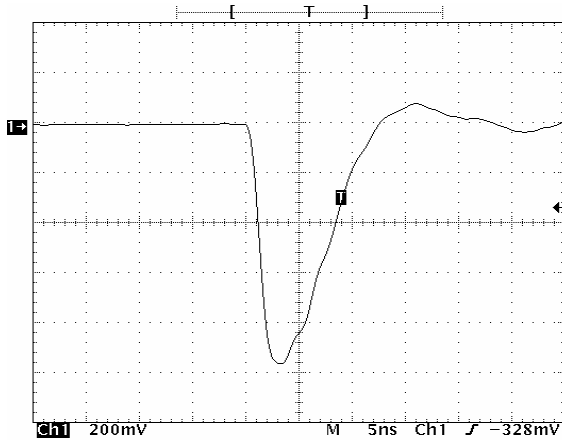

Figure 7: Detailed Mechanical Dimensions

Typical Output Waveforms

Below is a typical output waveform of the PCO-7810. The waveform is shown driving a short in place of the laser diode.



Model 40-4 Typical Output Waveform
4ns Pulse Width, 38A Output
5ns/Div horizontal scale, 8A/Div vertical

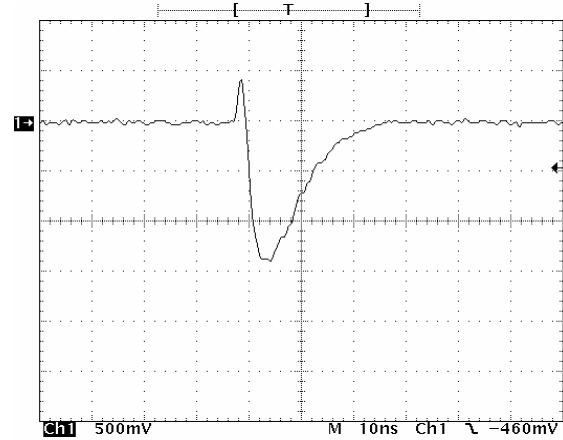

Model 50-12 Typical Output Waveform
12ns Pulse Width, 40A Output
10ns/Div horizontal scale, 20A/Div vertical

Warranty

There are no warranties, express or implied, including any implied warranty of fitness for a particular purpose nor any IMPLIED WARRANTY OF MERCHANTABILITY made by Directed Energy, Inc. (DEI) except as follows:

DEI warrants equipment manufactured by it to be free from defects in materials and/or workmanship under conditions of normal use for a period of one year from the date of shipment to the purchaser. DEI will repair or replace, at DEI's option, any product manufactured by it which is shown to be defective or fails to perform within specifications within one year from the date of shipment to the purchaser. OEM, modified and custom items of equipment are similarly warranted, for a period of ninety (90) days from date of shipment to the purchaser.

Equipment claimed to be defective must be returned, transportation prepaid, to DEI's factory in Fort Collins, Colorado within the warranty period. Returns must be preauthorized by contact with DEI's customer service department. Written documentation of such preauthorization shall be included with the returned item.

At DEI's discretion, DEI may elect to repair or replace the equipment claimed to be defective or refund the original purchase price, plus taxes and transportation charges incurred by the purchaser.

This Warranty shall not apply to any product that has been:

1. Repaired, worked on, or altered by persons unauthorized by DEI;
2. Subjected to misuse, neglect, or damage by others; or

3. Connected, installed, adjusted, or used in a manner not authorized in the instructions or specifications furnished by DEI.

This warranty is the purchaser's sole remedy for claimed defects in the equipment sold or manufactured by DEI. DEI's liability to the purchaser is limited to the repair or replacement of the claimed defective equipment or, at DEI's option, refund of the purchase price, taxes and transportation charges incurred by the purchaser. DEI will not be responsible for or liable to the purchaser for consequential losses or damages asserted to be attributable to a claimed defect in the equipment provided.

Changes made by DEI in the design or manufacture of similar equipment which are effected subsequent to the date of shipment of the warranted equipment to the purchaser are reflective of DEI's program of constant product development and improvement and shall not be construed as an acknowledgement of deficiency in the product shipped to purchaser. DEI will be under no obligation to make any changes to product previously shipped.