

## 32002935-001 ML7999 Weatherproofing Kit

### INSTALLATION INSTRUCTIONS

#### APPLICATION

The 32002935-001 Weatherproofing Kit, when properly installed, provides NEMA3 (IP54) weatherproofing for the ML7999 Universal Parallel Positioning Actuator.

#### SPECIFICATIONS:

**32002935-001 Kit Contents (Fig. 1):**  
32002915-001 Gasket Set  
32003508-001 Gasket  
32003519-001 O-Ring  
32003509-003 RTV Sealant Packet

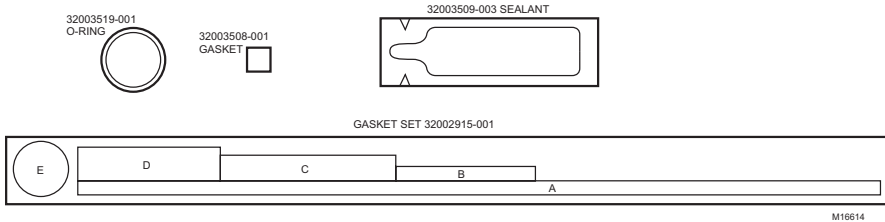


Fig. 1. 32002935-001 Weatherproofing Kit Contents

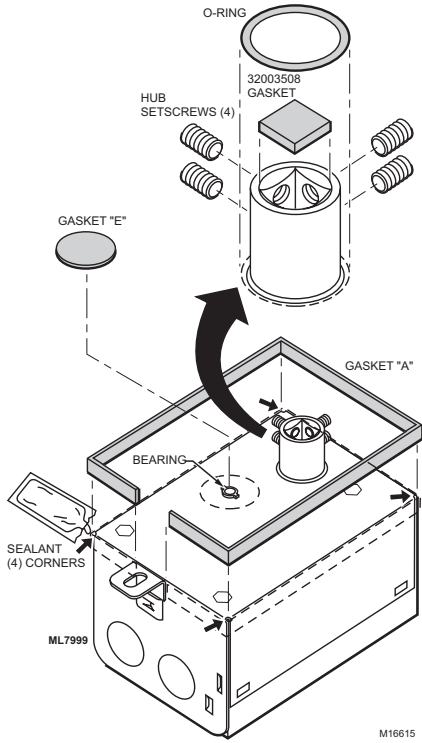
#### INSTALLATION

Follow these procedures to install the weatherproofing kit. See Fig. 2, 3 and 4.

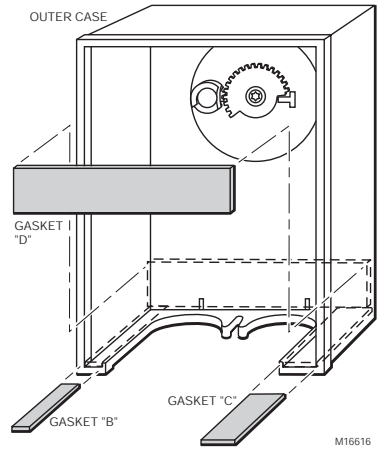
1. Remove the outer cover from the actuator by loosening the screw on the bottom of the actuator and pulling the two apart.
2. Remove gasket A from the 32002915 Gasket Set and, starting at the edge of the mounting bracket, carefully attach the weather-strip around the actuator frame, ending with the weather-strip end touching the other side of the mounting bracket, as shown in Fig. 2.
3. Remove gasket E from the 32002915 Gasket Set and place on the face of the actuator, over the bearing, as shown in Fig. 2.
4. Insert gasket 32003508 in the actuator hub, making sure that the gasket is seated at the bottom of the hub.
5. Remove the four hub setscrews.
6. Place the 32003519 O-ring over the actuator hub and position the O-ring so that it is flush with the hub bearing.
7. Replace the four hub setscrews.
8. Apply the 32003509 RTV sealant to the openings on the four corners of the actuator case facing and around the mounting bracket, as shown in Fig. 4.
9. Remove gaskets B, C and D from the 32002915 Gasket Set and position in the actuator case, as shown in Fig. 3.
10. Replace the actuator cover and tighten the cover screw.

Visually check the actuator for complete weather sealing at all gasket and sealant locations.

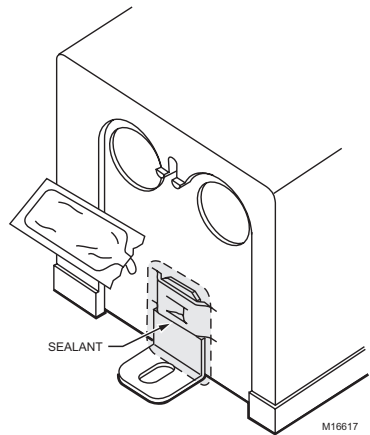




**Fig. 2. Applying gaskets and sealant to hub side of ML7999 Actuator.**



**Fig. 3. Applying gaskets to ML7999 Actuator cover.**



**Fig. 4. Applying sealant around actuator mounting bracket.**

**Automation and Control Solutions**

Honeywell International Inc.  
1985 Douglas Drive North  
Golden Valley, MN 55422

Honeywell Limited-Honeywell Limitée  
35 Dynamic Drive  
Scarborough, Ontario  
M1V 4Z9

