

MS4120F, MS8120F Fast-Acting, Two-Position Actuators FOR FIRE/SMOKE CONTROL APPLICATIONS



APPLICATION

The MS4120F, MS8120F Fast-Acting, Two-Position Actuators are spring return direct coupled actuators (DCA) for on/off damper control designed to operate reliably in smoke control systems requiring Underwriter's Laboratories Inc. UL555S ratings up to 350°F. The actuator accepts an on/off signal from a single-pole, single-throw (spst) controller. Reversible mounting allows actuator to be used for either clockwise (cw) or counterclockwise (ccw) spring rotation.

SPECIFICATIONS

Auxiliary Switches (SPST):

- Ratings (maximum load): 250 Vac, 5A resistive, 3A inductive.
- Settings (fixed): 7° nominal stroke, 85° nominal stroke.

Dimensions:

- See Fig. 1.

Device Weight:

- 7 lb (3.2 kg).

Temperature Ratings:

- Ambient: -40°F to 130°F (-40°C to 55°C).
- Shipping and Storage: -40°F to 140°F (-40°C to 60°C).

IMPORTANT

The actuator is designed to meet UL555S standards at 350°F (176°C). The actuator must be tested with the damper to achieve this rating.

Humidity Ratings:

- 5% to 95% RH noncondensing.

Stroke:

- 95° ± 3°, mechanically limited.

Minimum Damper Shaft Length:

- 1 in. (25 mm); 3-1/4 (83 mm) recommended.

Mounting:

- Self-centering shaft adapter.
 - Round Damper Shafts: 0.5 to 1.06 in.
 - Square Damper Shafts: 1/2 to 3/4 in.
- Actuator can be mounted with shaft in any position.

IMPORTANT

3/4 in. or greater shaft diameter recommended.

Torque Rating (at rated voltage):

- Typical Holding (minimum at 350°F): 175 lb-in. (20 N•m).
- Spring Return (minimum at 350°F): 175 lb-in. (20 N•m).
- Stall Maximum (fully open at 75°F): 425 lb-in. (48.0 N•m).
- 350°F Minimum Driving: 175 lb-in. (20 N•m).

Design Life (at Rated Voltage):

- 30,000 full stroke cycles.

SPECIFICATION DATA

FEATURES

- 175 lb-in. (20 N•m) minimum driving torque at 350°F (176°C).
- Reversible mounting facilitates use in either clockwise (cw) or counterclockwise (ccw) spring rotation.
- Integral spring return ensures level of return torque.
- Stainless steel internal spring.
- Fifteen-second spring return timing.
- No special cycling required during long-term holding.
- No audible noise during holding.
- Patent pending design eliminates need for limit switches to reduce power consumption.
- Models available for 24 and 120 Vac applications.
- Ninety-five degree angle of rotation.
- Actuator holds rated torque at reduced power level.
- Die-cast aluminum housing.
- Housing design allows flush mounting to damper.
- Self-centering shaft adapter (SCSA), patent pending.
- High temperature Teflon® lead wires.
- Designed to operate reliably in smoke control systems requiring Underwriter's Laboratories Inc. UL555S ratings up to 350°F.
- Models available with integral high temperature (350°F) SPST position-indicating switches (7°, 85° stroke).

Electrical Ratings:

- Power Input:
 - MS4120F: 120 Vac ±10%, 60 Hz.
 - MS8120F: 24 Vac +20%, -10%, 50/60 Hz (Class 2).
- Power Consumption:
 - MS4120F: Driving: 0.35A, 35W. Holding: 0.15A, 10W.
 - MS8120F: Driving: 45 VA. Holding: 10 VA.

Electrical Connections:

- Lead Wires (both Power and End Switch): 1m Teflon wire.
- Two integral 3/8 in. flexible conduit connections.

Timing (At Rated Torque and Voltage):

- Drive Open: 15 seconds typical.
- Spring Close: 15 seconds typical.

Controller Type:

- MS4120F: Line voltage (120 Vac), 2-position, spst (Series 40).
- MS8120F: Low voltage (24 Vac), 2-position, spst (Series 80).

Noise Rating at 1m (Maximum):

- Driving or Spring Return: 70 dBA.
- Holding: 20 dBA (no audible noise).



Models:

Table 1. Actuator Selection (MS Series).

| | |
|-----------|--|
| M | Electrical Motor |
| S | Fail Safe Function (Spring Return) |
| 41 | 120 Vac 2-position Control; Reversible Mount Spring Return |
| 81 | 24 Vac 2-position Control; Reversible Mount Spring Return |
| 20 | 175 lb-in. (20 N•m) |
| F | Fire and Smoke (US) |
| 1 | No Feedback |
| 0 | No Auxiliary Switches |
| 2 | Two Auxiliary Switches |
| XX | System Controlled Numbers |

| | | | | | | | |
|----------|----------|-----------|-----------|----------|----------|----------|-----------|
| M | S | 41 | 20 | F | 1 | 2 | XX |
|----------|----------|-----------|-----------|----------|----------|----------|-----------|

^a Internal SPST switches are designed to pass UL555S requirements (at 350°F).

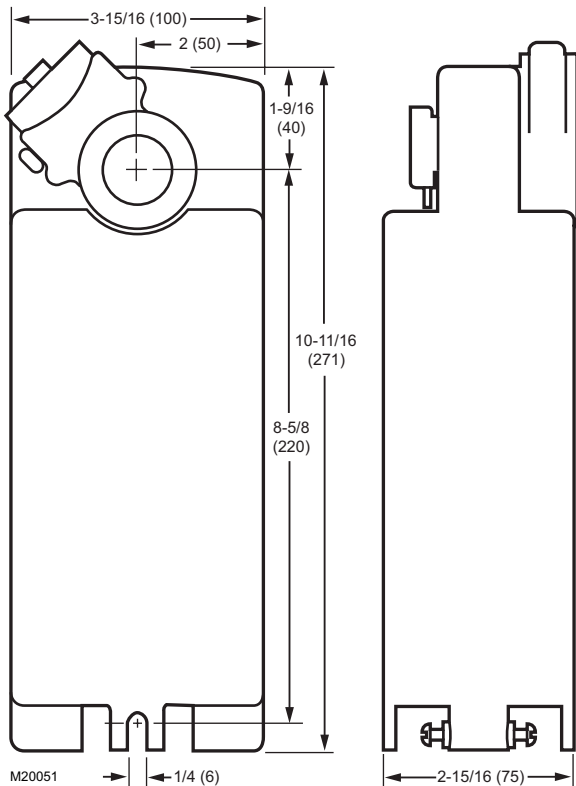

Fig. 1. Dimensional drawing of actuator in in. (mm).

TYPICAL SPECIFICATION

Power-fail return actuator shall be direct coupled type that requires neither crankarm nor linkage and be capable of direct mounting to a jackshaft of up to one inch diameter. The actuator shall connect to the shaft using a removable output hub with a self-centering shaft coupling that provides concentric mounting.

Actuators shall have integral conduit connections and Teflon leadwires for both power and end switch connections.

The actuator must provide two-position control. Upon power failure the hub must return by a string-type mechanism internal to the actuator. The actuator design must be for use in either clockwise or counterclockwise fail-safe operation.

Actuators shall have a minimum performance of 30,000 full stroke cycles documented in the product literature. Actuators shall be UL and cUL listed, manufactured under ISO 9001 International Quality Control Standards.

Cycling Requirements:

- Prolonged holding-period (1 year) testing of these actuators has been performed with no spring return failures. The actuator and the internal spring are designed to require no special cycling during long-term holding.
- Honeywell recommends following all local, state and national codes for periodic testing of the entire smoke control system. Refer to National Fire Protection Association (NFPA) National Fire Codes®: NFPA90A, NFPA92A and NFPA92B for your application.
- NFPA recommends periodic examination of each fire/smoke damper (semi-annually or annually) to ensure proper performance.

Environmental Protection Ratings:

- NEMA2 and IP54 when mounted on a horizontal shaft.

Approvals:

- See Table 2.

Accessories (not supplied with actuator):

- 205649 Mounting Bracket (not supplied with actuator).

Table 2. Approvals.

| | MS4120F | MS8120F |
|---|---------|---------|
| UL/cUL | X | X |
| UL873 Plenum Rating, File No. E4436; Guide No. XAPX. ^a | X | X |
| CE | | X |
| C-TICK | | X |

^a Plenum applications require that conductors be enclosed in conduit (see Wiring section for conduit details).

Teflon® is a registered trademark of the E.I. du Pont de Nemours and Company.

National Fire Codes® is a registered trademark of the National Fire Protection Association (NFPA).

Automation and Control Solutions

Honeywell International Inc.
1985 Douglas Drive North
Golden Valley, MN 55422
customer.honeywell.com

Honeywell Limited-Honeywell Limitée
35 Dynamic Drive
Scarborough, Ontario M1V 4Z9

Honeywell