

## VFF1, VFF2, VFF3, VFF6 Resilient Seat Butterfly Valves with Flanged Connections

### PRODUCT DATA



### APPLICATION

The VFF1/VFF2 two-way and VFF3/VFF6 three-way flanged, resilient-seated butterfly valve assemblies provide compact, two-position and modulating control of hot water and chilled water-glycol solutions in heating, ventilating, and air conditioning (HVAC) systems. Valves sizes range from 2 to 20 inches. Valves with full-cut disks provide up to 175 psi close-off.

These valve assemblies are shipped with factory-mounted electric or pneumatic actuators with a variety of control signal inputs. VFF2 two-way bodies are also available as non-actuated models with either lever or gear manual operators for use as shut-off and balancing valves.

Spring-return actuators are available in normally open (VFF1) or normally closed (VFF2) two-way configurations.

Three-way valve assemblies consist of a pair of 2-way valve bodies with a common actuator mounted on a standard, iron pipe Tee. Either A-B-AB porting (VFF3) or A-AB-B porting (VFF6) is available. The A-port is factory-set to the normally closed position, but the linkage assemblies are field-adjustable to seven other configurations.

### FEATURES

#### All Models

- Sizes from 2 to 20 inches with ANSI Class 125/150 lug pipe connections.
- Bi-directional flow.
- Modified equal percentages flow characteristic.
- Extended neck for 2 inches of pipe insulation.
- Nylon 11-coated, cast iron disks for corrosion resistance, reduced friction and use of lower-torque actuators with larger valves body sizes.
- Cast iron valve body polyester-coated for weather, chemical, ultra-violet, abrasion, and impact protection.
- Stainless steel valve stem with close-tolerance internal double-D disk connection with no points for corrosion access.
- Peroxide-cured EPDM resilient valve seat doubles as flange gasket.
- Bubble-tight seat leakage at rated close-off.
- Close-off rating of 175 psid in sizes 2 in. to 12 in. with full-cut disks.
- Close-off rating of 150 psid in sizes 14 in. to 20 in. with full-cut disks.
- 250 psi end-of-line close-off pressure rating with non-automated valves.
- 50 psid close-off rating, lower operating torque with undercut disks.
- ISO 5211 actuator mounting flange.
- Available with four, factory-installed electric actuation interfaces in 24V and 120V power: 2-position spring return, Floating (“tri-state”), Modulating (2-10 Vdc), Modulating/ Floating Spring Return.
- Actuators available in NEMA 2 (general purpose), NEMA 4X (watertight/corrosion-resistant), and NEMA 4 (watertight) enclosures.
- Anti-condensate heaters standard with NEMA 4X and NEMA 4 actuators.
- Declutchable override handwheel standard with NEMA 4X actuators.
- Non-declutchable, override handwheel standard with NEMA 4 actuators.

#### Contents

Application .....	1
Features .....	1
Specifications .....	2
Ordering Information .....	2
Installation .....	14
Operation and Checkout .....	19
Typical Specifications .....	20



- Available with six, factory-installed pneumatic actuation interfaces in low or high air pressure: 2-position spring return, 2-position bidirectional, proportional spring return, proportional bidirectional, positioner spring return, and positioner bidirectional.
- Available with three, factory-installed high pressure electro-pneumatic interfaces in spring return and bidirectional configurations: 24 Vac solenoid, 120 Vac solenoid, and modulating input, available position status indicator switches.

#### Two-Way Valves (VFF1/VFF2)

- Normally-open configuration (VFF1 spring return).
- Normally-closed configuration (VFF2 spring return).
- Non-automated valves available with choice of manual lever or gear operators.

#### Three-Way Valve Assemblies (VFF3/VFF6)

- Mixing or diverting control.
- Standard right-angle cast-iron pipe T.
- Globe valve A-B-AB flow pattern (side B port) through VFF3.
- Ball valve A-AB-B flow pattern (end B port) through VFF3.
- A-port configured to closed position at factory.
- Porting pattern field-configurable with valve linkage adjustment.

### Related Literature

- 63-9683 Quick Selection Guide
- 63-9271 Damper, Actuator, Valve catalog

## SPECIFICATIONS

**NOTE:** All specifications were accurate at time of publication. Honeywell reserves the right to improve or discontinue products without prior notification. To obtain the latest technical literature, please consult the ECC website at <http://customer.honeywell.com>.

**Models:** See Table 1

**Dimensions:** See Figures 1-11

**Mounting:** Bolt holes conform to ANSI B16.1, Class 125/150. See Table 1 for models.

#### Body Style:

Two-way lugged butterfly valve, straight-through flow, full or undercut disk.

Three-way ball valve, A-B-AB or A-AB-B flow pattern, full or undercut disks.

ANSI 125/150 flanged connections. See Fig. 12.

**Operating Torque:** See Fig. 14

**Body Size:** 2 in. to 20 in.

#### Flow Characteristics:

Modified equal percentage up to 60° stem rotation. (See Fig. 13.)

#### Body Static Pressure Rating (maximum):

Automated valves: 175 psid (1206 kPa) at 250 °F (121 °C).

Manual valves, 2 in. to 20 in.: 250 psid (1725 kPa) at 250 °F (121 °C).

**Operating (seating/unseating) Torque:** See Figure 14

**Close-Off Pressure Rating (maximum differential):**

#### Automated Valves

##### 2 in. to 12 in.:

175 psid (1206 kPa) at 250 °F (121 °C).

End-of-line service without downstream flange:

75 psid (517 kPa).

##### 14 in. to 20 in.:

150 psid (1034 kPa) at 250 °F (121 °C).

End-of-line service without downstream flange:

50 psid (345 kPa).

High pressure, bi-directional pneumatic: 175 psid (1206 kPa) at 250 °F (121 °C).

##### 4 in. to 20 in., undercut disk: 50 psid (345 kPa) at 250 °F (121 °C).

**NOTE:** undercut models are not suitable for dead end service without mating downstream flange.

#### Manual Valves (oversize disc)

**2 in. to 20 in.:** 250 psid (1725 kPa) at 250 °F (121 °C) without downstream flange.

#### Controlled Media:

Water or Glycol solutions up to 50% concentration.

Not suitable for combustible gases or steam.

**Temperature range:** -40 °F to 250 °F (-40 °C to 121 °C).

#### Velocity limits for on-off service:

Fluids: 30 fps (9 m/s),

Gases: 175 fps (54 m/s)

#### Materials:

Body: Cast iron, polyester-coated ASTM A126 Class B.

Disk: Ductile iron, Nylon™ 11 coated, ASTM A536 Grade 65-45-12.

Stem: 416 Stainless steel, ASTM 582 Type 416.

Seat: EPDM, food-grade.

Stem Seals: heavy duty acetal bushing, double-U cup seal, and thrust washer.

#### Approvals/Standards:

Close-off: Bubble-tight design.

Honeywell NEMA 2 Direct-Coupled Actuators: UL C/US; UL873 Plenum Rating, File N. E4436; Guide No. XAPX; CE; C-TICK.

Industrial-grade NEMA 4X Electric/Electronic Actuators: UL Listed, CSA Certified, CE.

Industrial-grade electro-pneumatic solenoids and transducers: UL Listed, CSA Certified, CE.

CRN: special order. Contact Honeywell product management.

RoHS/WEEE Compliance: not applicable

#### Actuator Ambient Temperature Ratings:

Electric actuators: See Table 2

Low pressure pneumatic actuators: -20 °F to 150 °F (-29 °C to 66 °C)

High pressure pneumatic actuators: -40 °F to 200 °F (-40 °C to 95 °C).

#### Accessories:

VFF50-0400 auxiliary switch kit for high pressure pneumatic actuators

## ORDERING INFORMATION

When purchasing replacement and modernization products from your TRADELINE® wholesaler or distributor, refer to the TRADELINE® Catalog or price sheets for complete ordering number. If you have additional questions, need further information, or would like to comment on our products or services, please write or phone:

1. Your local Honeywell Environmental and Combustion Controls Sales Office (check white pages of your phone directory).
2. Honeywell Customer Care  
1985 Douglas Drive North  
Minneapolis, Minnesota 55422-4386
3. <http://customer.honeywell.com> or <http://customer.honeywell.ca>

International Sales and Service Offices in all principal cities of the world. Manufacturing in Belgium, Canada, China, Czech Republic, Germany, Hungary, Italy, Mexico, Netherlands, United Kingdom, and United States.

**Table 1. VFF resilient seat butterfly valves model selection**

Butterfly Valves	Fitting	Body Pattern	Size	Disk Size (close-off)	Pressure Rating	Valve Trim	Actuator Secondary Spec.	Actuator Primary	Description	Actuator Type														
VF	Butterfly Valve, resilient seat																							
	F	Flanged fitting																						
		1	2-way (spring return normally open), pneumatic only																					
			2	2-way (non-spring return or electric spring return DCA, factory set to normally closed, and field-convertible to normally open.)																				
				3	3-way A-B-AB (mixing/diverting)																			
					6	3-way A-AB-B (diverting/mixing)																		
						F	2 inch (DN50)																	
							G	2-1/2 inch (DN65)																
		H						3 inch (DN80)																
			J					4 inch (DN100)																
				K				5 inch (DN125)																
					L			6 inch (DN150)																
								M	8 inch (DN200)															
									N	10 inch (DN250)														
										P	12 inch (DN300)													
											R	14 inch (DN350)												
												S	16 inch (DN400)											
													T	18 inch (DN450)										
														U	20 inch (DN500)									
															V	Undercut disk (lower actuator torque; 50 psid close-off)								
						W										Full diameter disk (high close-off)								
							1								Maximum 175 psi close-off pressure									
		2				Maximum 250 psi close-off pressure (manual valves only)																		
			Y			Nylon-coated disk, EPDM seat																		
		2		NEMA 2 actuator housing (Honeywell DCA) See fig. 2 and 3 for tandem mounting dimensions.											Electric									
				4	NEMA 4 actuator housing with manual operator and heater																			
					X	NEMA 4X actuator housing with manual operator and heater																		
		8		Spring Range 8-13 psi for 20 psi pneumatic actuator											Pneumatic									
				C	24 Vac solenoid for 80 psi pneumatic actuator																			
					D	Electro-pneumatic positioner for 80 psi actuator																		
						E	120 Vac solenoid for 80 psi pneumatic actuator																	
							P	Pneumatic positioner for modulating applications																
								X	Standard, two-position control only															
L		Lever operator for dead end service										Manual												
	G	Geared operator for dead end service																						
A		Floating actuator										Electric												
	B	Modulating actuator																						
		C	Two-position 24 Vac spring return actuator																					
			D	Modulating spring return actuator																				
				E	Two-position 120 Vac spring return actuator																			
P					Pneumatic actuator, spring return 20 psi										Pneumatic									
	R				Pneumatic actuator, double-acting 80 psi (140 psi maximum)																			
		S			Pneumatic actuator, spring return 80 psi (140 psi maximum)																			
X	Valve body only, for dead end service										Manual													

VF F 2 J V 1 Y 2 D Example: 2-way, 4 inch flanged resilient-seat butterfly valve, undercut disk (50 psid close-off) modulating/floating control, spring return normally closed.

VFF1, VFF2, VFF3, VFF6 RESILIENT SEAT BUTTERFLY VALVES WITH FLANGED CONNECTIONS

Note: This table is intended to explain the significance of the VFF butterfly valve part numbering system, and is not a product configuration tool. Only part numbers printed in Honeywell price books may be ordered. Please contact Product Marketing for information and feasibility of custom configurations. Refer to figures 2 and 3 for tandem DCA configurations.

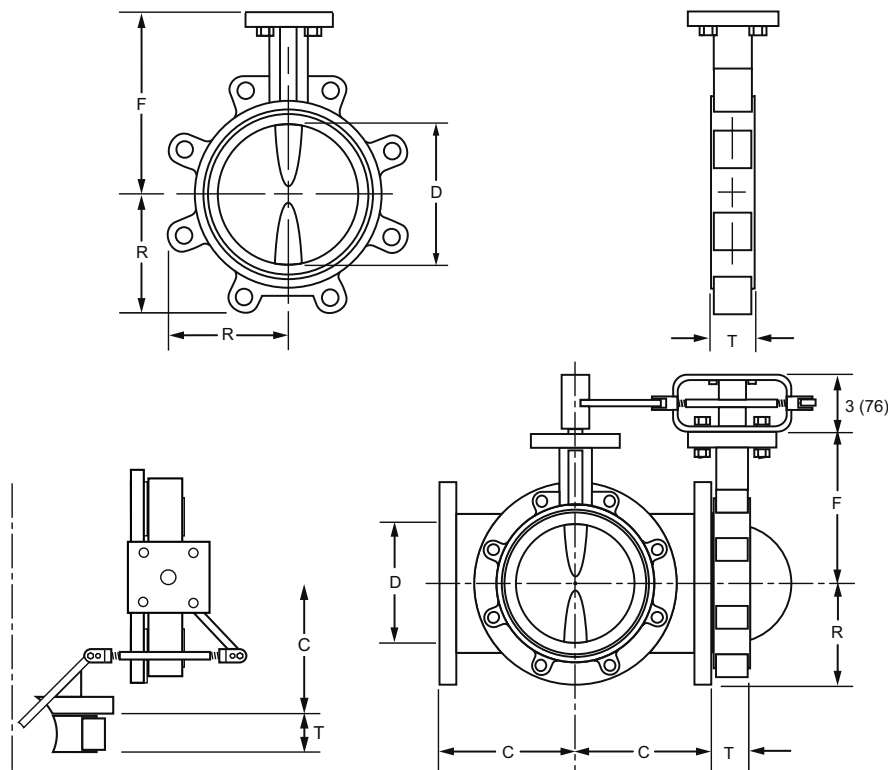

Pipe Size in. [mm]	Model No. 2-way / 3-way	Cv [kvs]		Close-off Pressure, Operating Torque, lb-in. [Nm]						Flanged Valve Body Dimensions, inches [mm]								
		@ 60°	@ 90°	Full Cut Disk (...W1Y...)			Under Cut Disk (...V1Y...)			D	R	F	T	C (3-way)	Flange Bolts			
				Close-off	2-way	3-way	Close-off	2-way	3-way	I.D.	Radius	Neck	Thickness	Face-C/L	No.	C/L Dia	Thread	
2" [DN50]	1, 2... F... 3, 6... F...	61 [53]	144 [125]	175 psid [1206 kPa]	126 [14]	151 [17]	Only high close-off (full cut disk) models available in these body sizes			2 [51]	2-1/4 [58]	5-1/2 [140]	1-5/8 [41]	4-1/2 [114]	4	4-3/4 [121]	5/8-11	
2-1/2" [DN65]	1, 2... G... 3, 6... G...	107 [93]	282 [244]		150 [17]	180 [20]	2-1/2 [64]	2-9/16 [65]	6 [152]	1-3/4 [44]	5 [127]	5-1/2 [140]	6 [140]	5-1/2 [140]		6 [140]		5-1/2 [140]
3" [DN80]	1, 2... H... 3, 6... H...	154 [133]	461 [399]		180 [20]	216 [24]	3 [76]	2-3/4 [71]	6-1/4 [159]	5-1/2 [140]	5-1/2 [140]	6-1/4 [159]	6-1/4 [159]	6-1/4 [159]		6-1/4 [159]		6-1/4 [159]
4" [DN100]	1, 2... J... 3, 6... J...	274 [237]	841 [727]		372 [42]	446 [50]	4 [102]	4-1/16 [104]	7 [178]	2 [51]	6-1/2 [165]	6-1/2 [165]	6-1/2 [165]	6-1/2 [165]		6-1/2 [165]		6-1/2 [165]
5" [DN125]	1, 2... K... 3, 6... K...	428 [370]	1376 [1190]		468 [53]	562 [64]	5 [127]	4-5/8 [117]	7-1/2 [191]	2-1/8 [54]	7-1/2 [191]	7-1/2 [191]	7-1/2 [191]	7-1/2 [191]	7-1/2 [191]	7-1/2 [191]		
6" [DN150]	1, 2... L... 3, 6... L...	567 [490]	1850 [1600]		564 [64]	677 [77]	6 [152]	5 [129]	8 [203]	8 [203]	8 [203]	8 [203]	8 [203]	8 [203]	8 [203]	8 [203]		
8" [DN200]	1, 2... M... 3, 6... M...	1081 [935]	3316 [2868]		1224 [138]	1469 [166]	8 [203]	6 [154]	9-1/2 [241]	9 [229]	9-1/2 [241]	9-1/2 [241]	9-1/2 [241]	9-1/2 [241]	9-1/2 [241]	9-1/2 [241]		
10" [DN250]	1, 2... N... 3, 6... N...	1710 [1479]	5430 [4697]		2637 [298]	3164 [358]	10 [254]	7-3/4 [195]	10-3/4 [273]	6 [154]	10-3/4 [273]	10-3/4 [273]	10-3/4 [273]	10-3/4 [273]	10-3/4 [273]	10-3/4 [273]		
12" [DN300]	1, 2... P... 3, 6... P...	2563 [2217]	8077 [6987]		4132 [467]	4958 [560]	12 [305]	9 [229]	12-1/4 [311]	12 [305]	12-1/4 [311]	12-1/4 [311]	12-1/4 [311]	12-1/4 [311]	12-1/4 [311]	12-1/4 [311]		
14" [DN350]	1, 2... R... 3, 6... R...	3384 [2927]	10538 [9115]		5864 [663]	7037 [796]	14 [356]	9-15/16 [252]	13-5/8 [346]	14 [356]	13-5/8 [346]	13-5/8 [346]	13-5/8 [346]	13-5/8 [346]	13-5/8 [346]	13-5/8 [346]		
16" [DN400]	1, 2... S... 3, 6... S...	4483 [3878]	13966 [12081]	8182 [924]	9818 [1109]	16 [406]	11-1/4 [287]	14-3/4 [375]	15 [381]	14-3/4 [375]	14-3/4 [375]	14-3/4 [375]	14-3/4 [375]	14-3/4 [375]	14-3/4 [375]			
18" [DN450]	1, 2... T... 3, 6... T...	5736 [4962]	17214 [14890]	10819 [1222]	12983 [1466]	18 [457]	12-3/16 [309]	16 [406]	16 [406]	16-1/2 [419]	16-1/2 [419]	16-1/2 [419]	16-1/2 [419]	16-1/2 [419]	16-1/2 [419]			
20" [DN500]	1, 2... U... 3, 6... U...	7144 [6180]	22339 [19323]	14091 [1592]	16909 [1910]	20 [508]	14 [356]	17-1/4 [438]	18 [438]	17-1/4 [438]	17-1/4 [438]	17-1/4 [438]	17-1/4 [438]	17-1/4 [438]	17-1/4 [438]			

M31137

Fig. 1. VFF1, VFF2, VFF3 & VFF6 butterfly valve body dimensions

VFF1, VFF2, VFF3, VFF6 RESILIENT SEAT BUTTERFLY VALVES WITH FLANGED CONNECTIONS

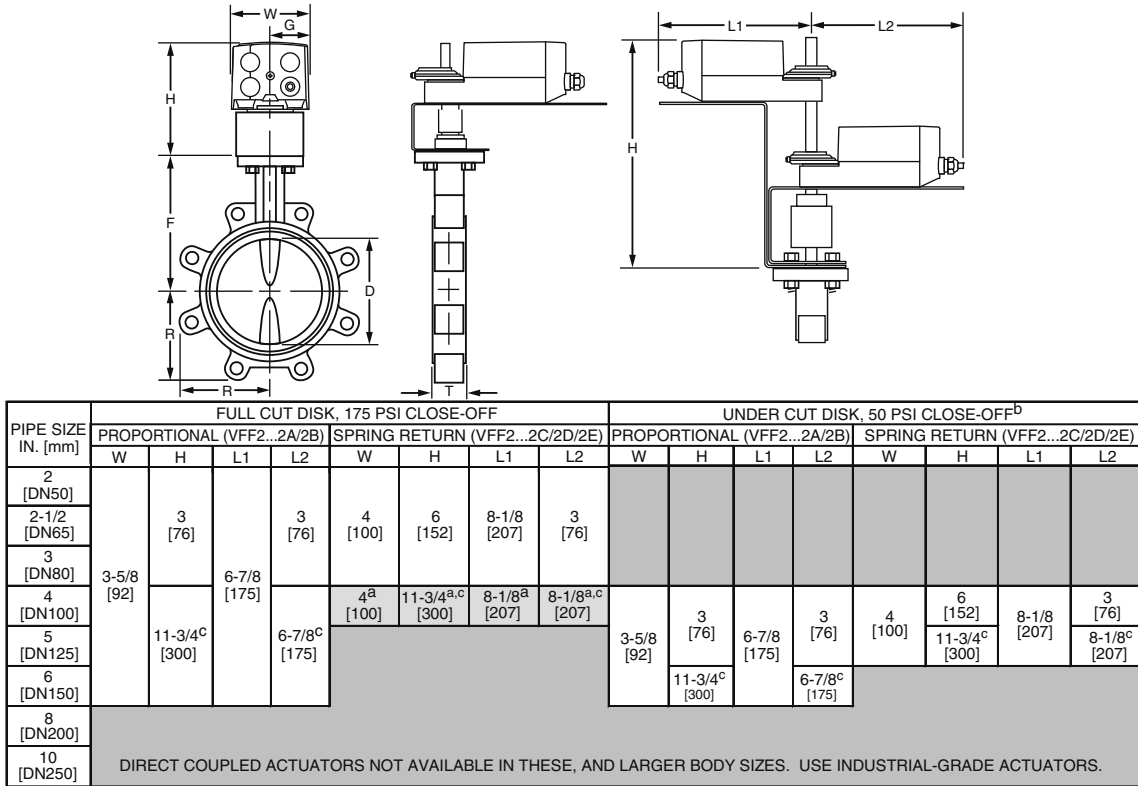

<sup>a</sup> CHILLED WATER APPLICATION ONLY.  
<sup>b</sup> NOTE: VALVE SIZES 2 TO 3 INCHES HAVE 175 PSI [1206 KPA] CLOSE-OFF AND ARE AVAILABLE ONLY WITH FULL CUT DISKS.  
<sup>c</sup> DIMENSION WITH TANDEM DIRECT-COUPLED ACTUATORS.

M31260A

Fig. 2. 2-Way VFF dimensions with NEMA 2 (Honeywell DCA) actuators Tandem Actuator orientation

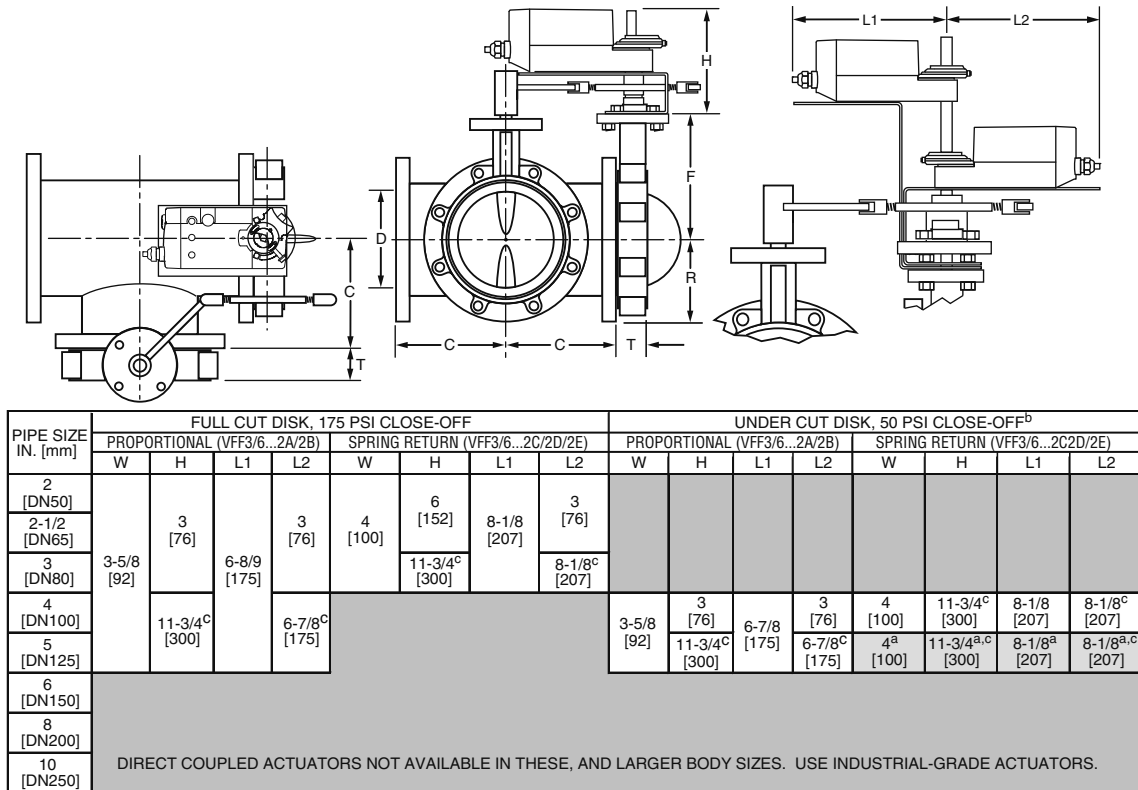

<sup>a</sup> CHILLED WATER APPLICATION ONLY.  
<sup>b</sup> NOTE: VALVE SIZES 2 TO 3 INCHES HAVE 175 PSI [1206 KPA] CLOSE-OFF AND ARE AVAILABLE ONLY WITH FULL CUT DISKS.  
<sup>c</sup> DIMENSION WITH TANDEM DIRECT-COUPLED ACTUATORS.

M31261A

Fig. 3. 3-Way VFF dimensions with NEMA 2 (Honeywell DCA) actuators Tandem Actuator orientation

VFF1, VFF2, VFF3, VFF6 RESILIENT SEAT BUTTERFLY VALVES WITH FLANGED CONNECTIONS

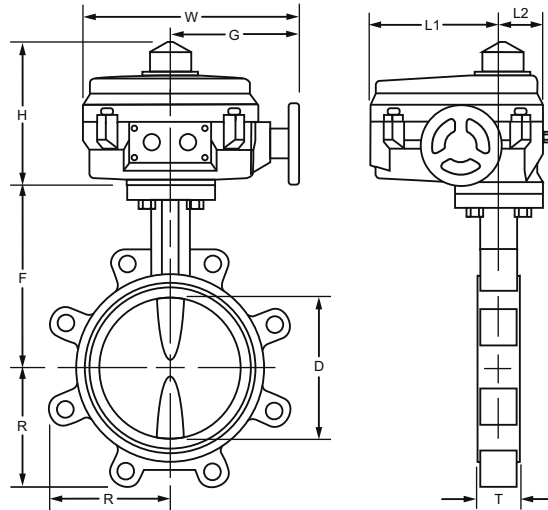

PIPE SIZE IN. [mm]	FULL CUT DISK, HIGH CLOSE-OFF* NEMA 4X (VFF2_W1YXA/B)					UNDER CUT DISK, 50 PSI CLOSE-OFF** NEMA 4X (VFF2_V1YXA/B)				
	W	H1	L1	L2	G	W	H1	L1	L2	G
2 [DN50]										
2-1/2 [DN65]	7-1/2 [191]	6-3/4 [170]	5-1/2 [141]	2 [51]	5-3/4 [147]					
3 [DN80]										
4 [DN100]						7-1/2 [191]	6-3/4 [170]	5-1/2 [141]	2 [51]	5-3/4 [147]
5 [DN125]										
6 [DN150]	10-1/8 [257]	8-1/8 [206]	7-3/8 [188]	2-3/4 [68]	7-3/4 [198]					
8 [DN200]						10-1/8 [257]	8-1/8 [206]	7-3/8 [188]	2-3/4 [68]	7-3/4 [198]
10 [DN250]										
12 [DN300]	12-1/8 [307]	8-3/4 [224]	8-7/8 [226]	3-1/4 [81]	9-1/2 [241]					
14 [DN350]										
16 [DN400]	NEMA 4 (VFF2_W1Y4A/4B)					12-1/8 [307]	8-3/4 [224]	8-7/8 [226]	3-1/4 [81]	9-1/2 [241]
18 [DN450]	8-1/2 [217]	16 [406]	8-3/4 [221]	4-1/2 [115]	12-1/2 [320]					
20 [DN500]						NEMA 4 (VFF2_V1Y4A/4B)				
						8-1/2 [217]	16 [406]	8-3/4 [221]	4-1/2 [115]	12-1/2 [320]

\* 175 PSI [1206 KPA] CLOSE-OFF UP TO 12 INCHES [DN 300], 150 PSI [1034 KPA] OTHERWISE

\*\*NOTE: VALVE SIZES 2 TO 3 INCHES HAVE 175 PSI [1206 KPA] CLOSE-OFF AND ARE AVAILABLE ONLY WITH FULL CUT DISKS.

▲ NEMA 4X ACTUATORS ARE WATERPROOF AND CORROSION-RESISTANT.

M27011

Fig. 4. 2-Way VFF dimensions with NEMA 4/4X (industrial-grade) actuators

VFF1, VFF2, VFF3, VFF6 RESILIENT SEAT BUTTERFLY VALVES WITH FLANGED CONNECTIONS

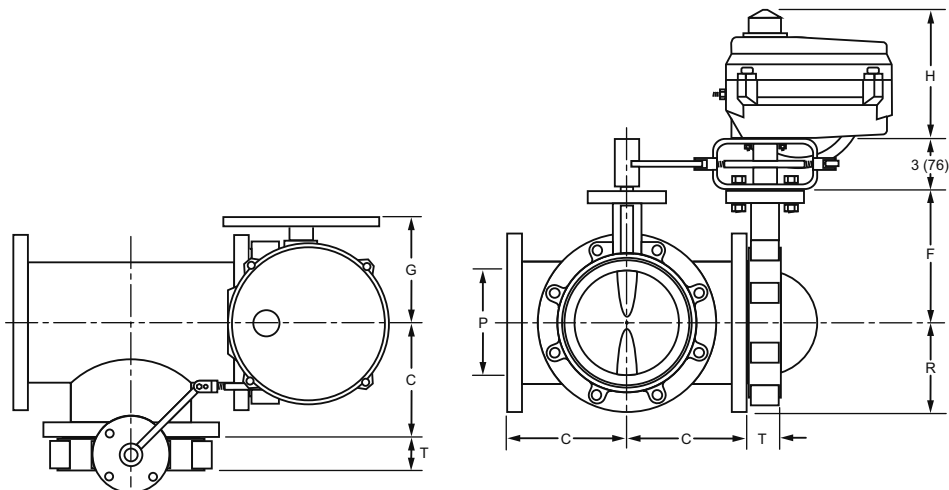

PIPE SIZE IN. [mm]	FULL CUT DISK, 175 PSI CLOSE-OFF NEMA 4X (VFF3/6_W1YXA/B)					UNDER CUT DISK, 50 PSI CLOSE-OFF** NEMA 4X (VFF3/6_V1YXA/B)				
	W	H	L1	L2	G	W	H	L1	L2	G
2 [DN50]										
2-1/2 [DN65]	7-1/2 [191]	6-3/4 [170]	5-1/2 [141]	2 [49]	5-3/4 [147]					
3 [DN80]										
4 [DN100]						7-1/2 [191]	6-3/4 [170]	5-1/2 [141]	2 [49]	5-3/4 [147]
5 [DN125]	10-1/8 [257]	8-1/8 [206]	7-3/8 [188]	2-3/4 [68]	7-3/4 [198]					
6 [DN150]										
8 [DN200]						10-1/8 [257]	8-1/8 [206]	7-3/8 [188]	2-3/4 [68]	7-3/4 [198]
10 [DN250]	12-1/8 [307]	8-3/4 [224]	8-7/8 [226]	3-1/4 [81]	9-1/2 [241]					
12 [DN300]										
14 [DN350]	NEMA 4 (VFF3/6_W1Y4A/4B)					12-1/8 [307]	8-3/4 [224]	8-7/8 [226]	3-1/4 [81]	9-1/2 [241]
16 [DN400]										
18 [DN450]	8-1/2 [217]	16 [406]	8-3/4 [221]	4-1/2 [115]	12-1/2 [320]	NEMA 4 (VFF3/6_V1Y4A/4B)				
20 [DN500]						8-1/2 [217]	16 [406]	8-3/4 [221]	4-1/2 [115]	12-1/2 [320]

\* 175 PSI [1206 KPA] CLOSE-OFF UP TO 12 INCHES [DN 300], 150 PSI [1034 KPA] OTHERWISE  
 \*\*NOTE: VALVE SIZES 2 TO 3 INCHES HAVE 175 PSI [1206 KPA] CLOSE-OFF AND ARE AVAILABLE ONLY WITH FULL CUT DISKS. M27020

Fig. 5. 3-Way VFF3, VFF6 dimensions with NEMA 4/4X (industrial-grade) actuators

VFF1, VFF2, VFF3, VFF6 RESILIENT SEAT BUTTERFLY VALVES WITH FLANGED CONNECTIONS

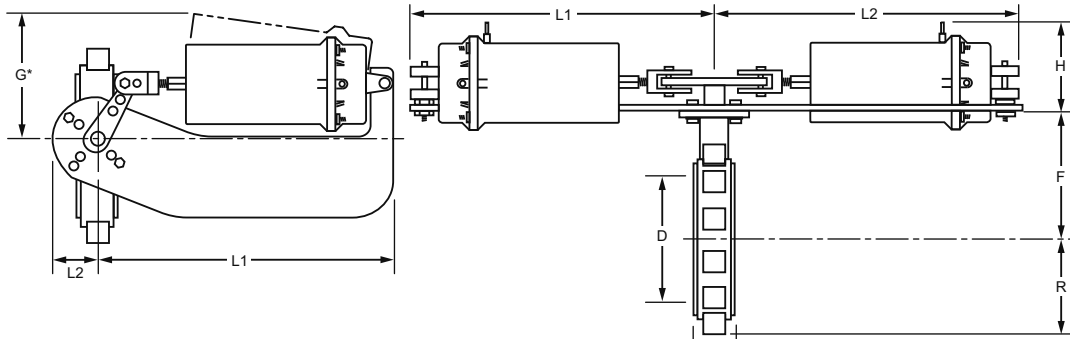

PIPE SIZE IN. [mm]	FULL CUT DISK, 175 PSI CLOSE-OFF (VFF1/2_W1Y8P/PP)					UNDER CUT DISK, 50 PSI CLOSE-OFF <sup>b</sup> (VFF1/2_V1Y8P/PP)				
	G	H	HP	L1	L2	G	H	HP	L1	L2 <sup>a</sup>
2 [DN50]	5-5/8 [144]	3-1/8 [79]	6-1/4 [160]	16 [406]	3 [76]					
2-1/2 [DN65]										
3 [DN80]										
4 [DN100]	7-1/4 [186]	6-7/8 [175]	10 [254]	20 [506]	3 [76]	5-5/8 [144]	3-1/8 [79]	6-1/4 [160]	16 [406]	
5 [DN125]	9 [227]		10-1/8 [257]	22-3/4 [578]		7-1/4 [186]	10 [254]	20 [506]		
6 [DN150]						9 [227]	6-7/8 [175]	10-1/8 [257]	22-3/4 [578]	22-3/4 <sup>c</sup> [578]
8 [DN200]						9 [227]	6-7/8 [175]	10-1/8 [257]	22-3/4 [578]	22-3/4 <sup>c</sup> [578]
10 [DN250]	LOW PRESSURE ACTUATORS NOT AVAILABLE IN THESE, AND LARGER BODY SIZES.									
12 [DN300]	LOW PRESSURE ACTUATORS NOT AVAILABLE IN THESE, AND LARGER BODY SIZES.									

<sup>a</sup> VALVE SIZES 2 TO 3 INCHES ARE AVAILABLE ONLY WITH FULL CUT DISKS.  
<sup>b</sup> VALVE STROKE IS LIMITED TO 70 DEGREES.  
<sup>c</sup> DIMENSION WITH TANDEM ACTUATORS.

M31262

Fig. 6. 2-way VFF1, VFF2 dimensions with 20 psi (low pressure) spring return pneumatic actuators

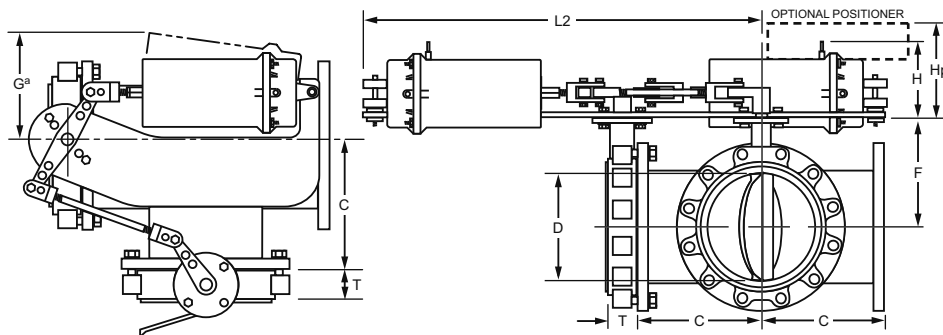

PIPE SIZE IN. [mm]	FULL CUT DISK, 175 PSI CLOSE-OFF (VFF3_W1Y8P/PP)					UNDER CUT DISK, 50 PSI CLOSE-OFF <sup>b</sup> (VFF3_V1Y8P/PP)				
	G	H	HP	L1	L2	G	H	HP	L2	
2 [DN50]	5-5/8 [144]	3 [79]	6-1/4 [160]	16 [406]	3 [76]					
2-1/2 [DN65]	7-1/4 [186]	6-7/8 [175]	10 [254]	20 [506]						
3 [DN80]	9 [227]		10-1/8 [257]	22-3/4 [578]		7-1/4 [186]	10 [254]	20 [506]		
4 [DN100]					9 [227]	6-7/8 [175]	10-1/8 [257]	22-3/4 [578]	22-3/4 <sup>c</sup> [578]	
5 [DN125]						9 [227]	6-7/8 [175]	10-1/8 [257]	22-3/4 [578]	22-3/4 <sup>c</sup> [578]
6 [DN150]	LOW PRESSURE ACTUATORS NOT AVAILABLE IN THESE, AND LARGER BODY SIZES.									
8 [DN200]	LOW PRESSURE ACTUATORS NOT AVAILABLE IN THESE, AND LARGER BODY SIZES.									
10 [DN250]	LOW PRESSURE ACTUATORS NOT AVAILABLE IN THESE, AND LARGER BODY SIZES.									
12 [DN300]	LOW PRESSURE ACTUATORS NOT AVAILABLE IN THESE, AND LARGER BODY SIZES.									

<sup>a</sup> NOTE: VALVE SIZES 2 TO 3 INCHES HAVE 175 PSI [1206 KPA] CLOSE-OFF ARE AVAILABLE ONLY WITH FULL CUT DISKS.  
<sup>b</sup> VALVE STROKE IS LIMITED TO 70 DEGREES.  
<sup>c</sup> DIMENSION WITH TANDEM ACTUATORS.

M31263

Fig. 7. 3-way VFF3 dimensions with 20 psi (low pressure) pneumatic actuators

VFF1, VFF2, VFF3, VFF6 RESILIENT SEAT BUTTERFLY VALVES WITH FLANGED CONNECTIONS

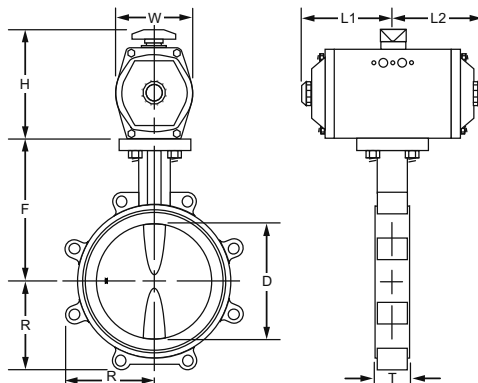

PIPE SIZE IN. [mm]	FULL CUT DISK, 175 PSI CLOSE-OFF (VFF2_W1YCR/DR/ER/PR/XR)					UNDER CUT DISK, 50 PSI CLOSE-OFF** (VFF2_V1YCR/DR/ER/PR/XR)				
	W	H	HP	L1	L2	W	H	HP	L1	L2
2 [DN50]										
2-1/2 [DN65]	2-3/4 [70]	4-1/4 [109]	10-1/4 [262]	3 [76]	3 [76]					
3 [DN80]										
4 [DN100]	3-5/8 [91]	5-2/8 [132]	11-2/8 [284]	4 [100]	4 [100]					
5 [DN125]										
6 [DN150]	4 [100]	5-1/2 [141]	11-1/2 [293]	4-1/2 [113]	4-1/2 [113]	3-5/8 [91]	5-1/4 [132]	11-1/4 [284]	4 [100]	4 [100]
8 [DN200]	4-3/4 [120]	6-7/8 [176]	12-7/8 [328]	6 [154]	6 [154]	4 [100]	5-1/2 [141]	11-1/2 [293]	4-1/2 [113]	4-1/2 [113]
10 [DN250]	5-3/8 [137]	7-3/4 [196]	13-3/4 [349]	6-1/8 [157]	6-1/8 [157]	4-3/4 [120]	6-7/8 [176]	12-7/8 [328]	6 [154]	6 [154]
12 [DN300]	6-3/4 [172]	9-3/8 [238]	15-3/8 [391]	7-3/4 [196]	7-3/4 [196]					
14 [DN350]										
16 [DN400]	8-7/8 [224]	11-5/8 [295]	17-5/8 [447]	9-1/2 [240]	9-1/2 [240]	6-3/4 [172]	9-3/8 [238]	15-3/8 [391]	7-3/4 [196]	7-3/4 [196]
18 [DN450]										
20 [DN500]	10-3/4 [273]	13-1/2 [342]	19-1/2 [495]	13-3/8 [339]	13-3/8 [339]	8-7/8 [224]	11-5/8 [295]	17-5/8 [447]	9-1/2 [240]	9-1/2 [240]

\*\*NOTE: VALVE SIZES 2 TO 5 INCHES ARE AVAILABLE ONLY WITH FULL CUT DISKS. M27013

Fig. 8. 2-way VFF2 dimensions with 80 psi (high pressure) pneumatic bi-directional actuators

Table 2. Electric Actuator Data

Actuator Style	Torque	Control Inputs	Fail Safe	Power Supply Voltage	Current/Power	Ambient Temp.	Stroke Timing	Valve Sizes	
								2-way	3-way
NEMA 2 (Honeywell DCA)	300 in.-lb. [34 Nm]	0-10/2-10 Vdc, Floating, SPDT, SPST	Non-spring return	24 Vac/dc, 50/60 Hz	8 VA	-5 to 140 F [-20 to 60 C]	90 sec.	2 in. to 5 in.	2 in. to 4 in.
	4 in. to 8 in. (tandem DCAs)							4 in. to 6 in. (tandem DCAs)	
	175 in.-lb. [20 Nm]		Spring return N.C/ N.O.	24 Vac, 50/60 Hz 120 Vac, 50/60 Hz	16 VA	-40 to 140 F [-40 to 60 C]		2 in. to 4 in. 4 in. to 5 in. (tandem DCAs)	2 in. to 2 1/2 in. 3 in. to 5 in. (tandem DCAs)
	NEMA 4X (Water-proof, Corrosion- Resistant)	500 in.-lb. [57 Nm]	4-20 mA dc, 0-10/2- 10 Vdc --- SP3T, SPDT	Non-Spring Return	120 Vac, 50/60 Hz	1.4 LRA <sup>1</sup>	-40 to 149 F [-40 to 65 C]	30 sec. modu- lating	2 in. to 5 in.
800 in.-lb. [90 Nm]		2.1 LRA <sup>1</sup>				5 in. to 10 in.			4 in. to 10 in.
1,200 in.-lb. [136 Nm]									
2,000 in.-lb. [136 Nm]									
3,000 in.-lb. [339 Nm]		3.0 LRA <sup>1</sup>				10 in. to 18 in.			10 in. to 16 in.
5,000 in.-lb. [565 Nm]									
NEMA 4 (Water-proof)	8,850 in.-lb. [1000 Nm]	4-20 mA dc, 2-10 Vdc --- SP3T, SPDT			3.2 FLA <sup>2</sup> 10.0 LRA <sup>1</sup>	-21 to 149 F [-30 to 65 C]	46 sec.	14 in. to 20 in.	16 in. to 20 in.
	13,275 in.-lb. [1500 Nm]				4.0 FLA <sup>2</sup> 10.0 LRA <sup>1</sup>				
E-P Solenoid (pneumatic)	up to 29,000 in.-lb. [3277 Nm]	SPST Series 80 SPST Series 40	N.S.R.; S.R. N.O., and N.C.	24 Vac, 50/60 Hz 120 Vac, 50/60 Hz	6.3 W	-13 to 140 F [-25 to 60 C]	1/4 sec. to 2-3/4 sec.	2 in. to 20 in.	

<sup>1</sup> Locked Rotor Amps

<sup>2</sup> Full Load Amps

VFF1, VFF2, VFF3, VFF6 RESILIENT SEAT BUTTERFLY VALVES WITH FLANGED CONNECTIONS

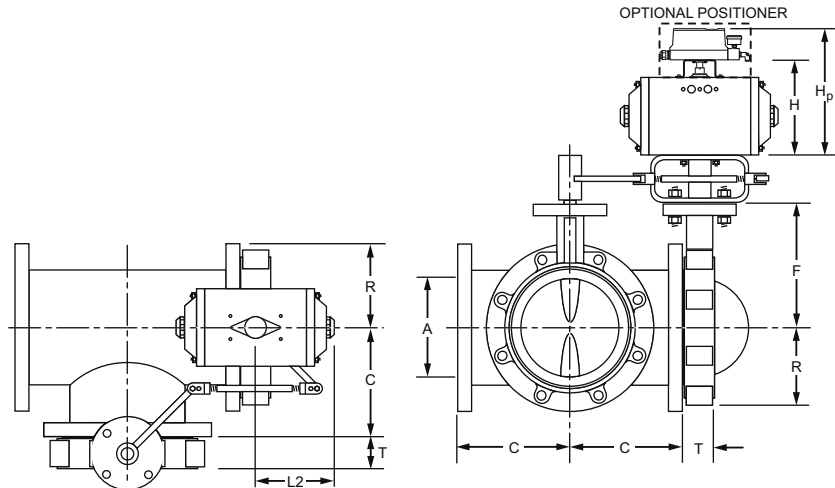

PIPE SIZE IN. [mm]	FULL CUT DISK, 175 PSI CLOSE-OFF (VFF3/6_W1YCR/DR/ER/PR/XR)					UNDER CUT DISK, 50 PSI CLOSE-OFF** (VFF3/6_V1YCR/DR/ER/PR/XR)				
	W	H	HP	L1	L2	W	H	HP	L1	L2
2 [DN50]	2-3/4 [70]	4-1/4 [109]	10-1/4 [262]	3 [76]	3 [76]					
2-1/2 [DN65]										
3 [DN80]	3-5/8 [91]	5-1/4 [132]	11-1/4 [284]	4 [100]	4 [100]					
4 [DN100]										
5 [DN125]	4-3/4 [120]	6-7/8 [176]	12-7/8 [328]	6 [154]	6 [154]	4 [100]	5-1/2 [141]	11-1/2 [293]	4-1/2 [113]	4-1/2 [113]
6 [DN150]										
8 [DN200]	5-3/8 [137]	7-3/4 [196]	13-3/4 [349]	6-1/8 [157]	6-1/8 [157]	4-3/4 [120]	6-7/8 [176]	12-7/8 [328]	6 [154]	6 [154]
10 [DN250]	6-3/4 [172]	9-3/8 [238]	15-3/8 [391]	7-3/4 [196]	7-3/4 [196]					
12 [DN300]	8-7/8 [224]	11-5/8 [295]	17-5/8 [447]	9-1/2 [240]	9-1/2 [240]	6-3/4 [172]	9-3/8 [238]	15-3/8 [391]	7-3/4 [196]	7-3/4 [196]
14 [DN350]										
16 [DN400]										
18 [DN450]	10-3/4 [273]	13-1/2 [342]	19-1/2 [495]	13-3/8 [339]	13-3/8 [339]	8-7/8 [224]	11-5/8 [295]	17-5/8 [447]	9-1/2 [240]	9-1/2 [240]
20 [DN500]										

\*\*NOTE: VALVE SIZES 2 TO 4 INCHES ARE AVAILABLE ONLY WITH FULL CUT DISKS.

M27022

Fig. 9. 3-way VFF3, VFF6 dimensions with 80 psi (high pressure) pneumatic bi-directional actuators

VFF1, VFF2, VFF3, VFF6 RESILIENT SEAT BUTTERFLY VALVES WITH FLANGED CONNECTIONS

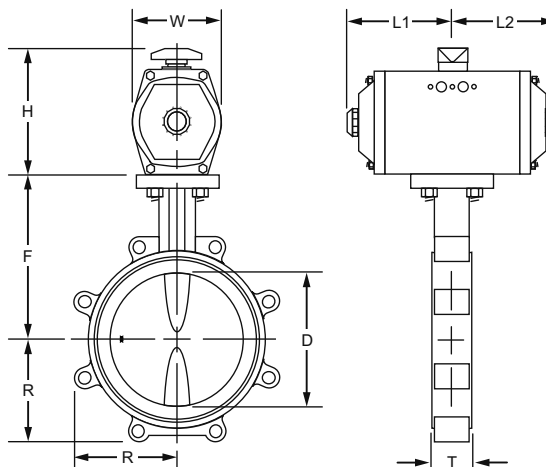

PIPE SIZE IN. [mm]	FULL CUT DISK, HIGH CLOSE-OFF*										UNDER CUT DISK, 50 PSI CLOSE-OFF**									
	N.O. (VFF1 V1YCS/DS/ES/PS/XS)					N.C. (VFF2 V1YCS/DS/ES/PS/XS)					N.O. (VFF1 V1YCS/DS/ES/PS/XS)					N.C. (VFF2 V1YCS/DS/ES/PS/XS)				
	W	H	HP	L1	L2	W	H	HP	L1	L2	W	H	HP	L1	L2	W	H	HP	L1	L2
2 [DN50]																				
2-1/2 [DN65]	3-5/8 [91]	5-1/4 [132]	11-1/4 [284]	4 [100]	4 [100]	3-5/8 [91]	5-1/4 [132]	11-1/4 [284]	4 [100]	4 [100]										
3 [DN80]																				
4 [DN100]	4 [100]	5-1/2 [141]	11-1/2 [293]	4-1/2 [113]	4-1/2 [113]	4 [100]	5-1/2 [141]	11-1/2 [293]	4-1/2 [113]	4-1/2 [113]	3-5/8 [91]	5-2/8 [132]	11-2/8 [284]	4 [100]	4 [100]	3-5/8 [91]	5-2/8 [132]	11-2/8 [284]	4 [100]	4 [100]
5 [DN125]	4-3/4 [120]	6-7/8 [176]	12-7/8 [328]	6 [154]	6 [154]	4-3/4 [120]	6-7/8 [176]	12-7/8 [328]	6 [154]	6 [154]	4 [100]	5-1/2 [141]	11-1/2 [293]	4-1/2 [113]	4-1/2 [113]	4 [100]	5-1/2 [141]	11-1/2 [293]	4-1/2 [113]	4-1/2 [113]
6 [DN150]																4-3/4 [120]	6-7/8 [176]	12-7/8 [328]	6 [154]	6 [154]
8 [DN200]	6-3/4 [172]	9-3/8 [238]	15-3/8 [391]	7-3/4 [196]	7-3/4 [196]	6-3/4 [172]	9-3/8 [238]	15-3/8 [391]	7-3/4 [196]	7-3/4 [196]	4-3/4 [120]	6-7/8 [176]	12-7/8 [328]	6 [154]	6 [154]	6-3/4 [172]	9-3/8 [238]	15-3/8 [391]	7-3/4 [196]	7-3/4 [196]
10 [DN250]	8-7/8 [224]	11-5/8 [295]	17-5/8 [447]	9-1/2 [240]	9-1/2 [240]						5-3/8 [137]	7-3/4 [196]	13-3/4 [349]	6-1/8 [157]	6-1/8 [157]	6-3/4 [172]	9-3/8 [238]	15-3/8 [391]	7-3/4 [196]	7-3/4 [196]
12 [DN300]						8-7/8 [224]	11-5/8 [295]	17-5/8 [447]	9-1/2 [240]	9-1/2 [240]	6-3/4 [172]	9-3/8 [238]	15-3/8 [391]	7-3/4 [196]	7-3/4 [196]					
14 [DN350]																				
16 [DN400]	10-3/4 [273]	13-1/2 [342]	19-1/2 [495]	13-3/8 [339]	13-3/8 [339]						8-7/8 [224]	11-5/8 [295]	17-5/8 [447]	9-1/2 [240]	9-1/2 [240]	8-7/8 [224]	11-5/8 [295]	17-5/8 [447]	9-1/2 [240]	9-1/2 [240]
18 [DN450]						10-3/4 [273]	13-1/2 [342]	19-1/2 [495]	13-3/8 [339]	13-3/8 [339]										
20 [DN500]											10-3/4 [273]	13-1/2 [342]	19-1/2 [495]	13-3/8 [339]	13-3/8 [339]	10-3/4 [273]	13-1/2 [342]	19-1/2 [495]	13-3/8 [339]	13-3/8 [339]

\* 175 PSI [1206 KPA] CLOSE-OFF UP TO 12 INCHES [DN 300], 150 PSI [1034 KPA] OTHERWISE.

\*\*NOTE: VALVE SIZES 2 TO 3 INCHES ARE AVAILABLE ONLY WITH FULL CUT DISKS.

M27014

Fig. 10. 2-Way VFF1, VFF2 dimensions with high pressure, spring return pneumatic actuators

VFF1, VFF2, VFF3, VFF6 RESILIENT SEAT BUTTERFLY VALVES WITH FLANGED CONNECTIONS

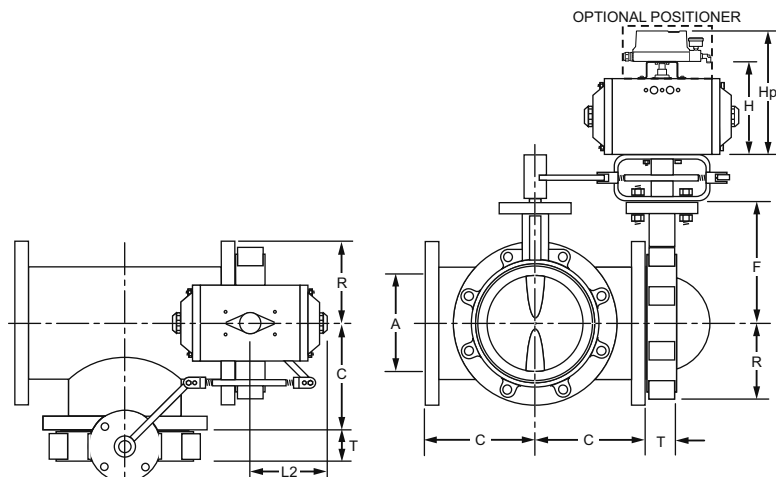

PIPE SIZE IN. [mm]	FULL CUT DISK, HIGH CLOSE-OFF* (VFF3/6_W1YCS/DS/ES/PS/XS)					UNDER CUT DISK, 50 PSI CLOSE-OFF** (VFF3/6_V1YCS/DS/ES/PS/XS)				
	W	H	HP	L1	L2	W	H	HP	L1	L2
2 [DN50]	2-3/4 [70]	4-1/4 [109]	10-1/4 [262]	3 [76]	3 [76]					
2-1/2 [DN65]	3-5/8 [91]	5-2/8 [132]	11-2/8 [284]	4 [100]	4 [100]					
3 [DN80]	4 [100]	5-1/2 [141]	11-1/2 [293]	4-1/2 [113]	4-1/2 [113]					
4 [DN100]	4-3/4 [120]	6-7/8 [176]	12-7/8 [328]	6 [154]	6 [154]	4 [100]	5-1/2 [141]	11-1/2 [293]	4-1/2 [113]	4-1/2 [113]
5 [DN125]	5-3/8 [137]	7-3/4 [196]	13-3/4 [349]	6-1/8 [157]	6-1/8 [157]	4-3/4 [120]	6-7/8 [176]	12-7/8 [328]	6 [154]	6 [154]
6 [DN150]	6-3/4 [172]	9-3/8 [238]	15-3/8 [391]	7-3/4 [196]	7-3/4 [196]					
8 [DN200]						6-3/4 [172]	9-3/8 [238]	15-3/8 [391]	7-3/4 [196]	7-3/4 [196]
10 [DN250]	8-7/8 [224]	11-5/8 [295]	17-5/8 [447]	9-1/2 [240]	9-1/2 [240]					
12 [DN300]						8-7/8 [224]	11-5/8 [295]	17-5/8 [447]	9-1/2 [240]	9-1/2 [240]
14 [DN350]	10-3/4 [273]	13-1/2 [342]	19-1/2 [495]	13-3/8 [339]	13-3/8 [339]					
16 [DN400]										
18 [DN450]						10-3/4 [273]	13-1/2 [342]	19-1/2 [495]	13-3/8 [339]	13-3/8 [339]
20 [DN500]										

\* 175 PSI [1206 KPA] CLOSE-OFF UP TO 12 INCHES [DN 300]. 150 PSI [1034 KPA] AT 14 INCHES AND NO PRODUCT AVAILABLE GREATER THAN 14 INCHES.

\*\*NOTE: VALVE SIZES 2 TO 3 INCHES ARE AVAILABLE ONLY WITH FULL CUT DISKS. M27023

Fig. 11. 3-way VFF3, VFF6 dimensions with 80 psi (high pressure) pneumatic spring return actuators

VFF3 DEFAULT CONFIGURATION

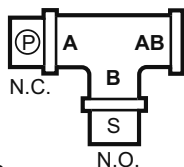

VFF6 DEFAULT CONFIGURATION  
(NOT AVAILABLE WITH LOW PRESSURE PNEUMATIC ACTUATORS)

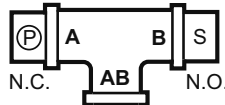

NOTES:

P = ACTUATOR AND PRIMARY VALVE

S = SLAVE VALVE

VIEWED FROM ABOVE

VFF3 VALVE ACTION IS MIXING FOR FLUID FLOW FROM LEFT TO RIGHT.

VFF3 VALVE ACTION IS DIVERTING FOR FLUID FLOW FROM RIGHT TO LEFT.

VFF6 MAY BE PIPED FOR MIXING CONTROL WITH WATER EXITING PORT AB, OR FOR DIVERTING CONTROL WITH WATER ENTERING PORT AB.

M27015

Fig. 12. VFF3, VFF6 3-Way valve assembly porting configurations

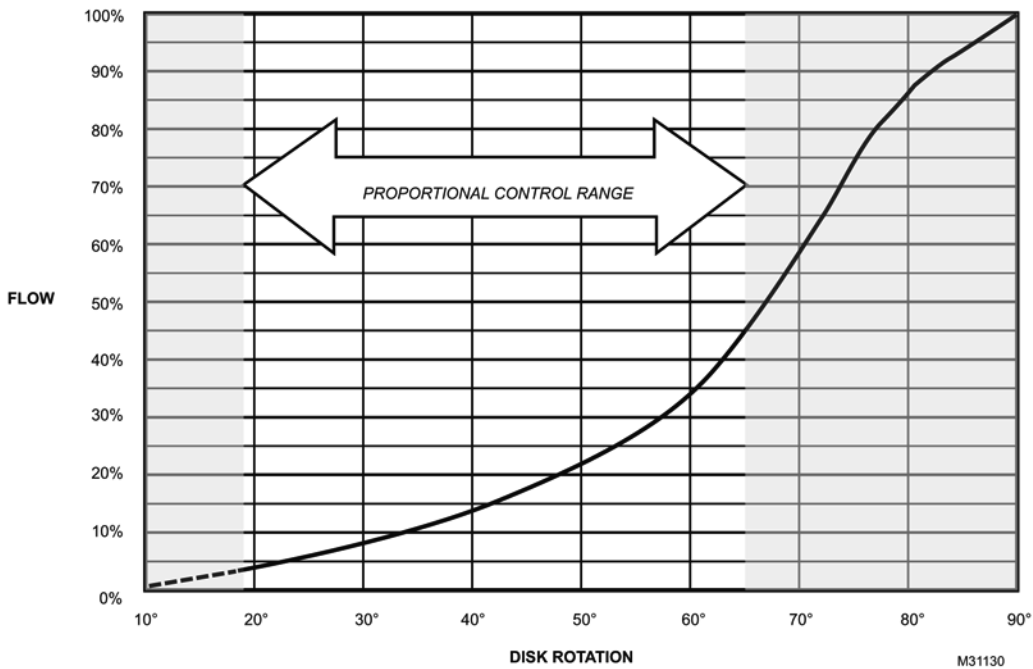
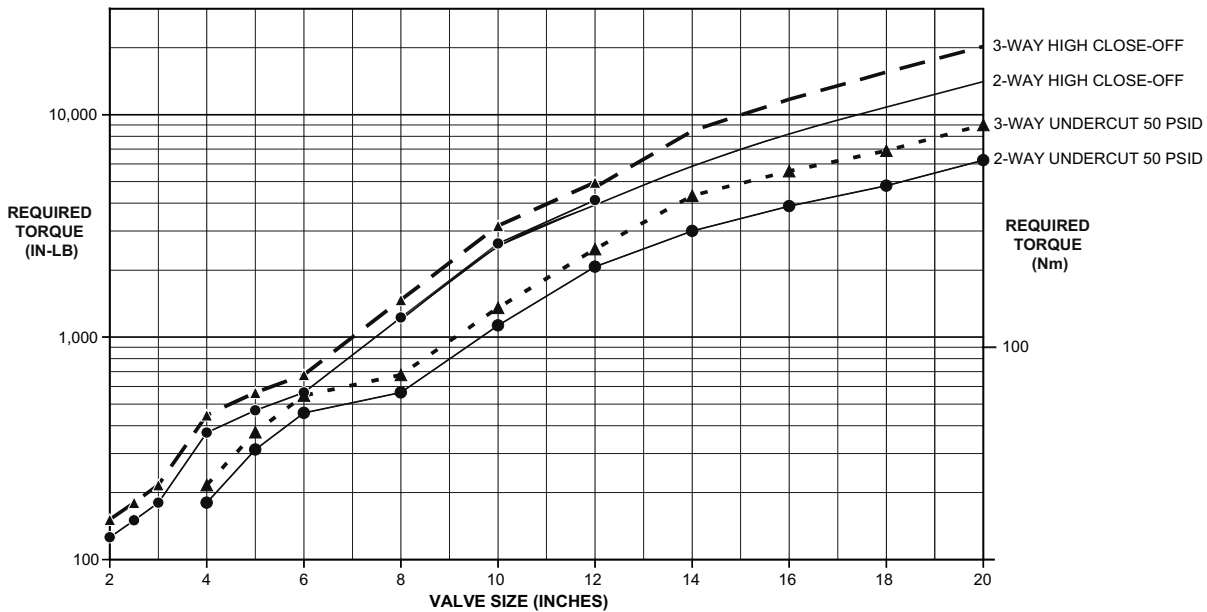

Fig. 13. Typical VFF Flow Characteristics



NOTES: FOR REFERENCE ONLY. ACTUATORS SUPPLIED MEET OPERATING TORQUE REQUIREMENTS FOR WATER-GLYCOL AND WATER CONTROL. CHART DOES NOT APPLY TO MANUAL VALVES, WHICH USE OVERCUT DISKS.

TORQUE OF PNEUMATIC ACTUATORS VARIES WITH SUPPLY AIR PRESSURE.

ACTUATOR TORQUE REDUCTION WILL REDUCE CLOSE-OFF RATINGS OF VALVES WITH FULL CUT DISK.

M27017

Fig. 14. VFF butterfly valves seating/unseating torque requirements

## INSTALLATION

### When Installing this Product:

1. Read these instructions carefully. Failure to follow them could damage the product or cause a hazardous condition.
2. Check ratings given in instructions and on the product to ensure the product is suitable for your application.
3. Observe and follow all national, state/provincial, local plumbing, fire and electrical codes.
4. Installers must be licensed pipe fitters, electricians and/or service technicians. This publication requires all installers to be trained and experienced in their trades.
5. After installation is complete, check out product operation as provided in these instructions.
6. Full close-off ratings for automated valves apply only when valve is mounted between two flanges. Valve close-off is de-rated when installed on one flange in end-of-line service due to lack of compression on seat seal. Close-off rating of 2 to 12 inch full cut valves mounted to a single flange is 75 psi. Close-off rating of 14 to 20 inch full cut valves mounted to a single flange is 50 psi.

## Preparation

### Safety

Honeywell assumes no responsibility for damages or injuries resulting from non-compliance with installation instructions or standard good practice when mounting, operating, or maintaining the valves, even if not explicitly mentioned in the installation instructions.



## CAUTION

### Equipment Damage Hazard:

- Foreign particles like dirt and metal chips can damage valve seals. For trouble-free operation of the product, good installation practice must include initial system flushing, and chemical water treatment. The presence of excessive rust ( $\text{Fe}_2\text{O}_3$ ) in the system may void Warranty.
- Clean the lines upstream of particles larger than 1/16 inch (1 mm) diameter (welding slag, pipe scale, sand and other suspended particulate). Use of a 50 micron (or finer) system side-stream filter is suggested. Remove all filters before flushing. Use of 20 mesh strainers in the system is recommended.
- Follow boiler or chiller manufacturer's recommendations for water treatment such as rust inhibitors, acidity, etc.
- Rapid increases in pH levels can create excessive quantities of magnetite ( $\text{Fe}_3\text{O}_4$ ) in systems with iron piping and other components.
- Do not use boiler additives, solder flux and wetted materials which are petroleum-based or contain mineral oil, hydrocarbons, or ethylene glycol acetate. These may cause the seat to swell, impairing operation. If treating system withazole-based compounds, system must be thoroughly flushed before filling, or resilient seat may be damaged. Compounds which can be used, with minimum 50% water dilution, are diethylene glycol, ethylene glycol, and propylene glycol (antifreeze solutions).
- If installing these valves in an addition to, or retrofitting and existing building, do not assume that the fluid in the existing piping meets these criteria for water quality or treatment.

## Valve Installation

### Location

Select a location where the valve and actuator will be accessible, once installed. Allow sufficient space for servicing the valve and actuator. Clearance for valve installation is dependent on actuator size and the valve pipe size. Refer to Figures 1 to 6 for valve body and actuator dimensions.

1. Clean the lines upstream of the valve to remove particles larger than 1/16 inch (1 mm) diameter (welding slag, pipe scale, metal filings, and other contaminants) to prevent damaging or obstructing disk operation.
2. Air should be eliminated from the system so that valves remain full of fluid during operation.
3. To prevent interference with disk operation, a butterfly valve should be installed at least 6 pipe diameters away from other pipe line elements. Where this is impractical, care must be taken to ensure free operation of the disk to prevent damage to moving parts and actuators.
4. Proceed with installation once the system specifics (expansion/contraction of the system and its medium as well as operating pressures) are within tolerances.
5. Valve may be installed with actuator(s) mounted, if preferred.

### Mounting 2-way Valves

1. Before installing the valve, rotate the valve stem manually to make sure that the valve stem operates freely. Impaired stem operation can indicate that the stem was bent by rough handling. This condition **may** require replacing the valve.
2. Protect the stem from damage due to bending or scratching.
3. For horizontal piping, install the valve so the actuator is in any position between vertical and horizontal, but preferably above the valve. Do not install the valve with the stem below horizontal or upside down unless splash-proof or waterproof actuators are used. For vertical piping, the actuator can be mounted in any orientation. See Fig. 15.

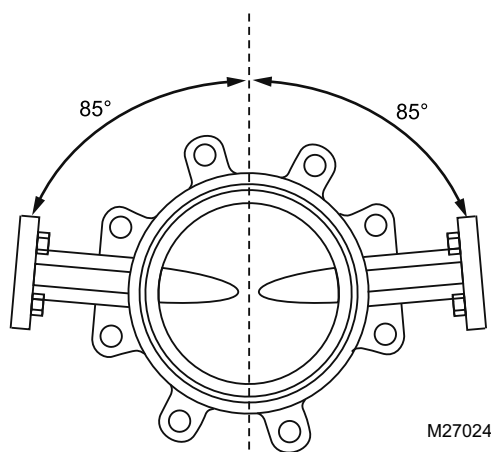

Fig. 15. Butterfly valve orientations for Honeywell direct coupled actuators (DCA's)

4. Hoist valve by its body or neck only, using a nylon sling. Do not lift by actuator, manual operator, or flange holes. (See Fig. 16 for proper hoisting method.)

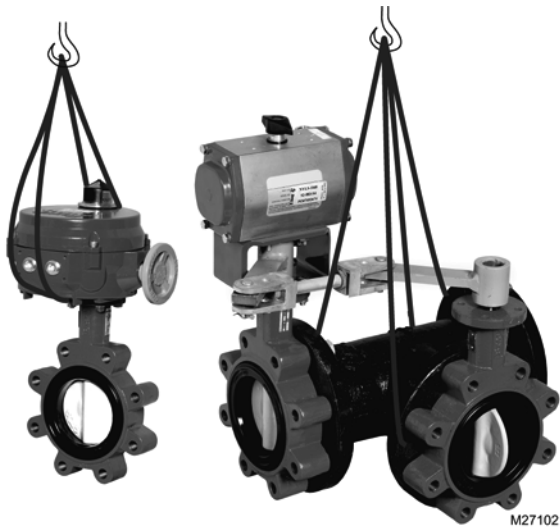

Fig. 16. Butterfly valve hoisting techniques

5. Mount the valve between aligned pipes. Mounting the valve on pipes that are not aligned causes leakage at the valve-to-pipe connection and add excess strain to flange bolt lugs. See Fig. 17.

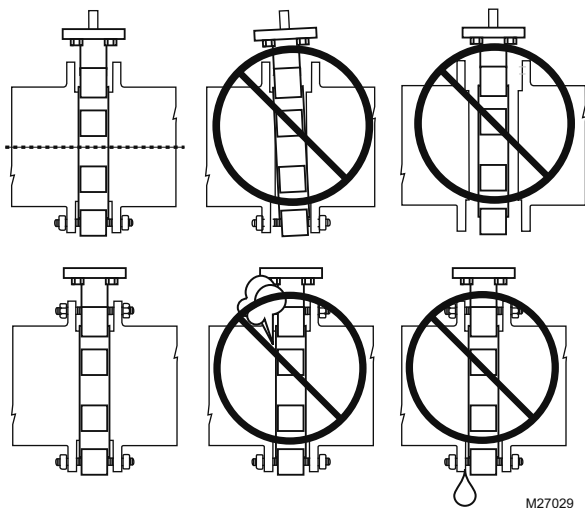

Fig. 17. Proper flange alignment

6. If installing into an existing system, release system pressure and drain the valve pipe section so the medium (water or glycol solution) does not leak out of the valve body during installation.
7. Iron valves are mechanically compatible with standard ANSI Class 150-flat faced or raised-face steel flanges, or with ANSI Class 125 cast iron flanges. Either neck-weld or slip-on flanges may be used; however, *Type C stub-end flanges are not recommended*. See Fig. 18.

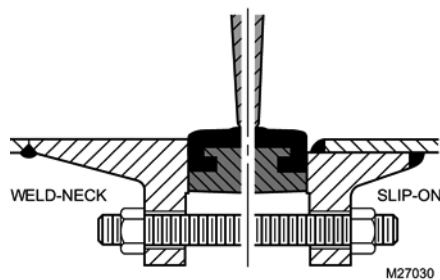

Fig. 18. Flange welding techniques

8. When using welded flanges, loosely assemble valve and flanges using flange bolts with disk open about 10°. Tack weld flanges to pipes. Remove valve from flanges to prevent heat damage and complete flange welding.
9. When flanges have cooled from welding, position the disk in the partially open position, about 10°, keeping the disk at least 3/8 in. (7 mm) inside the body faces. See Fig. 19.

**NOTE:** The flats of the Double-D valve stem are parallel to the faces of the disk. Valves are shipped with the disks open slightly to avoid compression set of the resilient seat.

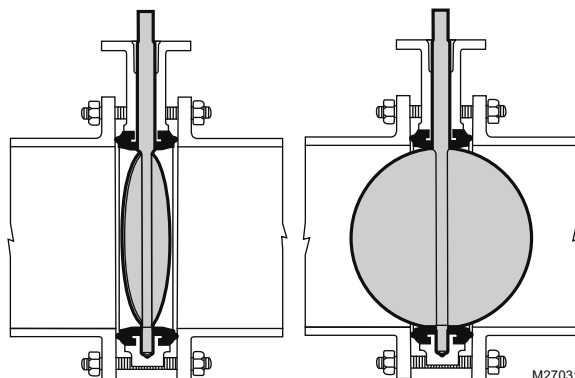

Fig. 19. Valve installation disk positions

10. Spread the pipe flanges. Taking care not to damage the resilient seat gasket, place the body between the flanges, and install all flange bolts. **Do NOT use flange gaskets;** the resilient seat serves this purpose.
11. The disk will project into the attached piping. *Before tightening flange bolts,* carefully open the disk to the full position to ensure proper alignment and clearance of the disk O.D. with the adjacent pipe I.D. Leave disk in full open position. Snug bolts “hand tight” and then use wrench to tighten bolts an additional quarter to half-turn using a staggered pattern, as with wheel rims of a car. Take care not to over-tighten flange bolts -- compression of rubber increases disk friction.

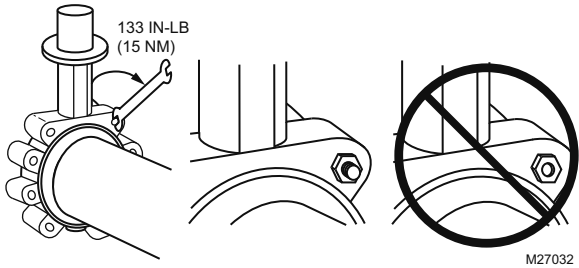

Fig. 20. Flange bolt installation guidelines

12. Once bolts are tightened, carefully rotate disk to closed position to ensure disk O.D. clearance.
13. Proceed to check out operation of actuator.

### Mounting 3-way Valve Assemblies

1. Prepare piping as described in steps 1 to 8, in section “Mounting 2-way Valves”, above.
2. Mount three-way valves as shown in Fig. 23, according to whether they are to be used for mixing or diverting control. **Note that valve ports are NOT identified on the assembly.** VFF3 valve assembly is factory configured to figure 7a with A port normally closed, but linkage may be adjusted to any position. Note that the B port in Fig. 23 is always the side port of a VFF3 assembly. VFF6 valve assembly is factory configured to figure 7b, but linkage may be adjusted to any position. Note also that the AB (common) port is always the side port of a VFF6 assembly. *Adjust the linkage as needed prior to installation.*
3. Position the disk of the first flange to be attached in the partially open position, keeping the disk within the body faces. See Fig. 23.
4. Attach the first flange and install flange bolts. See Table 1 for bolt specifications. **Do NOT use flange gaskets;** the resilient seat serves this purpose.
5. Before tightening flange bolts, carefully open the disc to the full open position to ensure proper alignment and clearance of the disk O.D. with the adjacent pipe I.D. Leave disk in full open position and tighten flange bolts per required specification.
6. Once bolts are tightened, carefully rotate disc to closed position to ensure disk O.D. clearance.
7. Repeat steps 3 to 6 above to attach the second flange.
8. Proceed to check out operation of actuator.

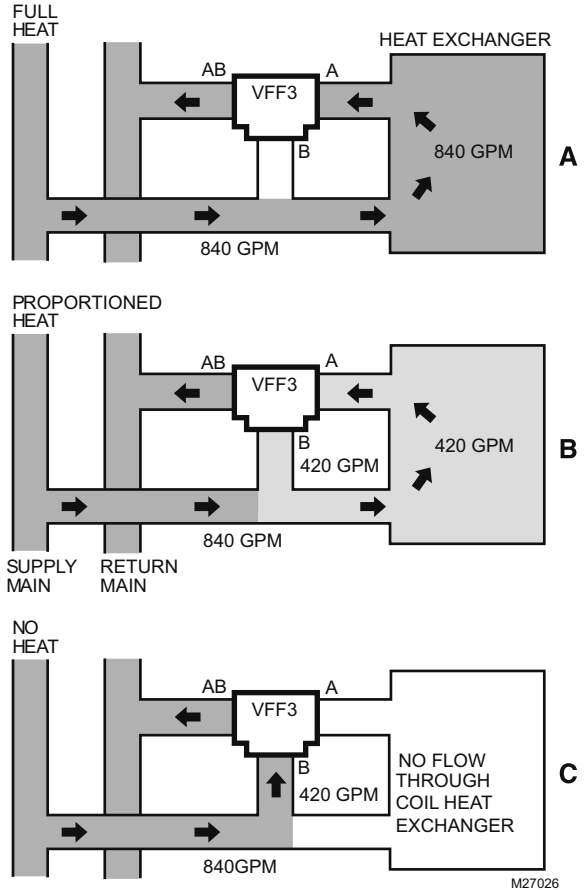

Fig. 22. 3-Way mixing valve operation with coil bypass

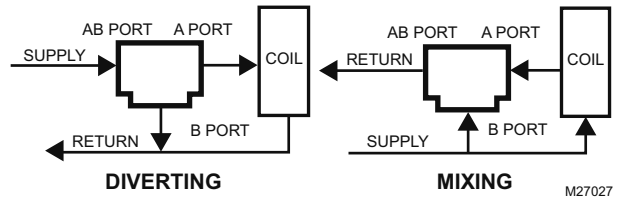

Fig. 23. 3-Way VFF3 butterfly valve flow orientation

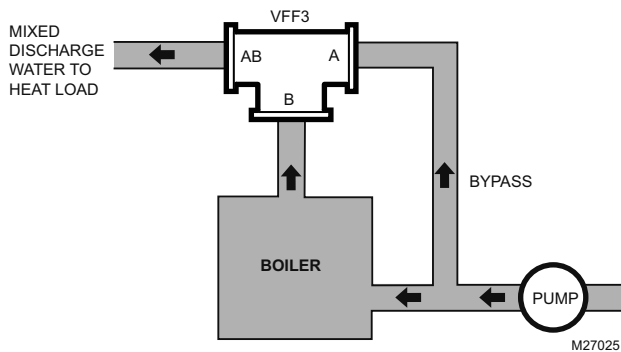

Fig. 21. Boiler bypass for reset control

### Mounting Actuator

For information on actuator (removal and mounting), refer to the operating and maintenance data sheet included with the specific actuator coupled to the valve. It is important to have selected the correct actuator available for the application.

**NOTE:** Honeywell Environmental and Combustion Control does not recommend its products for use in high precision, process control applications. ECC products are designed for typical Heating, Ventilating and Air-Conditioning applications.

## Electrical Installation

1. If necessary, remove actuator wiring cover.
2. Wire actuator using specific wiring instructions that come with each actuator.
3. Replace cover.

### Notes:

- With the exception of MS4120A, Honeywell DCAs are 24Vac Class II electrical products.

- All industrial-grade (NEMA 4/4X) actuators are Class I devices, wired using 120Vac, 50/60Hz power.
- Pneumatic actuators are available with several electro-pneumatic interface options, including line and low voltage solenoids for two-position control, and 4-20 mA server for modulating control.
- For convenience, typical wiring diagrams are reproduced in Figures 24-28.

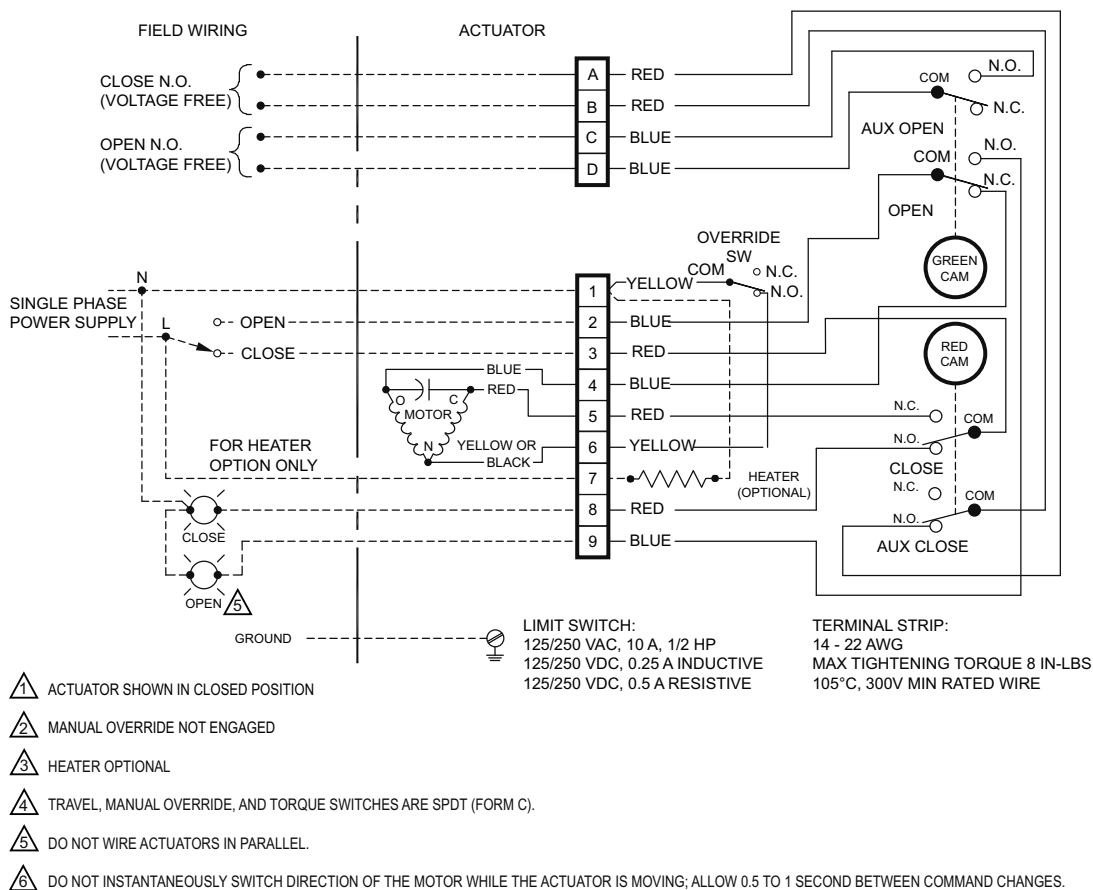

**Fig. 24. NEMA 4X floating/2-position industrial-grade actuator for valves up to 18" (VFF...XA)**

VFF1, VFF2, VFF3, VFF6 RESILIENT SEAT BUTTERFLY VALVES WITH FLANGED CONNECTIONS

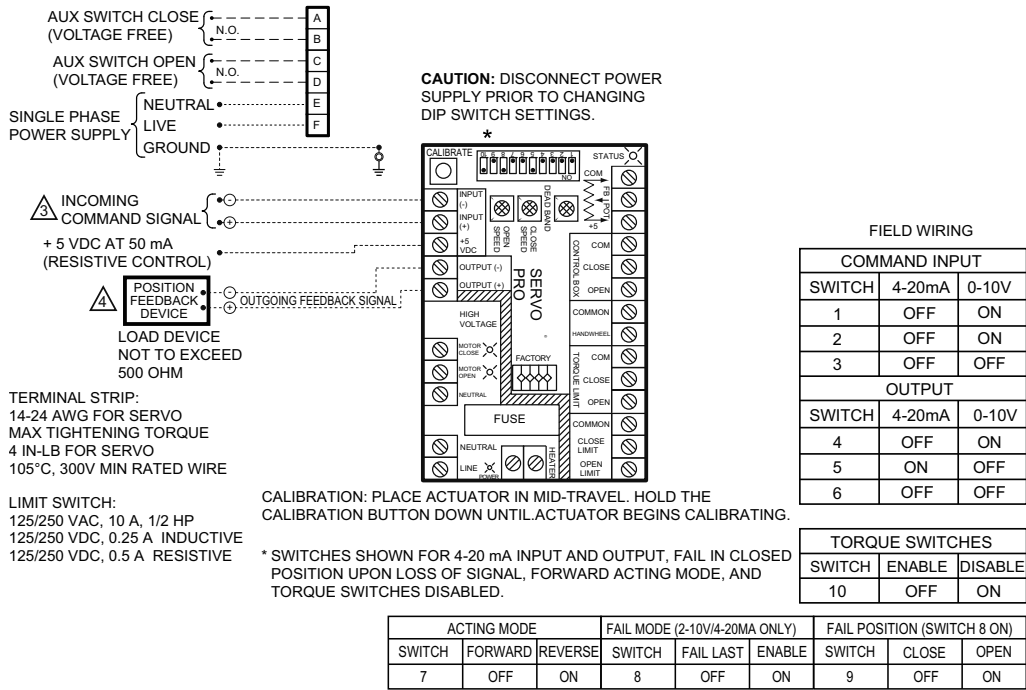

- ⚠ ACTUATOR SHOWN IN CLOSED POSITION.
- ⚠ MANUAL OVERRIDE NOT ENGAGED.
- ⚠ COMMAND SIGNAL AND FEEDBACK SIGNAL MUST BE ISOLATED FROM EACH OTHER AND ANY OTHER CIRCUIT.
- ⚠ FEEDBACK LOOP IS POWERED BY THE SERVO, DO NOT SUPPLY EXTERNAL POWER.
- ⚠ SEE MANUAL FOR DETAILS.
- ⚠ HEATER OPTIONAL.
- ⚠ TRAVEL LIMIT AND MANUAL OVERRIDE SWITCHES ARE SPDT (FORM C).
- ⚠ SEE NAME TAG FOR POWER RATING.

**Fig. 25. NEMA 4X modulating industrial-grade actuator for valves up to 18" (VFF...XB)**

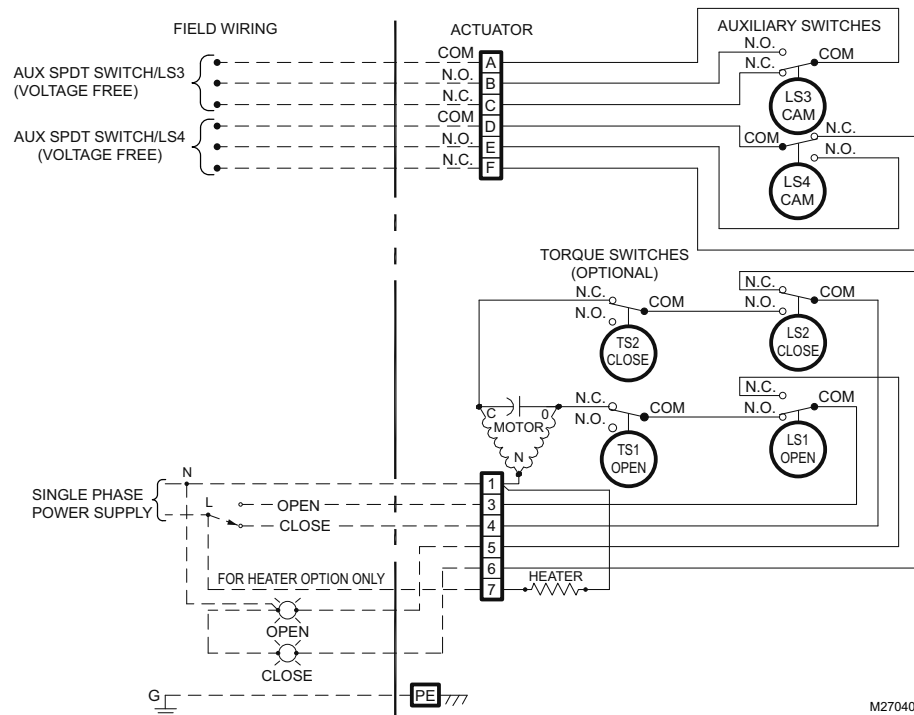

**Fig. 26. NEMA 4 floating/2-position industrial-grade actuator for valves 14" to 20" (VFF...4A)**

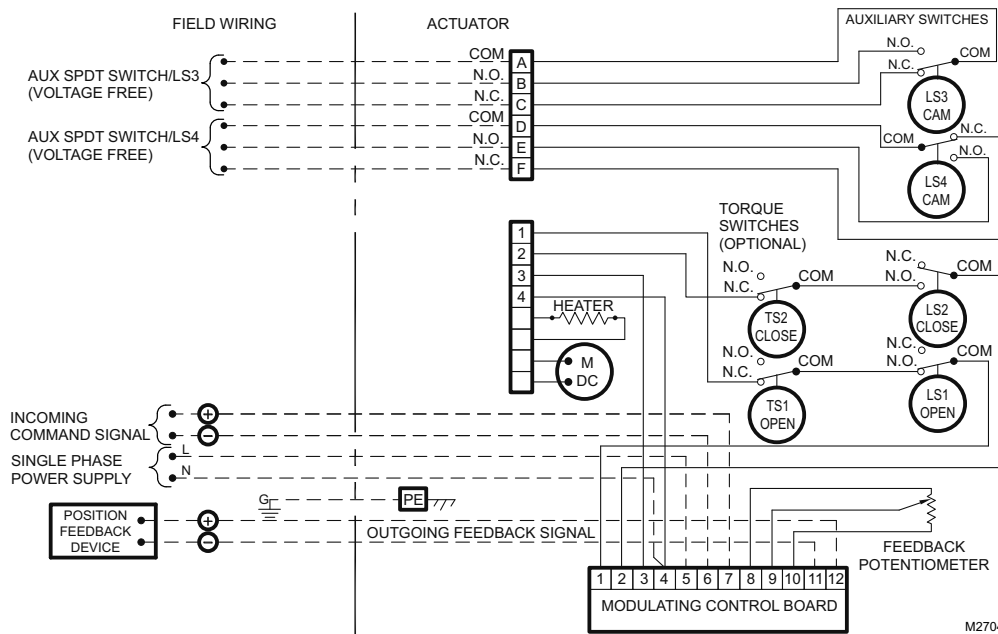

**Fig. 27. NEMA 4 modulating industrial-grade actuator for valves 14" to 20" (VFF...4B)**

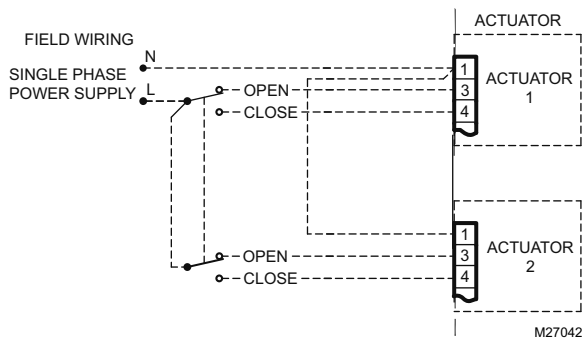

**Fig. 28. Unison operation of floating/2-position industrial-grade line voltage actuators using interface relay**

## OPERATION AND CHECKOUT

**NOTE:** Proper valve close-off depends on the disk closing fully to compress the resilient rubber seats. Valves are shipped in the slightly open position, used for initial placement, and so that the seat does not ‘set’ and leave a groove from the disk. It is not recommended to leave the disk in the seat for extended periods of time when the valve is not installed. When installed, it is recommended to open the valve periodically. Disk position when actuators are removed from installed valve bodies can be determined by noting the flats of the Double-D valve stem are parallel to the faces of the disk.

### Checkout

For instructions for operating the valve actuator, see the specific actuator’s Product Data Sheet. Wiring terminal connections for industrial-grade electric actuators are included

in this publication for reference operate the control system and check valve operation to determine that the valve stem positions the disk smoothly through its full stroke without binding.

Ensure that the actuator selected provides the force to position the valve disk. For electric spring-return actuators, the actuator provides normally closed or normally open operation on electric power or pressure failure, depending on the valve/ actuator combination selected.

### General

Spring return actuators return the valve to its normal position (open or closed, depending on the actuator and valve selected) in the event of a power failure. Non-spring return actuators hold the last commanded position.

Pneumatic spring return actuators are factory configured as normally open (VFF1) or normally closed (VFF2). VFF3 and VFF6 3-way valve assemblies are factory configured with the A port normally closed, but the valve linkage may be field-adjusted to one of several other orientations.

Pneumatic actuator torque will vary proportionally to supply air pressure. Depending on torque in excess of valve operating requirements, close-off pressure may vary from published ratings. With air pressure below 80 psi, high pressure bi-directional actuators will lose both seating and unseating torque. Normally open spring return actuators will lose close off torque. Normally closed spring return actuators will lose opening torque. Contact Honeywell for advice on specific, non-standard applications.

Valves with Honeywell spring return direct coupled actuators (DCAs) are shipped with the A port normally closed. This may be converted to normally open by removing the actuator(s), moving the shaft hubs to the other side of the actuator, and re-installing the actuator with the hub in its original orientation. (See Fig. 29.) More than one DCA may be used on the valve to achieve required operating torque.

Once both the mechanical and electrical installations are complete:

1. Cycle the actuator to verify that the direction of rotation suits the control sequence.
2. If the rotation direction is incorrect:
  - a. For 2-position control actuators: Remount actuator on the bracket.
  - b. For floating control actuators: Reverse two control signal wires (CW/CCW).
  - c. For analog control actuators either:
    - (1) Reposition reverse/direct acting switch, or
    - (2) Remount actuator on the bracket.
3. If the control scheme requires fail-safe operation, ensure that, upon removal of power, the fail position coincides with the control sequence.
4. If the fail safe position is incorrect, remove and reinstall the actuator in the opposite orientation as follows:
  - a. Loosen the shaft coupling bolt using a 10 mm wrench.
  - b. Loosen all other mounting bolts connecting the actuator to the mounting bracket, and set aside.
  - c. Remove the actuator from the valve shaft.
  - d. Move the actuator coupling to the opposite side of the actuator, as displayed in Fig. 29.

- (1) Remove the retainer clip from the shaft coupling and set it aside for later use.
- (2) Remove shaft coupling from one side of the actuator.
- (3) Replace the shaft coupling on the opposite side of the actuator, aligning it based on the stroke labeling.
- (4) Replace the retainer clip on the shaft coupling using the groove of the coupling.
- e. reconnect the actuator to the valve mounting bracket by replacing the screws previously removed (step b).
- f. Tighten the shaft coupling bolt using a 10 mm wrench.

For detailed actuator information, see Honeywell literature:

- 63-2588: MN6134, MN7234 Product Data
- 63-2607: MS7510, MS7520, MS8110, MS8120 Product Data

## TYPICAL SPECIFICATIONS Actuated Butterfly Valve

Valve housing shall consist of polyester-coated cast iron, rated at no less than 175 [or 250] low [or line] voltage psi at 250 F. Valve housing shall have ANSI Class 125/150 flanges. Valve disk shall consist of Nylon 11 coated ductile iron disk. Aluminum, bronze, and stainless steel are also available. Valve shall have a blow-out proof stem with two EPDM O-rings. Valve shall have resilient tongue-and-groove EPDM combination valve seat and flange seal with minimum, bubble-tight close-off pressure of 50 [or 150, or 175, or 250] psi.

## Valve Actuator

Electric control valve actuator shall accept analog modulating, floating (tri-state), or low [or line] voltage two-position signal as indicated in the control sequence. Pneumatic control valve actuators shall accept low pressure signal for proportional control, or 20 [or 80] psi air pressure signal for two-position control in a spring [or non-spring] return configuration. Actuators shall be provided by Honeywell. Actuator shall provide minimum torque required for full valve shutoff position. Wiring terminals shall be provided for installation to control signal and power wiring.

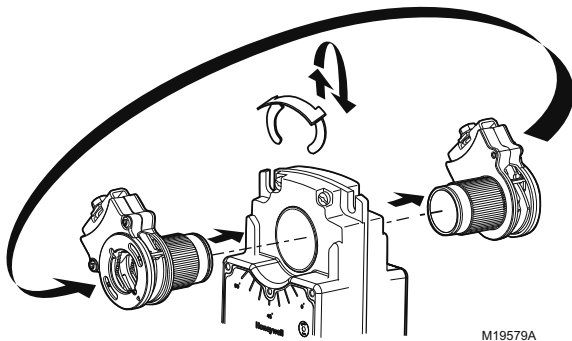

**Fig. 29. DCA spring return actuator coupling to opposite side of mounting shaft**

## Automation and Control Solutions

Honeywell International Inc.  
1985 Douglas Drive North  
Golden Valley, MN 55422  
customer.honeywell.com

# Honeywell