

# Solid Core and Split Core Fixed Current “Status” Switches

CSS-O, CSS-C; CSP-O, CSP-C

## PRODUCT DATA



## FEATURES

- Solid and split core, fixed current “go/no go” switches
- Very low operating trip points
- LED status indication
- Integral DIN rail mounting flange
- Easy installation, non-polarity sensitive
- Accepts up to a 350 MCM (17.3 mm) cable
- Operates up to 200 or 250 continuous amps
- Limited five year warranty
- RoHS and WEEE compliant

## DESCRIPTION

The CSS solid core series and CSP split core current switches have either Normally-Open (N.O.) or Normally-Closed (N.C.) output configurations. These sensors have a solid-state output with a fixed trip point (setpoint). These current switches are ideal for providing status information on any type of equipment where AC current will be monitored. The CSS series solid core current switches are an excellent choice for new installations. The CSP series split core current switches are ideal for retrofit or existing installations, since it is not necessary to power down the unit and disconnect any wires during the installation process. The CSS and CSP current switches are accurate, reliable, easy to install and require less servicing than differential pressure switches, flow switches and paddle wheels.

These current switches should be used in applications in which a “Go/No Go” current switch is required. A current switch can be used to monitor fan and pump status, motors,

compressors and any other electrical equipment for proper operation. A change in the operating current may indicate mechanical failure or that the unit has been turned off. Any time one of these events occur the current can significantly increase or decrease, thus tripping the sensor and notifying building management of an alarm condition.

The CSS and CSP series current switches can be used to monitor devices with a maximum continuous operating current of up to 200 or 250 Amps depending on the model. These current switches do not need to be externally powered, since the power for the switch is induced from the conductor being monitored. Another great feature of the CSS and CSP series current switches is that they include a red “Status” LED that will indicate whether the current is above the fixed trip point. All of these units come with a unique 1.4 in. (35 mm) DIN Rail mounting flange and an unconditional 5 year limited warranty.

## Contents

Features .....	1
Description .....	1
Specifications .....	2
Ordering Information .....	2
Safety .....	3
Installation .....	3
Troubleshooting .....	6



63-2650—1

## SPECIFICATIONS

**Sensor Power:** Induced from monitored conductor

**Dimensions:** See Figures 1 and 2

**Amperage Rating:** 0 to 200 Amps and 0 to 250 Amps  
(See Table 1)

**DIN Rail Size:** 1.4 in. (35 mm)

**Operating Frequency:** 40 Hz to 1 kHz

**Unit Weight:**

CSS: 0.21 lb. (0.1 kg)

CSP: 0.23 lb. (0.1 kg)

**Isolation Voltage:** 2200 Vac

**Enclosure Rating/Color:** UL94-5VB/Burgundy

**Max Sensing Current Voltage:** 600 Vac

**Operating Temperature Range:** 5° to 104°F (-15° to 40°C)

**Output Switch Ratings:**

CSS-O; CSP-O (N.O.): 0.3 Amps @ 200 Vac/Vdc

CSS-C; CSP-C (N.C.): 0.15 Amps @ 300 Vac/Vdc

**Operating RH Range:** 0 to 95% RH, non-condensing

**Fixed Trip Point (Setpoint):** See Table 1

**Agency Approvals:**

CE, UL.

Environmental Compliance:

RoHS-Directive 2002/95/EC,

WEEE-Directive 2002/96/EC.

**Status LED Indication:** Red LED - Above Trip Point

NOTE: DO NOT use the LED's to indicate whether the sensors have power applied to them.

**Aperture (Hole) Size:** 3/4 in. (19 mm), Accepts up to 350 MCM (17.3 mm) Cables

**Table 1. Operating Specifications**

Product Number	Fixed Trip Point	Core Type	Normal Position	Output Switch Rating	Max. Current Cont.	Max. Current for 6 secs.	Max. Current for 1 sec.
CSS-O-F5-001	0.50 Amps	Solid	N.O.	0.30 Amps @ 200 Vac/Vdc	250 Amps	500 Amps	1,000 Amps
CSS-O-F1-001	0.20 Amps	Solid	N.O.	0.30 Amps @ 200 Vac/Vdc	250 Amps	500 Amps	1,000 Amps
CSS-C-F5-001	1.00 Amps	Solid	N.C.	0.15 Amps @ 300 Vac/Vdc	250 Amps	500 Amps	1,000 Amps
CSS-C-F1-001	0.50 Amps	Solid	N.C.	0.15 Amps @ 300 Vac/Vdc	250 Amps	500 Amps	1,000 Amps
CSP-O-F15-001	2.50 Amps	Split	N.O.	0.30 Amps @ 200 Vac/Vdc	200 Amps	400 Amps	800 Amps
CSP-O-F10-001	1.50 Amps	Split	N.O.	0.30 Amps @ 200 Vac/Vdc	200 Amps	400 Amps	800 Amps
CSP-C-F15-001	2.50 Amps	Split	N.C.	0.15 Amps @ 300 Vac/Vdc	250 Amps	400 Amps	800 Amps

## ORDERING INFORMATION

When purchasing replacement and modernization products from your TRADELINE® wholesaler or distributor, refer to the TRADELINE® Catalog or price sheets for complete ordering number.

If you have additional questions, need further information, or would like to comment on our products or services, please write or phone:

1. Your local Honeywell Automation and Control Products Sales Office (check white pages of your phone directory).
2. Honeywell Customer Care  
1885 Douglas Drive North  
Minneapolis, Minnesota 55422-4386

In Canada—Honeywell Limited/Honeywell Limitée, 35 Dynamic Drive, Toronto, Ontario M1V 4Z9.

International Sales and Service Offices in all principal cities of the world. Manufacturing in Australia, Canada, Finland, France, Germany, Japan, Mexico, Netherlands, Spain, Taiwan, United Kingdom, U.S.A.

SOLID CORE AND SPLIT CORE FIXED CURRENT "STATUS" SWITCHES

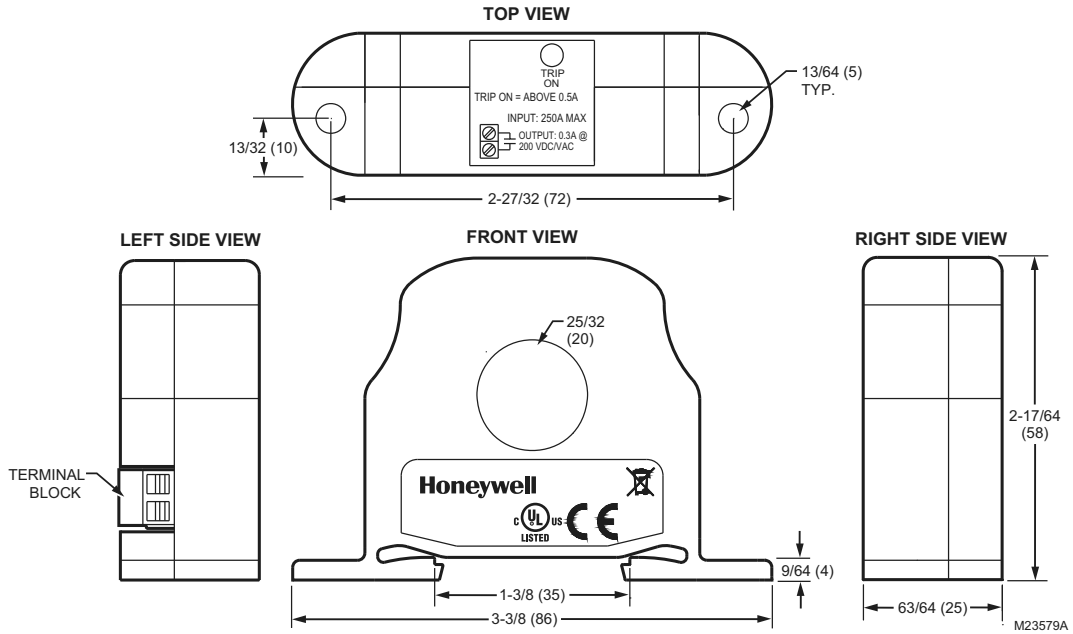

Fig. 1. CSS current switch dimensions in inches (mm)

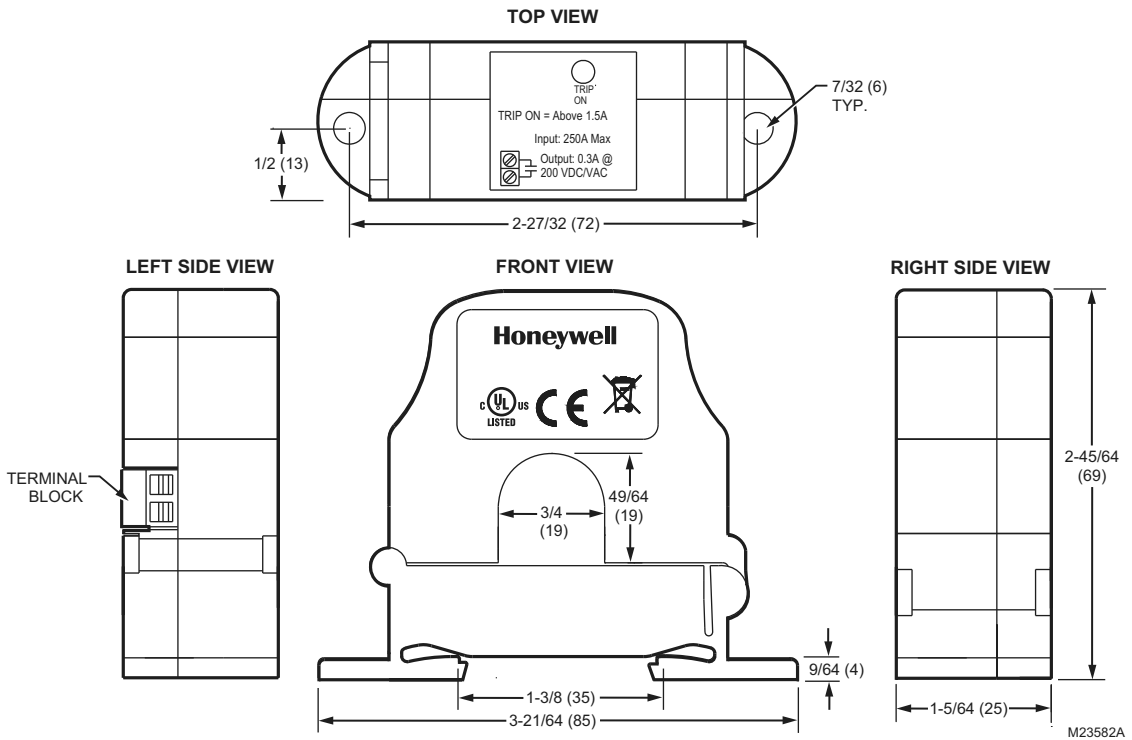

Fig. 2. CSP current switch dimensions in inches (mm)

## SAFETY

### ⚠ WARNING

For CSS-O,C ensure that all power sources are disconnected and locked out before installation as severe injury or death may result from electrical shock due to contact with high voltage wires.

### ⚠ CAUTION

This product is not intended to be used for life safety applications.

### ⚠ CAUTION

This product is not intended for use in any hazardous or classified locations.

## INSTALLATION

Make sure that all installations are in compliance with all national and local electrical codes. Only qualified individuals that are familiar with codes, standards, and proper safety procedures for high-voltage installations should attempt installation. The current switches will not require external power, since power for the current switch is induced from the conductor being monitored.

### ⚠ WARNING

Never rely on the red LED to determine whether power is present at the current switch. The red LED will indicate whether the current is above (LED On) or below (LED Off) the fixed trip point.

#### IMPORTANT

*The current switch should be used on insulated conductors only!*

The current switch may be mounted in any position using the (2) #8 x 3/4 in. (19 mm) Tek screws and the mounting holes in the base snapped directly on to the 1.4 in. (35 mm) DIN rail (See Figures 3 and 4). Leave a minimum distance of 1 inch (25 mm) between the current switch and any other magnetic devices, such as contactors and transformers.

For applications in which the normal operating current is below the 0.2 Amps or 0.5 Amps trip point (See Table 1), the conductor being monitored may be looped through the sensor 4/10 multiple times to increase the current flowing through the sensor (See Fig. 5).

#### Examples:

A small fan operating at 0.2 Amps can be wrapped through the sensor 4 times to give you a total operating current of 0.8 Amps flowing through the CSS-O-F5-001. Another option is to use the CSS-O-F1-001, which has a lower operating current

A small fan operating at 0.2 Amps can be wrapped through the sensor 14 times to give you a total operating current of 2.8 Amps flowing through the CSP-O-F15-001. Another option is to use the CSP-O-F10-001.

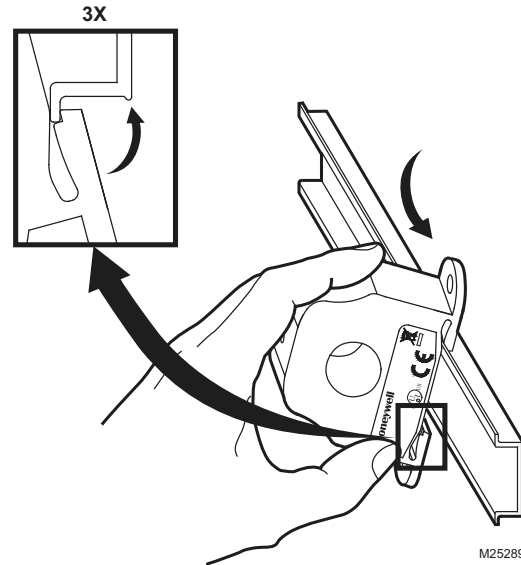

Fig. 3. Sensor placed on DIN rail

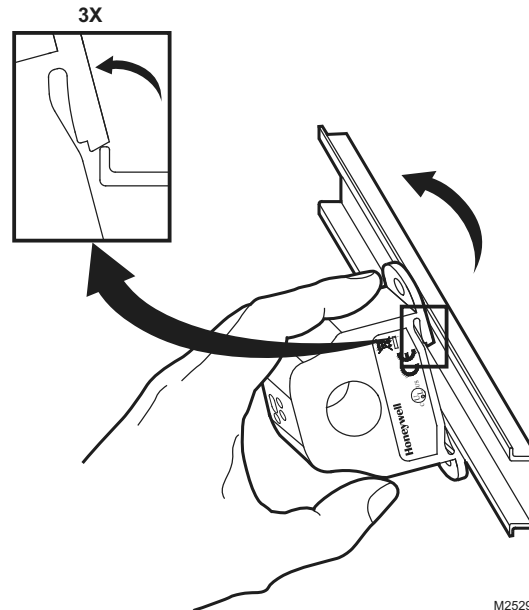

Fig. 4. Sensor removed from DIN rail

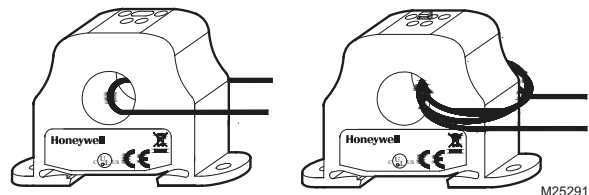
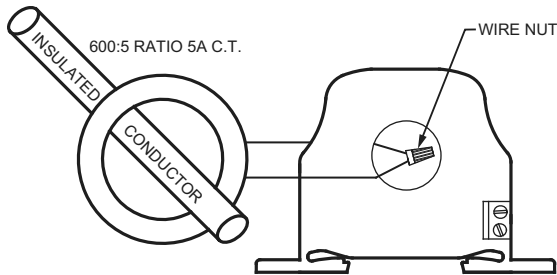

Fig. 5. Wires through sensors

## **! WARNING**

**Remember that the secondary of the 5 Amps Current Transformer must be shorted together before the power may be turned on to the monitored device.**

For applications in which the normal operating current is greater than 250 Amps or for conductor diameters larger than 3/4 in. (19 mm) in diameter, an external 5 Amp Current Transformer (C.T.) must be used as shown in Fig. 6.



EXAMPLE: FOR CURRENTS UP TO 600 AMPS, USE A 600:5 RATIO C.T. AS SHOWN. M25295A

**Fig. 6. Current transformer**

## **Latch Operation (for Split Core)**

Pressing down on the two (2) side tabs and swinging the cover open opens the split core current switch as shown in Fig. 7. Lifting up the latch with a flat-tip screwdriver as shown in Fig. 8 can also open the unit. Press down firmly on the cover to close the current switch. An audible "click" will be heard as the tab slides over the tongue on the base.

## **! CAUTION**

**Mating surfaces of the magnetic core are exposed when the sensor is open. Silicone grease, present on the cores to prevent rust, can capture grit and dirt if care is not exercised. Operation can be impaired if anything prevents good contact between pole pieces. Visually check the mating parts of the core before closing the current sensor.**

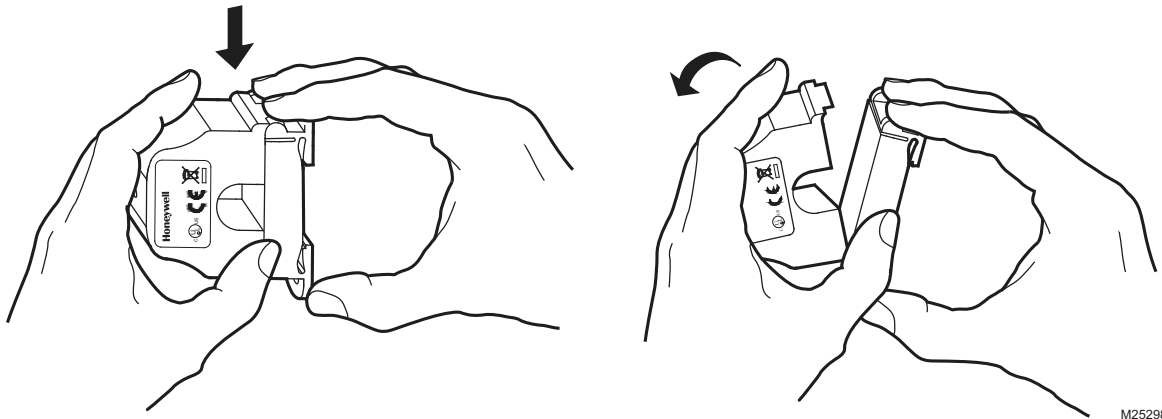

**Fig. 7. Opening sensor by hand**

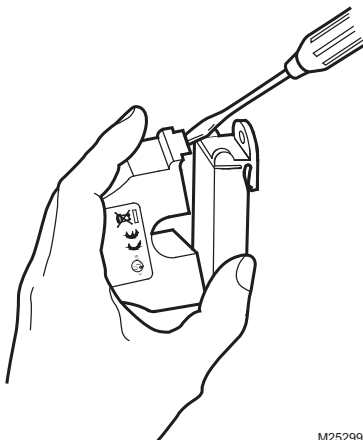

**Fig. 8. Opening sensor with a screwdriver**

## **Wiring**

Honeywell recommends the use of a 2 conductor 16 to 22 AWG (1.3 to 0.3 mm<sup>2</sup>) shielded cable or twisted pair, copper wire only, for all current switch output applications. A maximum wire length of less than 98.4 feet (30 meters) should be used between the current switches and the Building Management System or controller.

When using a shielded cable, be sure to connect only (1) end of the shield to ground at the controller. Connecting both ends of the shield to the ground may cause a ground loop.

When removing the shield from the sensor end, make sure to properly trim the shield so as to prevent any chance of shorting. The current switch output terminals represent a solid-state switch for controlling AC and DC loads and is not polarity sensitive. The recommended torque to be used on the terminal block connections is 5.93 in.-lbs. (0.67 Nm). The aperture (hole) size of the current switch is 3/4 in. (19 mm) and will accept a

## SOLID CORE AND SPLIT CORE FIXED CURRENT “STATUS” SWITCHES

maximum cable diameter of 350 MCM (17.3 mm). See Fig. 9 for use as a digital input to a building management system and Fig. 10 for use as a pilot relay type application.

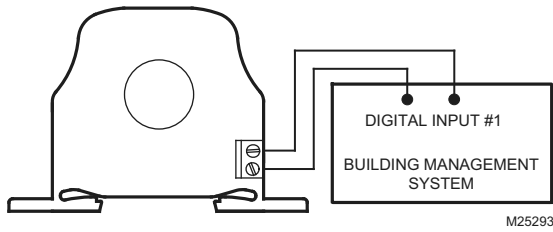

Fig. 9. Digital circuit

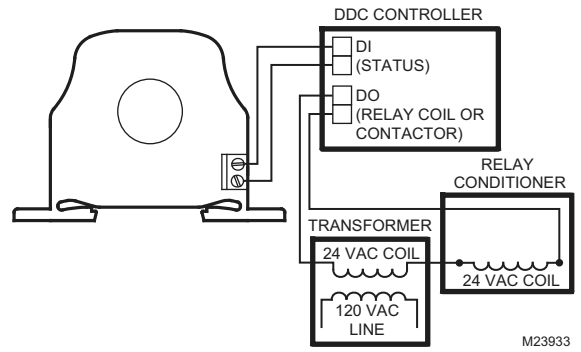

Fig. 10. Analog circuit

## TROUBLESHOOTING

Problem	Solution
LED is on but the current switch didn't activate	<ul style="list-style-type: none"> <li>Disconnect the wires from the current switch output. Measure the resistance across the contacts with an Ohmmeter. See Table 2 for the actual resistance readings for an open or closed switch reading.</li> </ul>
LED didn't turn on and the current switch didn't activate	<ul style="list-style-type: none"> <li>Verify that the current flowing in the conductor being monitored is above the fixed trip point as listed in the operating specifications. If the sensor is monitoring less than the fixed trip point, see Fig. 5.</li> </ul>
LED not on but the Current Switch is Activated	<ul style="list-style-type: none"> <li>LED not indicating correctly, may have been damaged.</li> </ul>

Table 2. Resistance readings for a good unit

Product Number	Resistance if switch is open	Resistance if switch is closed
CSS-O-F5-001	Greater than 1 Meg ohms	Approximately 2 ohms
CSS-O-F1-001	Greater than 1 Meg ohms	Approximately 2 ohms
CSS-C-F5-001	Greater than 1 Meg ohms	Approximately 12 ohms
CSS-C-F1-001	Greater than 1 Meg ohms	Approximately 12 ohms
CSP-O-F15-001	Greater than 1 Meg ohms	Approximately 2 ohms
CSP-O-F10-001	Greater than 1 Meg ohms	Approximately 2 ohms
CSP-C-F15-001	Greater than 1 Meg ohms	Approximately 12 ohms



**Automation and Control Solutions**

Honeywell International Inc.  
1985 Douglas Drive North  
Golden Valley, MN 55422  
customer.honeywell.com

Honeywell Limited-Honeywell Limitée  
35 Dynamic Drive  
Toronto, Ontario M1V 4Z9

® U.S. Registered Trademark  
© 2007 Honeywell International Inc.  
63-2650—1 C.H. Rev. 06-07



Printed in U.S.A. on recycled  
paper containing at least 10%  
post-consumer paper fibers.

**Honeywell**