

5 Nm, 10 Nm Series

NON-SPRING RETURN DIRECT-COUPLED DAMPER ACTUATORS FOR FLOATING AND TWO-POSITION CONTROL

PRODUCT DATA

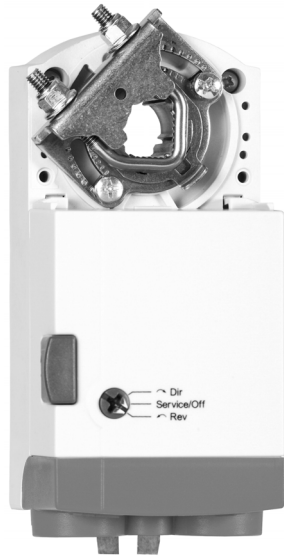

GENERAL

This non-spring return direct-coupled damper actuator provides floating and two-position control for:

- air dampers,
- VAV units,
- air handlers,
- ventilation flaps,
- louvers, and
- reliable control for air damper applications with up to 10 sq ft (0.9 sq m) / 44 lb-in. (5 Nm) and 20 sq ft (1.9 sq m) / 88 lb-in. (10 Nm) (seal-less damper blades; air friction-dependent).

FEATURES

- Declutch for manual adjustment.
- Adjustable mechanical end limits.
- Removable access cover for direct wiring.
- Mountable in any orientation.
- Rotation direction and service/OFF switch.
- Available with cable on select models.

SPECIFICATIONS

Supply voltage:

MN6105/MN6110: 24 Vac/Vdc -15%/+20%, 50/60 Hz.

Nominal voltage:

MN6105/MN6110: 24 Vac/Vdc, 50/60 Hz.

All values stated herein after apply to operation under nominal voltage conditions.

Power consumption:

MN6105/MN6110: 5 VA / 2 W.

Ambient limits:

Ambient operating limits: -5...+140° F (20...+60° C).
Ambient storage limits: -22...+176° F (-30...+80° C).
Relative humidity: 5...95%, non-condensing.

Safety:

Protection standard: IP54.
Protection class: II as per EN 60730-1.
Overvoltage category: II.

Lifetime:

Full strokes: 60000.
Repositions: 1.5 million.

Contents

General	1
Features	1
Specifications	1
Ordering Information	2
Installation	3
Wiring	4



Mounting:

Round damper shaft: 3/8...5/8 in. (9.5...15.9 mm).
 Square damper shaft: 1/4...1/2 in. (6.4...12.7 mm);
 45° steps.
 Shaft length: min. 1-5/8 in. (41.3 mm).

End switches (when included):

Rating: Class II.
 Triggering points: 5° / 85°.

Torque rating: 44 lb-in. (5 Nm) / 88 lb-in. (10 Nm).

Runtime for 90°:

MN6105: 0 sec (dc / 60 Hz ac).
 MN6110: 90 sec (dc / 50 Hz ac).

Rotation stroke: 95° ± 3°.

Dimensions: See Dimensions (see Fig. 10).

Weight (without cables): 1 lbs (0.45 kg).

Noise rating: 35 dB(A) max. at 1 m (39 in.).

Cable Specification:

300 V, 75° C, Plenum Rated, 3 ft length from end of access cover, 18 AWG

BASIC FEATURES

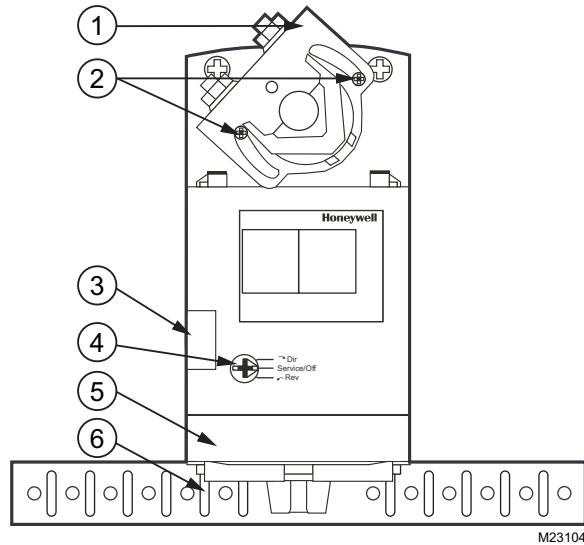

Fig. 1. Setting Units and Control Elements.

PRODUCT IDENTIFICATION SYSTEM

M	Electrical Motor
N	Fail Safe Function (Non-Spring Return)
61	24 Vac Floating, Two-Position Control; Reversible Mount
75	24 Vac Modulating
05	44 lb-in. (5 Nm)
A	Standard U.S. Model
W	Standard U.S. Model with Cable*
1	No Feedback
2	Voltage Feedback Signal
0	No End Switches
2	Two End Switches
XX	System Controlled Numbers

M N 61 05 A 1 0 XX

*Cables available on MN7505W2001 or MN6105W1011 only.

Legend for Fig. 1:

1. Universal shaft adapter.
2. Mechanical end limits (manually adjustable).
3. Declutch button.
4. Function selection switch.
5. Removable access cover.
6. Anti-rotation bracket.

Contents of Package

The delivery package includes the actuator, parts 1 through 6 (see Fig. 1), plus two cable grommets and a spare cable grommet.

RUN MODES

The function selection switch (see Fig. 2) can be used to place the actuator into any one of two different modes:

- Service/Off; or

ORDERING INFORMATION

When purchasing replacement and modernization products from your TRADELINE® wholesaler or distributor, refer to the TRADELINE® Catalog or price sheets for complete ordering number.

If you have additional questions, need further information, or would like to comment on our products or services, please write or phone:

1. Your local Honeywell Automation and Control Products Sales Office (check white pages of your phone directory).
2. Honeywell Customer Care
 1885 Douglas Drive North
 Minneapolis, Minnesota 55422-4386

In Canada—Honeywell Limited/Honeywell Limitée, 35 Dynamic Drive, Toronto, Ontario M1V 4Z9.

International Sales and Service Offices in all principal cities of the world. Manufacturing in Australia, Canada, Finland, France, Germany, Japan, Mexico, Netherlands, Spain, Taiwan, United Kingdom, U.S.A.

- The floating/2-position run mode (“Dir” for CCW-closing dampers or “Rev” for CW-closing dampers).

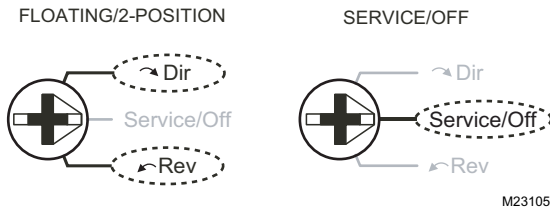

Fig. 2. Function Selection Switch.

Power-Off Behavior

If power is removed, the shaft adapter remains in position.

Service/Off

If the function selection switch is set to the “Service/Off” position, then all rotary movement is cancelled, and all control signals are ignored, thus allowing the actuator to be manually operated safely.

Floating/2-Position Run Mode

If the function selection switch has been set to one of the two floating/2-position control settings—and if the actuator is wired correspondingly (see Figures 7 through 9)—then as soon as operating power is applied, the shaft adapter will run according to the control signals applied.

Table 1 describes the behavior (“stops,” rotates “CCW,” or rotates “CW”) of the MN6105/MN6110 in dependence upon the control signals (switch “open” or “24 Vac/dc”) applied to terminals 3 and 4, the function selection switch setting, and the manner in which the actuator is wired (either for floating mode: see Fig. 7; or for 2-position mode: See Fig. 8).

Table 1. Behavior of MN6105/MN6110.

Wiring	Control Signal At:		Switch Setting:		
	Term 3	Term 4	Dir	Service/Off	Rev
Float	Open	Open	Stops	Stops	Stops
	Open	24 Vac/Vdc	CCW	Stops	CW
	24 Vac/Vdc	Open	CW	Stops	CCW
2-Pos.	24 Vac/Vdc	Open	CW	Stops	CCW
	24 Vac/Vdc	24 Vac/Vdc	CCW	Stops	CW

MANUAL ADJUSTMENT

IMPORTANT

To prevent equipment damage, before manual adjustment, you must remove power or set the function selection switch to the “Service/Off” position.

After removing power or setting the function selection switch to the “Service/Off” position, the gear train can be disengaged using the declutch button, permitting the shaft adapter to be manually rotated to any position.

Limitation of Rotation Stroke

Two adjustable mechanical end limits are provided to limit the angle of rotation as desired (See Fig. 3). The mechanical end limits must be securely fastened in place.

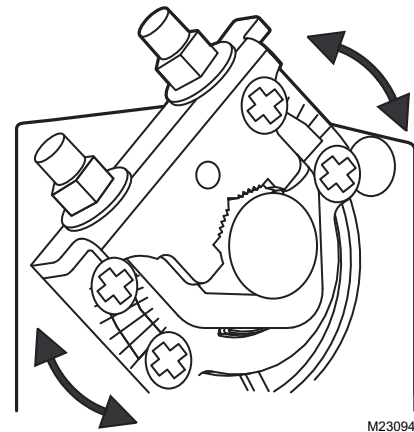

Fig. 3. Mechanical End Limits

To ensure tight closing of the dampers, the shaft adapter has a total rotation stroke of 95°.

INTERNAL END SWITCHES

The internal end switches “A” and “B” are changeover switches which are activated when the shaft adapter moves past a position of 5° and 85°, respectively (See Table 3).

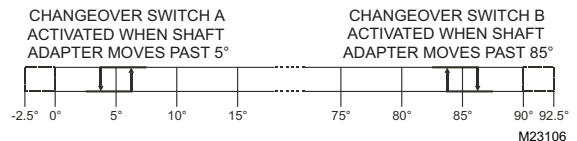

Fig. 4. Internal End Switch Triggering Points.

INSTALLATION



CAUTION

To avoid personal injury (electrical shock) and to prevent equipment damage, before installation, you must remove power.

These actuators are designed for single-point mounting.

Mounting Instructions

All information and steps are included in the Installation Instructions (See form no. 62-0224) supplied with each actuator.

Mounting Position

The actuators can be mounted in any position (IP54 is dependent upon orientation; see Fig. 8). Choose a mounting position permitting easy access to cables and controls.

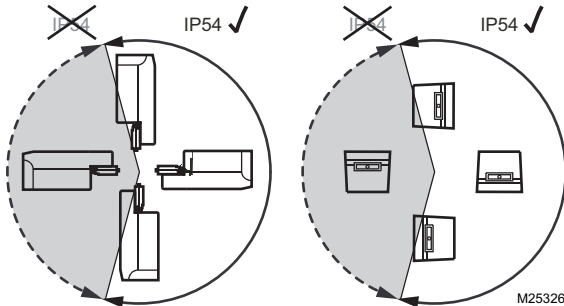

Fig. 5. Mounting for IP54.

NOTE: Further, in order to guarantee IP54, only original Honeywell grommets may be used.

Anti-Rotation Bracket and Screws

If the actuator is to be mounted directly on a damper shaft, use the anti-rotation bracket and screws included in the delivery package. The minimum distance between the center of the damper shaft and the middle of the anti-rotation bracket is 3.35 in. (85 mm); a maximum of 4.25 in. (108 mm) is allowed (See Fig. 10).

Depending upon the specifics of your mounting site, the actuator may shift in position slightly while tightening the screws at the top of the shaft adapter. The anti-rotation bracket features a T-piece with a 3/16 in. (5 mm) long shank to accommodate for this movement. It is important to ensure that this play is not impeded.

Universal Shaft Adapter

The universal shaft adapter can be used for shafts of various diameters and shapes (round: 3/8...5/8 in. (9.5...15.9 mm) and square: 1/4...1/2 in. (6.4...12.7 mm)).

WIRING

CAUTION

To avoid personal injury (electrical shock) and to prevent equipment damage, before wiring, you must remove power.

Access Cover

IMPORTANT

Once the access cover has been removed, please take care to avoid damaging any of the parts now accessible.

The access cover can be unscrewed and removed in order to gain access to the terminal block(s) and perform wiring.

NOTE: If factory installed wires not included.

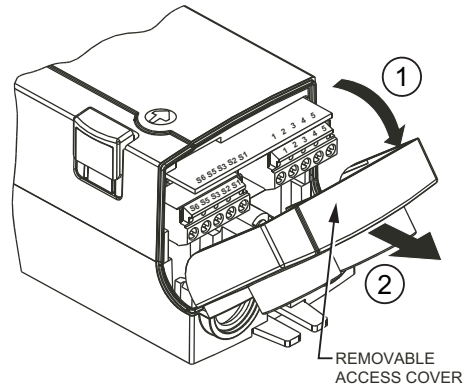

Fig. 6. Access Cover.

Typical Wiring Without Cables

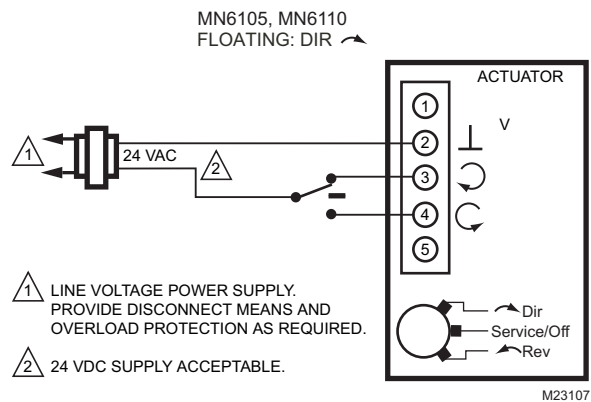

Fig. 7. MN6105/MN6110 (Floating Mode).

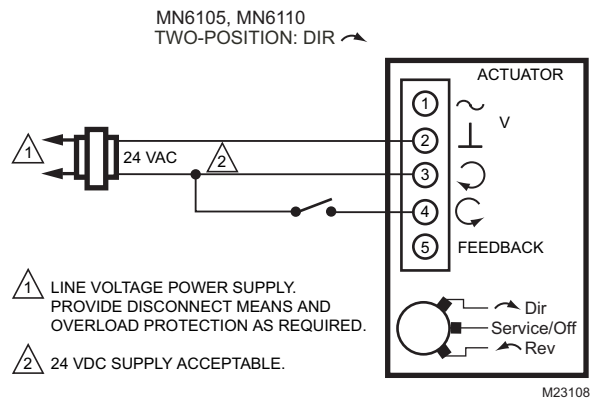

Fig. 8. MN6105/MN6110 (2-position mode)

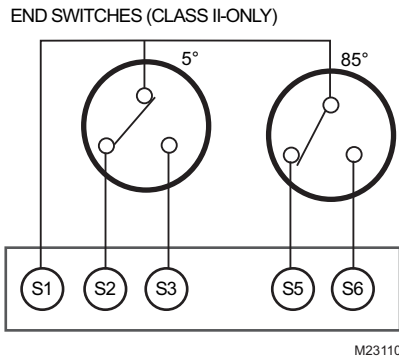

Fig. 9. End Switches.

NOTE: Both internal end switches must be connected to the same power source.

Tables 2 and 3 summarize the information presented in the preceding wiring diagrams.

Table 2. Signals at Terminals from MN6105/MN6110.

Terminal	Signal in Floating	Signal in 2-Pos. Mode
2	Common ~/-	Common ~/-
3	24 V ~/- (control signal)	24 V ~/- (control/power signal)
4	24 V ~/- (control signal)	24 V ~/- (control/power signal)
NOTE: All cables connected to these terminals must be equipped with spark suppression.		

Table 3. Internal End Switches.

Terminal	Type of Switch
S1	Common lead for switches A and B.
S2/S3	Change-over switch A (S1/S2 opens and S1/S3 closes when shaft adapter moves CC past 5°; reverts to original state when shaft adapter moves CCW past 5°).
S5/S6	Change-over switch B (S1/S6 closes when shaft adapter moves CW past 85°; reverts to original state when shaft adapter moves CCW past 85°).

Typical Wiring With Cables

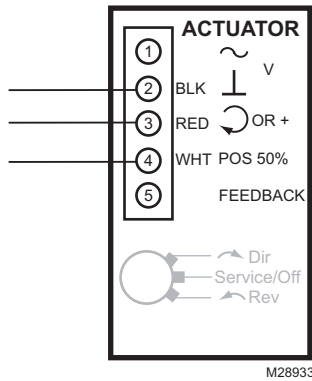

Fig. 10. MN6105W1011 Two Position/Floating.

DIMENSIONS

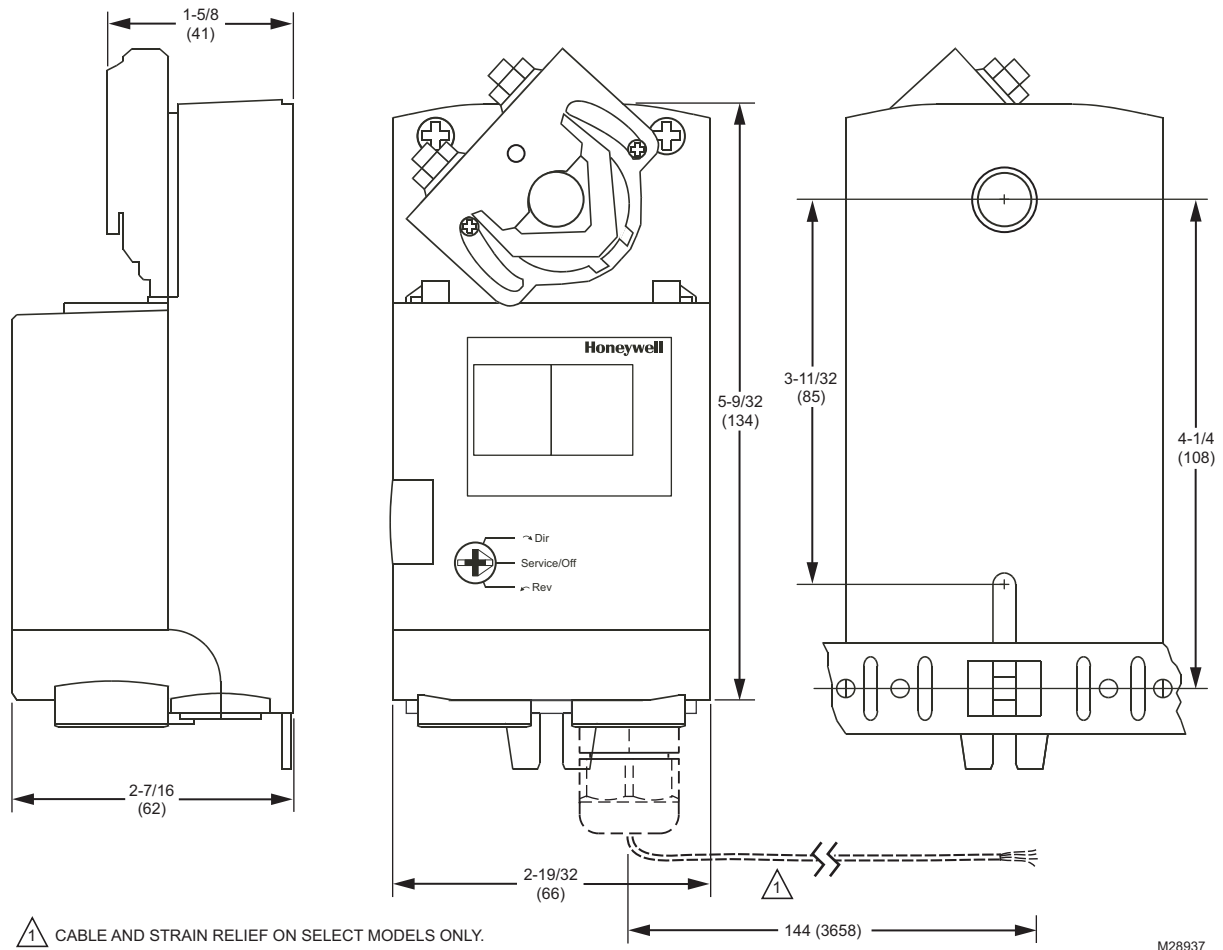

Fig. 11. Dimensions in inches (mm).

5 NM, 10 NM SERIES

Automation and Control Solutions

Honeywell International Inc.
1985 Douglas Drive North
Golden Valley, MN 55422

Honeywell Limited-Honeywell Limitée
35 Dynamic Drive
Toronto, Ontario M1V 4Z9
customer.honeywell.com

® U.S. Registered Trademark
© 2010 Honeywell International Inc.
EN0B-0544GE51 R0810
63-2632—03 M.S. Rev. 10-10
Printed in U.S.A.

Honeywell