

## N20010-SER

### NON-SPRING RETURN DAMPER ACTUATOR

### 20 Nm (177 lb-in) FOR ADJUSTABLE MODULATING CONTROL

#### PRODUCT DATA

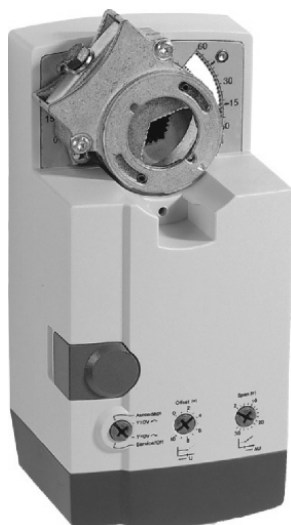

#### GENERAL

These direct-coupled damper actuators provide adjustable modulating control for:

- air dampers,
- VAV units,
- air handling units,
- ventilation flaps,
- louvers, and
- reliable control for air damper applications with up to 4.6 m<sup>2</sup> / 50 sq.ft. (seal-less damper blades; air friction-dependent).

#### FEATURES

- **New self-centering shaft adapter**
- **Access cover to facilitate connectivity**
- **Declutch for manual adjustment**
- **Mechanical end limits**
- **Field-installable auxiliary switches**
- **Pre-wired (non-U.S. models)**
- **Rotation direction selectable by switch**
- **Mountable in any orientation (no IP54 if upside down)**
- **Mechanical position indicator**
- **UL-approved (U.S. models, only)**

#### SPECIFICATIONS

<b>Supply voltage</b>	24 Vac $\pm$ 20%, 50/60 Hz; 24 Vdc -10...+20%
<b>Nominal voltage</b>	24 Vac, 50/60 Hz; 24 Vdc
<i>All values stated hereinafter apply to operation under nominal voltage conditions.</i>	
<b>Power consumption</b>	6 VA / 6 W
<b>Ambient limits</b>	
Ambient operating limits	-20...+60 °C (-5...+140 °F)
Ambient storage limits	-40...+80 °C (-40...+175 °F)
Relative humidity	5...95%, non-condensing
<b>Cables</b>	
Length	1 m (39")
Materials	silicone-free
<b>Safety</b>	
Protection standard	IP54 as per EN 60529
Protection class	II as per EN 60730-1
Overvoltage category	II
<b>Lifetime</b>	
Full strokes	60000
Repositions	1.5 million
<b>Mounting</b>	
Round damper shaft	10...27 mm (3/8...1-1/16")
Square damper shaft	10...18 mm (3/8...11/16"); 45° steps
Shaft length	min. 22 mm (7/8")
<b>Control signal</b>	
	0...10 Vdc / 0...30 Vdc 0...20 mA / 0...60 mA
Offset range	0...10 Vdc (0...20 mA); default 0 V (0 mA)
Working span range	2...32 Vdc (4...64 mA); default 10 V (20 mA)
Input impedance	100 k $\Omega$ [0...10 V] 500 $\Omega$ [0...20 mA]
<b>Feedback signal</b>	
Limits	$\pm$ 1 mA at 0...10 V
<b>Auxiliary switch (when included)</b>	
Rating	5 A (resistive) / 3 A (inductive)
Triggering points	5° / 85°
<b>Torque rating</b>	20 Nm (177 lb-in)
<b>Runtime</b>	95 sec (60 Hz) / 110 sec (50 Hz)
<b>Rotation stroke</b>	95° $\pm$ 3°
<b>Dimensions</b>	see "Dimensions" on page 8
<b>Weight (without cables)</b>	1.35 kg (3 lbs.)
<b>Noise rating</b>	40 dB(A) max. at 1 m
<b>Software</b>	Class A as per EN 60730-1



## MODELS

order number	supply voltage	auxiliary switches	control signal	feedback	torque
N20010-SER	24 Vac / 24 Vdc	--	0...30 Vdc / 0...60 mA	0...10 Vdc	20 Nm (177 lb-in)
N20010-SER-SW2	24 Vac / 24 Vdc	2	0...30 Vdc / 0...60 mA	0...10 Vdc	20 Nm (177 lb-in)

## Product Identification System

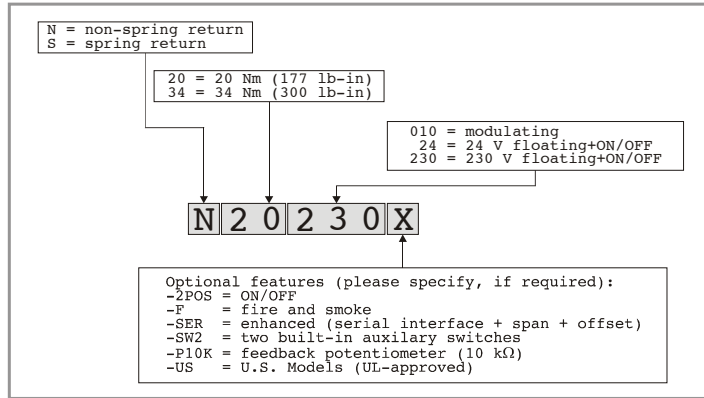

Fig. 1. Product Identification System

## OPERATION / FUNCTIONS

### Overview

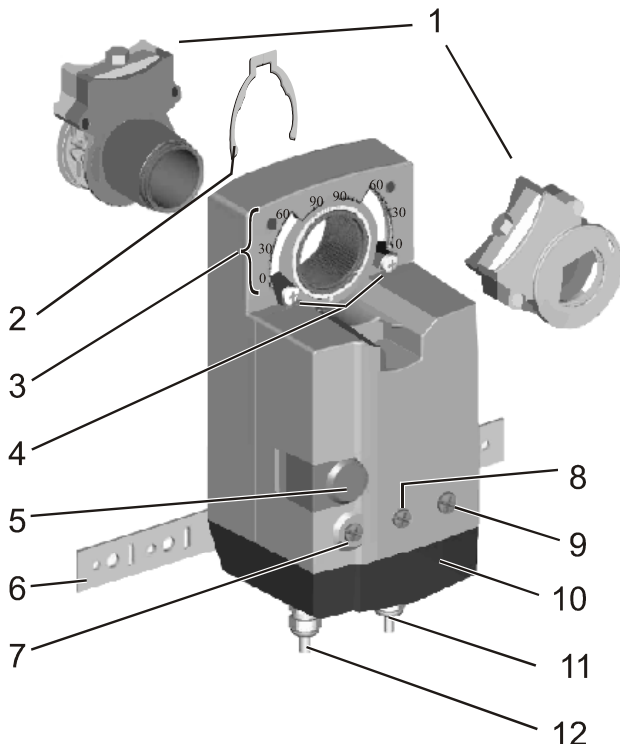

Fig. 2. Setting units and control elements

### Legend for Fig. 2:

1. Self-centering shaft adapter (front or reverse mounting)
2. Retainer clip
3. Rotational angle scales (0...90° / 90...0°)
4. Mechanical end limits
5. Declutch button
6. Anti-rotation bracket
7. Rotation direction switch
8. Control signal offset adjustment
9. Control signal span adjustment
10. Access cover
11. Internal auxiliary switch wire
12. Power and control switch wire

### Contents of Package

The delivery package includes the actuator, itself, parts 1 through 12 (see Fig. 2), the anti-rotation bracket screws, and the SM mounting plate and screws.

### Modulating Control

The actuator is capable of being operated by several controllers providing Vdc or mA output.

### Rotary Movement

The control signal and corresponding rotation direction (clockwise or counterclockwise) can be selected using the rotation direction switch (see part 7 in Fig. 2), thus eliminating the need to re-wire. To ensure tight closing of the dampers, the actuator has a total rotation stroke of 95°.

As soon as operating power is applied, the actuator may start to run. When power is removed, the actuator remains in position. For actuator-controller wiring instructions, see "Wiring Diagrams" on page 6.

### Rotation Direction Switch

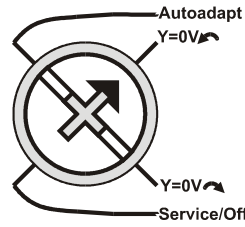

Fig. 3. Rotation direction switch

- **"Autoadapt"** (for set-up): When the rotation direction switch is set to this position, the actuator will drive to the mechanical end limits (clockwise and counterclockwise), acknowledge them, and then remap the control signal settings accordingly. Upon completion of this process, the min. and max. control signal values will equal the min. and max. stroke limits.  
In case the power to the actuator fails, after re-applying power, the actuator will acknowledge its present position and follow the signal from the controller. This makes it unnecessary for the actuator to employ autoadaptation in order to re-map the control signal settings.
- **"Y=0V"** (0 mA) is the default shipping position. When the rotation direction switch is set to this position, the actuator will run counterclockwise until the Y signal has attained its minimum value.
- **"Y=0V"** (0 mA): When the rotation direction switch is set to this position, the actuator will run clockwise until the Y signal has attained its minimum value.
- **"Service/Off"**: When the rotation direction switch is set to this position, all actuator rotary movement is cancelled and all control signals are ignored, thus enabling the actuator to be manually operated (see section "Manual Adjustment" on page 4). The user can then perform maintenance / commissioning without having to first remove power from the actuator. To return to the control mode, simply move the rotation direction switch to its former setting.

Table 1. Feedback/control signal values

rotation direction switch position	feedback/control signal when actuator is	
	totally ↺	totally ↻
Y=0V ↺*	U = 0 Vdc	U = 10 Vdc
Y=0V ↻	U = 10 Vdc	U = 0 Vdc

\*Default shipping position.

### Feedback Signal and Manual Adjustment

If, while the actuator is not rotating, the user declutches it and manually repositions the shaft adapter, the feedback signal will then follow the new position at which the shaft adapter has been left.

### Control Signal Offset Adjustment

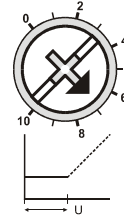

Fig. 4. Control signal offset switch

Use this adjustment to set the lower limit (U) of the control signal. The offset can be set to 0...10 Vdc.

### Control Signal Span Adjustment

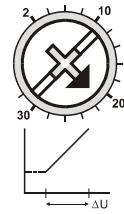

Fig. 5. Control signal span switch

Use this adjustment to vary the span ( $\Delta U$ ) of the control signal. The span can be set to 2...32 Vdc (**max. control range: 0...30 Vdc**). See also Fig. 6.

**NOTE:** The control signal must not exceed 30 V. Failing to observe this limitation could result in actuator damage.

### Example Cases

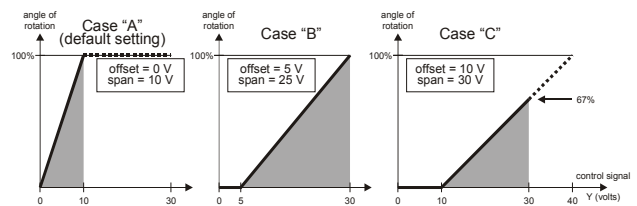

Fig. 6. Control signal input vs. angle of rotation

Case "A" (default shipping position): The control signal offset is set to 0 V and the control signal span adjustment to 10 V, as a consequence, a control input signal of 0...10 V results in an angle of rotation of 0...100%.

Case "B": The control signal offset is set to 5 V and the control signal span adjustment to 25 V; as a consequence, a control input signal of 5...30 V results in an angle of rotation of 0...100%.

Case "C": The control signal offset is set to 10 V and the control signal span to 30 V; as a consequence, a control map of 10...40 V for a control input signal of 10...30 V results in an angle of rotation of 0...67%.

### Dip Switches

The actuators are equipped with two dip switches accessible after removing the access cover (see Fig. 7).

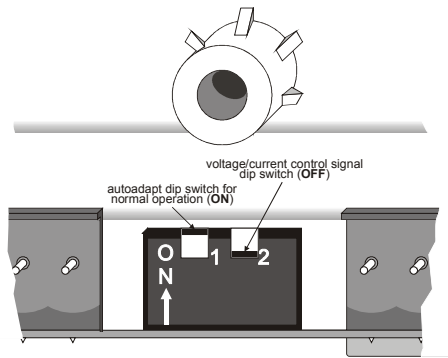

Fig. 7. Dip switches (view with PCB at bottom)

### Autoadapt Dip Switch for Normal Operation

In its default shipping position, the autoadapt dip switch for normal operation is set to **ON** as shown in Fig. 7. If it is set to OFF, no autoadapting is performed, and the control signal map remains constant.

The autoadapt functionality does not have to be triggered. Rather, the SmartAct actuator does this automatically when the min. and max. control signals are provided (see Fig. 8); the feedback signal is likewise autoadapted

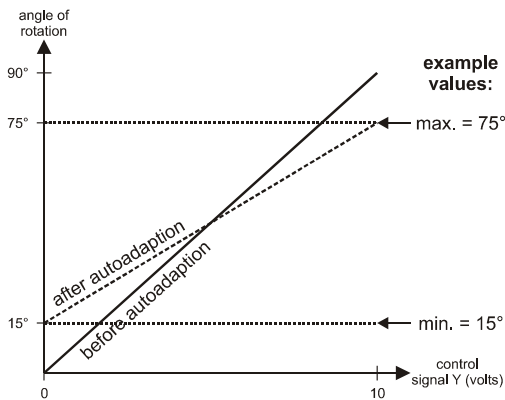

Fig. 8. Actuator positioning curve

### Adjusting the Actuator for Autoadapt

In order to make use of the autoadapt functionality, proceed as follows:

1. Set the autoadapt dip switch to the ON position.
2. If necessary, limit the stroke to the desired range using the mechanical end limits.
3. Drive the actuator to the left end limit (totally counter-clockwise) by setting the control signal as specified in Table 1.
4. Drive the actuator to the right end limit (totally clockwise) by setting the control signal as specified in Table 1. The stroke has now been limited to 0...100% of the control signal range.

### Voltage/Current Control Signal Selection Dip Switch

In its default shipping position, the voltage/current control signal dip switch is set to OFF (= voltage control) as shown in Fig. 7. Setting it to ON results in current control.

### Position Indication

The hub adapter indicates the rotation angle position by means of the rotational angle scales (0...90° / 90...0°).

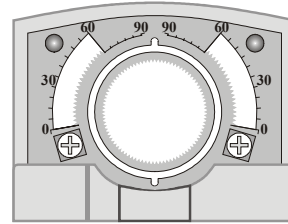

Fig. 9. Position indication

### Manual Adjustment

## IMPORTANT

To prevent equipment damage, you must remove power or set the rotation direction switch to the "Service/Off" position before manual adjustment.

After removing power or setting the rotation direction switch to the "Service/Off" position, the gear train can be disengaged using the declutch button, permitting the actuator shaft to be manually rotated to any position. The feedback signal will then follow the new position.

### Limitation of Rotation Stroke

Two mechanical end limits (adjustable in 3° increments) are provided to limit the angle of rotation as desired (see Fig. 10).

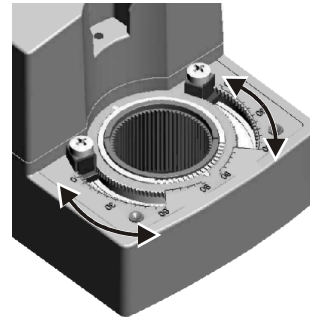

Fig. 10. Mechanical end limits

The mechanical end limits must be securely fastened in place as shown in Fig. 11. Specifically, it is important that they properly mesh with the rotational angle scales when the screws are tightened.

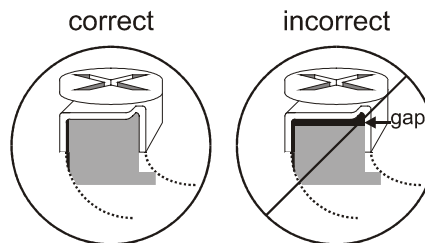

Fig. 11. Correct / incorrect tightening of end limits

## Internal Auxiliary Switches

**NOTE:** Only those actuators for which the option "-SW2" has been specified when ordering (e.g.: "N20010-SER-SW2") feature internal auxiliary switches.

The internal auxiliary switches are set to change from "common" to "normally open" at angles of 5° and 85°, respectively, from the totally counterclockwise position.

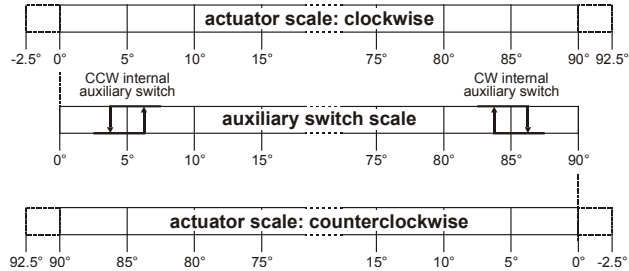

Fig. 12. Internal auxiliary switches

## Override

If terminal Y of the terminal strip (see section "Wiring Diagrams" on page 6) is unplugged, the stroke will be 0%; reversing the rotation direction using the rotation direction switch will result in a max. stroke of 100%. If terminal Y is jumped with terminal 1 (24 Vac), the stroke will be 50%.

## INSTALLATION

These actuators are designed for single-point mounting.

### IMPORTANT

In order to prevent equipment damage, you must remove power or set the rotation direction switch to the "Service/Off" position before manual operation.

## Mounting Instructions

All information and steps are included in the Installation Instructions supplied with the actuator.

## Mounting Position

The actuators can be mounted in any desired orientation (no IP54 if mounted upside down; see Fig. 13). Choose an orientation permitting easy access to the actuator's cables and controls.

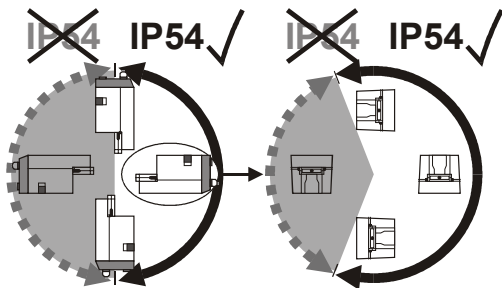

Fig. 13. Mounting for IP54

## Mounting Bracket and Screws

If the actuator is to be mounted directly on a damper shaft, use the mounting bracket and screws included in the delivery package.

## Self-Centering Shaft Adapter

The self-centering shaft adapter can be used for shafts having various diameters (10...27 mm [3/8...1-1/16"]) and shapes (square or round). In the case of short shafts, the shaft adapter may be reversed and mounted on the duct side.

## Stroke Limitation with Mechanical End Limits

The mechanical end limits enable the stroke to be limited from 0...90° in increments of 3°.

## Wiring

### Connecting to the Power Supply

In order to comply with protection class II, the power source of 24 V actuators must be reliably separated from the network power supply circuits as per DIN VDE 0106, part 101.

### Access cover

To facilitate wiring the actuator to the controller, the access cover can be detached from the actuator.

### IMPORTANT

Remove power before detaching the access cover. Once the access cover has been removed, please take care to avoid damaging any of the parts now accessible.



Fig. 14. Access cover (N20010-SER-SW2)

Depending upon the model, the access cover may have one or two terminal strips, including a layout with a description for each of the terminals.

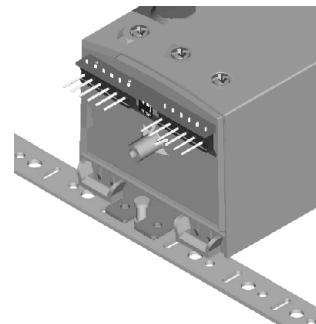
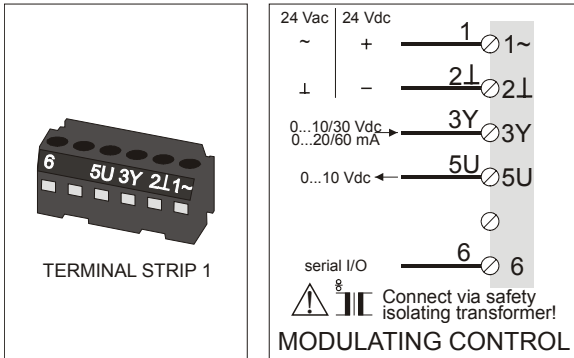

Fig. 15. N20010-SER-SW2 with access cover removed

## Wiring Diagrams

### N20010-SER



### N20010-SER-SW2

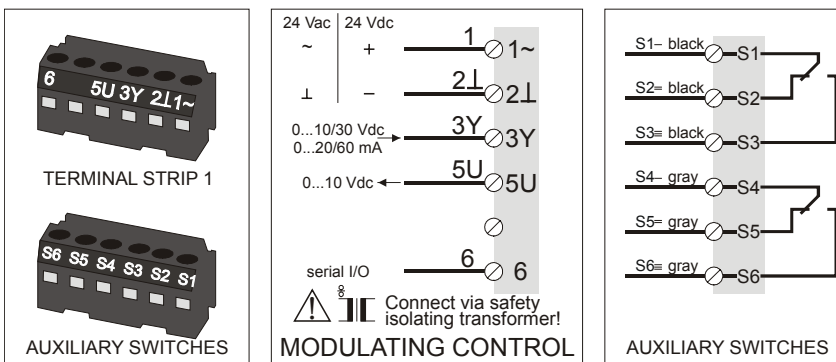

**NOTE:** Internal auxiliary switches S1 and S4 must be connected to the same power source.

connecting cable		wire print	terminal	name
supply and signal lines		1	1~	24 Vac~ / 24 Vdc+
		2L	2L	24 Vac⊥ / 24 Vdc-
		3Y	3Y	control signal
		5U	5U	position feedback signal 0(2)...10 V
		6	6	serial I/O
auxiliary switches (when included)	CCW (left) 5°	S1-	S1	common
		S2=	S2	normally closed
		S3=	S3	normally open
	CW (right) 85°	S4-	S4	common
		S5=	S5	normally closed
		S6=	S6	normally open



## DIMENSIONS

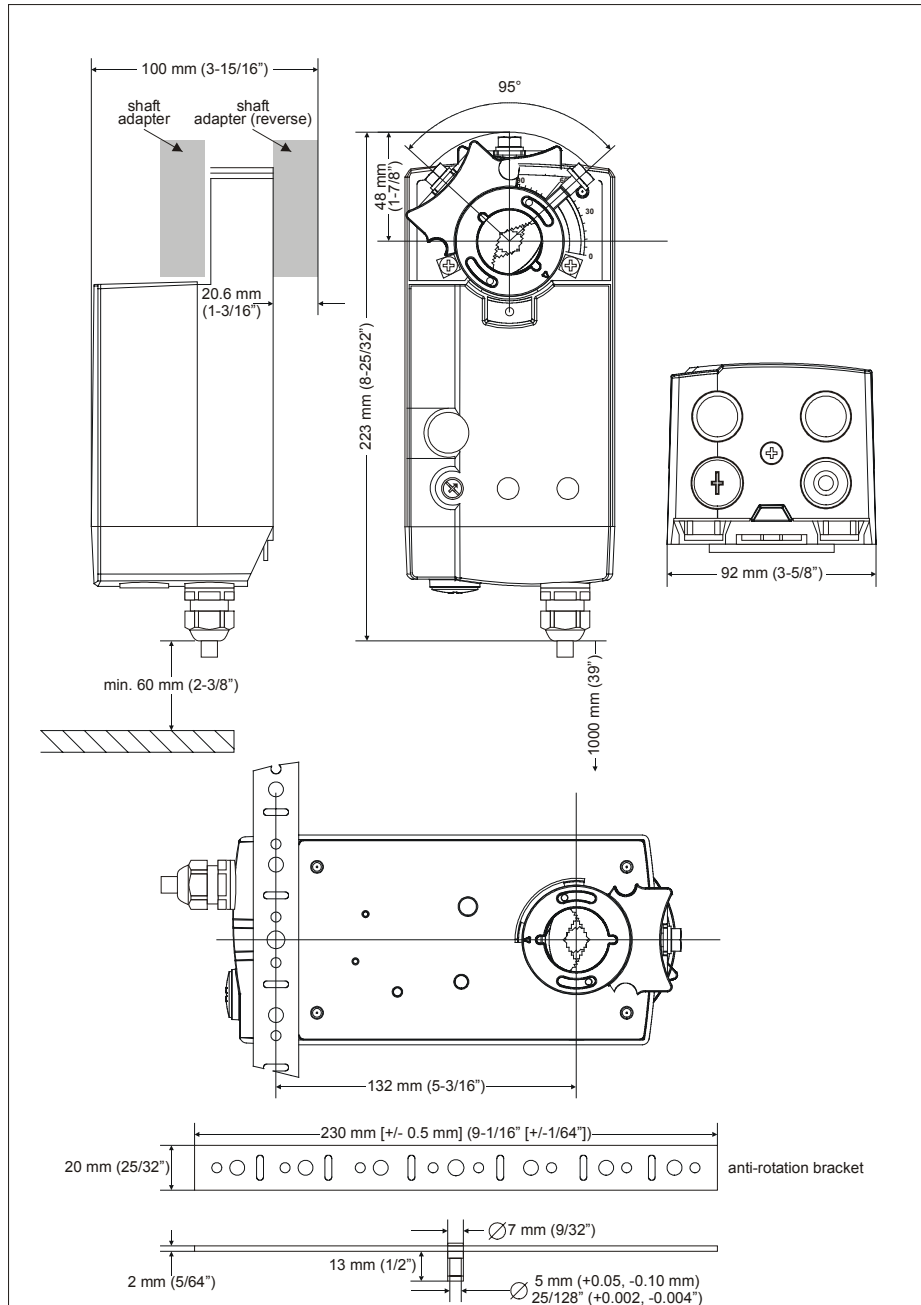

**Honeywell**

### Automation and Control Solutions

Honeywell GmbH  
 Böblinger Straße 17  
 D-71101 Schönaich  
 Phone: (49) 7031 63701  
 Fax: (49) 7031 637493  
<http://europe.hbc.honeywell.com>

Honeywell International Inc.  
 1985 Douglas Drive North  
 Golden Valley, MN 55422  
[www.honeywell.com](http://www.honeywell.com)

Subject to change without notice. Printed in Germany

Manufacturing location certified to **DIN EN ISO 9001**

EN0B-0342GE51 R0703  
 63-2589 A.B. 8-03