

Q5020A,C,D Globe Valve Linkages

FOR DIRECT COUPLED ACTUATORS

PRODUCT DATA



FEATURES

- Used with 2-way and 3-way globe valves in modulating or two-position service.
- Used with 27, 44, 88, and 175 lb-in. spring return and 35, 70, 175, and 300 lb-in. non-spring return DCA.
- Quick and simple installation with no disassembly required.
- Heavy-duty steel rack and pinion construction and aluminum die-cast housing.
- Maintenance-free construction.
- Precision roller-bearing rack construction prevents premature valve packing wear and leakage.
- Flexible actuator mounting orientation.
- Adjustable manual override lever and valve position indicator.
- Can be mounted on specific non-Honeywell valves using a 32004629 bonnet adapter kit.

APPLICATION

Q5020 globe valve linkages connect a Honeywell direct coupled actuator (DCA) to a steam or water globe valve. Q5020 linkages are compatible with 2- and 3-way globe valves.

Contents

Application	1
Specifications	2
Installation	6
Checkout	8



SPECIFICATIONS

Models: See Table 2.

Dimensions: See Fig. 1.

Temperature Range:

Ambient Range: -40°F to 140°F (-40°C to 60°C).

Medium Range: 32°F to 337°F (0°C to 169°C).

Actuator Required: See Table 3 for valve-actuator combinations.

Close-off Ratings:

Threaded Valves: See Table 4.

Flange Valves: See Table 5.

Materials of Construction:

Housing: Die-cast aluminum.

Rack and Pinion Gears: Steel and powdered metal.

Manual Override Lever: Steel.

Accessories:

32004629-001 Bonnet Adapter Kit for 1/2 to 3 in. Siemens Globe Valves.

32004629-002 Bonnet Adapter Kit for 1/2 and 3/4 in. Johnson Globe Valves.

32004629-003 Bonnet Adapter Kit for 1 to 2 in. Johnson Globe Valves.

32004629-004 Bonnet Adapter Kit for 1/2 to 2 in. Siebe Globe Valves.

Table 1. Q5020 bag assembly.

32003000-001 bag assembly components	Quantity
220851 (nut and washer)	5
220846 (bolt .25-20x.50)	2
32002575-001 (U-bolt, lever)	1
40003698-001 (U-bolt, linkage)	1
14004623-001 (stem button)	1
32002571-001 (lever)	1
50089665-001 (anti-rotation pin)	1
50089666-001 (anti-rotation pin)	1

NOTE: Some of the components will be left over after the linkage is installed.

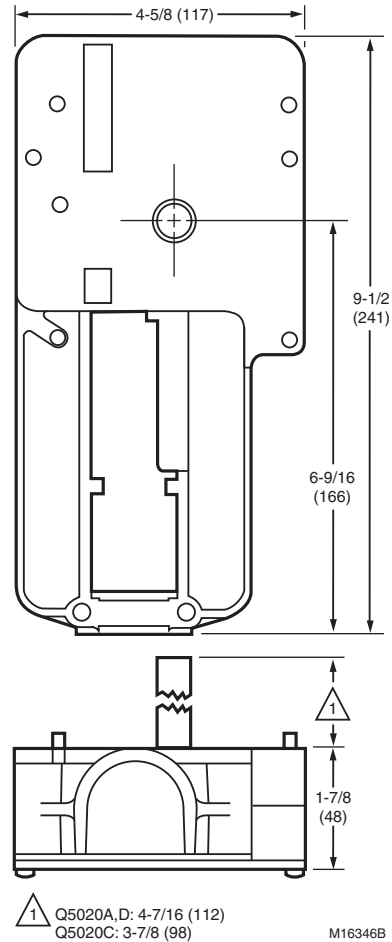

Fig. 1. Q5020 dimensions in in. (mm).

ORDERING INFORMATION

When purchasing replacement and modernization products from your TRADELINE® wholesaler or distributor, refer to the TRADELINE® Catalog or price sheets for complete ordering number. If you have additional questions, need further information, or would like to comment on our products or services, please write or phone:

1. Your local Honeywell Environmental and Combustion Controls Sales Office (check white pages of your phone directory).
2. Honeywell Customer Care
1885 Douglas Drive North
Minneapolis, Minnesota 55422-4386
3. <http://customer.honeywell.com> or <http://customer.honeywell.ca>

International Sales and Service Offices in all principal cities of the world. Manufacturing in Belgium, Canada, China, Czech Republic, Germany, Hungary, Italy, Mexico, Netherlands, United Kingdom, and United States.

Table 2. Q5020 models.

Model	Stroke ^a (in.)	Shaft (in.)	Compatible valve sizes (in.)	Compatible DCA torque (lb-in.)
Q5020A	3/4	1/2	1/2 to 3	27 to 300 (spring and non-spring return)
Q5020C ^b	1-1/2	1	2-1/2 to 6 (V5051)	175 (spring return) or 300 (non-spring return)
Q5020D	1/2	1/2	See Table 3	27 to 300 (spring and non-spring return)

^a Applies to Q5020 and compatible valves.

^b Includes 43196000-001 bonnet adapter and 311851 stem extension.

Table 3. Acceptable Q5020 linkage, Honeywell valve, actuator combinations.

Valve						Actuator torque (lb-in.)				
Body	Required bonnet adapter kit	Model	Connection	Size (in.)	Stroke (in.)	Non-spring return			Spring return	
						35/70 and 44/88	175	300	27/44 and 44/88	175
Honeywell valves										
Globe	None	V5011, V5013	NPT	1/2 to 3	3/4	Q5020A	Q5020A	Q5020A	Q5020A	Q5020A
		V3350, V3351, V3360, V3361, V3450, V3451, V3460, V3461	Flanged	2 1/2 to 3 ^a						
Double-seated	None	V5047	NPT	1/2 to 3	9/16 to 3/4					
Cage	None	V5051 ^b	Flanged	2-1/2 to 6	1-1/2	—	Q5020C	Q5020C	—	Q5020C
Siemens (Landis, Powers) valves										
Globe	32004629-001	Flowrite 599 Series	NPT	1/2 to 2	3/4	Q5020A and actuator to provide required torque ^c				
			Flanged	2 1/2 to 3						
Johnson Controls valves										
Globe	32004629-002	VG7000	NPT	1/2 to 3/4	5/16 ^c	Q5020D	Q5020D	—	Q5020D	Q5020D
	32004629-003			1 to 1 1/4	1/2	Q5020A and actuator to provide required torque ^d				
				1 1/2 to 2	3/4					
Siebe (Barber Coleman) valves										
Globe	32004629-004	VB7000	NPT	1/2 to 2	1/2	Q5020D	Q5020D	—	Q5020D	Q5020D

^a Single-seated flange valves larger than those shown require an ML6421B or ML7421B direct coupled valve actuator.

^b Must use the bonnet adapter and stem extension supplied with the linkage.

^c Use of a Q5020D (1/2 in. stroke) with a 5/16 in. stroke Johnson Controls valve allows the DCA hub to rotate only approximately 56° (not the full 90° stroke). This results in the use of only 2/3 of the control signal through the full valve stroke. For modulating applications this reduces control resolution. For two-position applications reduced accuracy is not an issue.

^d Close-off ratings with Q5020 linkages and non-Honeywell valves are not included in this document. This value must be approximated using the Honeywell close-off rating information in Tables 4 and 5 as a reference. For example, an assembly with a 2 in. V5011N ($C_v = 46.8$) and a Q5020A with a 75 lb-in. non-spring return DCA provides 53 psid close-off. Using the same actuation package on a similar valve ($C_v = 40$) results in a close-off rating of approximately 62 psid ($46.8/40 * 53 = 62$). However, there are many other factors involved in determining close-off ratings, so this method supplies only an approximation.

Table 4. Threaded valve close-off pressure (psid)^a.

Honeywell valve					Honeywell actuator torque (lb-in.)										
Medium	Valve type	Model family	Size (in.)	Flow capacity (Cv)	Fail-in-place					Spring return					
					35	44	70	88	175	300	44	88	175		
Water	2-way	V5011N1, V5011N3	0.50	0.73	230	230	230	230	230	230	230	230	230	230	
				1.16	230	230	230	230	230	230	230	230	230		
				1.85	230	230	230	230	230	230	230	230	230		
				2.9	230	230	230	230	230	230	230	230	230		
				4.7	143	188	230	230	230	230	184	230	230		
			0.75	7.4	69	91	156	192	230	230	79	150	230		
			1.00	12	47	63	109	135	230	230	66	136	230		
			1.25	16	29	39	69	85	168	230	40	84	171		
			1.50	29	17	24	44	55	113	180	26	55	113		
		2.00	47	8	17	24	30	63	103	13	30	63			
				V5011F	2.50	63	5	7	16	19	42	74	9	21	45
					3.00	100	2	3	9	11	26	45	6	13	27
Steam	2-way	V5011N2	0.50	0.73	100	100	100	100	100	100	100	100	100		
				1.16	100	100	100	100	100	100	100	100	100		
				1.85	100	100	100	100	100	100	100	100	100		
				2.9	100	100	100	100	100	100	100	100	100		
				4.7	100	100	100	100	100	100	100	100	100		
			0.75	7.4	69	91	100	100	100	100	79	100	100		
			1.00	12	47	63	100	100	100	100	66	100	100		
			1.25	16	29	39	69	85	100	100	40	84	100		
			1.50	29	17	24	44	55	100	100	26	55	100		
		2.00	47	8	17	24	30	63	100	13	30	63			
				V5011G	2.50	63	5	7	16	19	42	74	9	21	45
					3.00	100	2	3	9	11	26	45	6	13	27
Water	3-way	V5013N	0.50	2.9	230	230	230	230	230	230	230	230	230		
				4.7	143	188	230	230	230	230	184	230	230		
			0.75	7.4	69	91	156	192	230	230	79	150	230		
			1.00	12	47	63	109	135	230	230	66	136	230		
			1.25	16	29	39	69	85	168	230	40	84	171		
			1.50	29	17	24	44	55	113	180	26	55	113		
			2.00	47	8	17	24	30	63	103	13	30	63		

^a Check valve pressure ratings for the application.

NOTE: Close-off ratings are worst-case conditions; the actual values may be higher.

Table 5. Flanged valve close-off pressures (psid)^a

Honeywell valve					Honeywell actuator torque (lb-in.)					
Medium	Valve type	Model family	Size (inch)	Flow capacity (Cv)	Fail-in-place				Spring return	
					70	88	175	300	88	175
Water	2-way	V5011A	2.5	63	21	27	52	88	27	56
			3	100	9	11	24	42	11	25
		VGF21ES, VGF21LS, VGF22ES	2.5	70	18	34	52	77	33	71
			3	115, 125, 120	9	16	26	38	15	35
		VGF21EP, VGF21LP	2.5	70	–	–	175	175	–	175
3	115, 120		–	–	175	175	–	175		
Steam	2-way	V5011A	2.5	63	15	15	15	15	15	15
			3	100	9	11	15	15	15	15
		VGF21ES, VGF21LS, VGF22ES	2.5	70	–	–	52	77	–	71
			3	115, 125, 120	–	–	26	38	–	35
		VGF21EP, VGF21LP	2.5	70	–	–	100	100	–	100
			3	115, 120	–	–	100	100	–	100
		V5051 (requires Q5020C)	2.5	75	–	–	–	50	–	50
			3	116	–	–	–	50	–	50
			4	178	–	–	–	50	–	50
			5	318	–	–	–	50	–	50
Water	3-way	V5013B, V5013C	2.5	63	21	27	52	88	27	56
			3	100	9	11	24	42	11	25
		VGF31EM, VGF32EM	2.5	70	23	44	66	97	43	89
			3	120, 115	15	29	44	65	28	59
		VGF31LD, VGF32LD	2.5	70	18	34	52	97	33	71
			3	120	9	16	26	65	15	35

^a Check valve pressure ratings for the application.

NOTE: Close-off ratings are worst-case conditions; the actual values may be higher.

INSTALLATION

When Installing this Product...

1. Read these instructions carefully. Failure to follow them could damage the product or cause a hazardous condition.
2. Check the ratings given in the instructions and on the product to make sure that the product is suitable for your application.
3. Installer must be a trained, experienced service technician.
4. After installation is complete, check out product operation as provided in these instructions.

Location

Select a location in which the valve, linkage, and motor will be within the environmental and ambient temperature ratings. See the Specifications section.

NOTE: Allow approximately 12 in. clearance above the valve bonnet for installation and servicing.

Mounting

IMPORTANT

1. Ensure the valve stem stroke matches the Q5020 linkage. See Table 2.
2. Mounting the Q5020 on a non-Honeywell valve requires the correct bonnet adapter kit. See Table 3.

Preparation

When using a high-torque actuator (175 lb-in. or greater torque) a steel stem button is required. If the valve stem button is brass, replace the brass stem button with the provided steel stem button:

1. Measure the stem button height (from the valve bonnet to the top of the button).
2. Loosen the set screw of the brass stem button.
3. Remove and discard the brass stem button.
4. Install the steel stem button.
5. Ensure the stem button height is the same as in step 1.
6. Tighten the set screw of the steel button.

Installation

1. Ensure the valve stem operates freely. Impaired stem operation can indicate a twisted valve body or a bent stem. Either of these conditions can require valve replacement.
2. Place the Q5020 linkage over the valve bonnet while fitting the rack slot onto the valve stem button.

NOTE: For V5051 valves, first install bonnet adapter and stem extension (see Fig. 4).

3. Ensure the linkage installs flush on the valve bonnet.

IMPORTANT

To ensure even pressure on the valve bonnet, first tighten the nuts finger-tight and then alternate turning each U-bolt nut until both are tight.

4. Assemble and tighten the U-bolt and nuts. When using a 35 or 70 lb-in. non-spring return actuator, discard the mounting plate and proceed to step 7.

NOTE: A 35 or 70 lb-in. non-spring return actuator fits between raised tabs in the cast housing to prevent rotation, eliminating the need for the mounting plate.

5. Using the included 3/4 in. long bolts, attach the actuator mounting plate to the housing so that it protrudes to either the left or the right side of the linkage, whichever is the more convenient for installation. See Fig. 2.

IMPORTANT

Take care not to over-tighten the screws and strip the threads.

6. Attach the anti-rotation hardware to the actuator mounting plate. See Fig. 3 through 5.

NOTE: The Q5020 ships with bracket and two pins to accommodate different actuators. Install the hardware compatible with your actuator. See Table 6 for the reference.

7. Put the actuator in place over the shaft but do not tighten the actuator hub screws.
8. Verify that the valve stem stroke direction and actuator rotation direction are properly related. For example, assume a spring return actuator and a 2-way, stem-down-to-close, normally-closed valve are used together. With an unpowered actuator, the valve should be fully closed. To accomplish this rotate the Q5020 shaft fully counterclockwise (as viewed from the front). This moves the valve stem fully downward so that rotating the shaft counterclockwise closes the valve.
9. Install the manual override handle on the linkage shaft. Tighten the nuts on the U-bolt. Rotate the handle to check the full stroke of the valve stem for smooth movement and handle clearance.

NOTE: The handle can aid in visualizing the valve position. Attach the handle perpendicular to the piping with the valve closed. This should position the handle parallel to the piping with the valve open.

NOTE: Torque to tighten the nut in the pin is 120 +/- 2 lb-in.

10. Set the valve and the linkage to the normal position. Note the valve stem position (up or down) for the next step:
 - a. 2-way valve: use the handle to fully close the valve.
 - b. 3-way valve: use the handle to fully close the valve to either seat.
11. Install the actuator approximately five degrees from its end stop with the valve fully seated. This ensures that the actuator closes the valve before it reaches its end-stop.
 - a. Valve stem fully down: actuator must be five degrees from the counterclockwise end stop.
 - b. Valve stem fully up: actuator must be five degrees from the clockwise end stop.
12. Position the actuator on the Q5020:
 - a. When using a 35 or 70 lb-in. actuator, ensure that the actuator is flush with the Q5020 housing, and located between the raised tabs.
 - b. For all other actuators, position the actuator approximately parallel to the mounting plate.
13. Tighten the actuator hub to the linkage shaft and install actuator control wiring. See the instructions provided with the actuator.

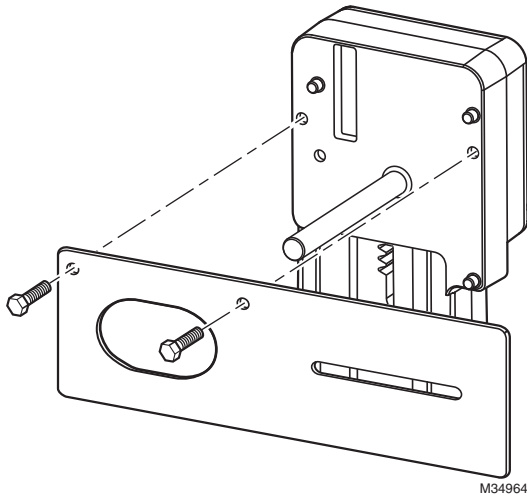

M34964

Fig. 2. Installing actuator mounting plate to Q5020.

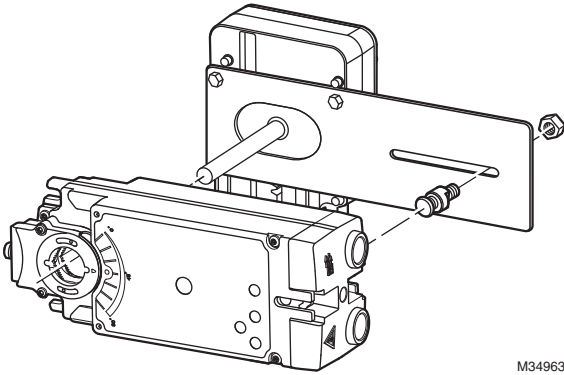

M34963

Fig. 3. Typical installation of direct coupled actuators.

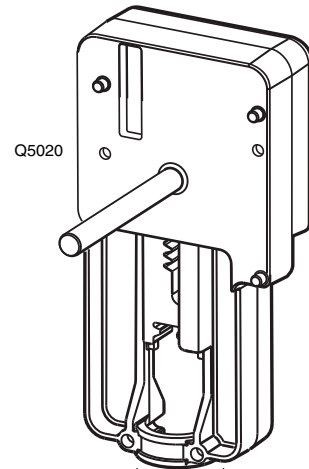

Q5020

43196000-001

STEM BUTTON

311851

THE EXTENSION IS DRILLED TO ACCEPT A 1/16 IN. DRIFT PIN TO ASSIST IN TIGHTENING.

VALVE STEM

VALVE BONNET

M20531

Fig. 4. Installing bonnet adapter and stem extension to V5051.

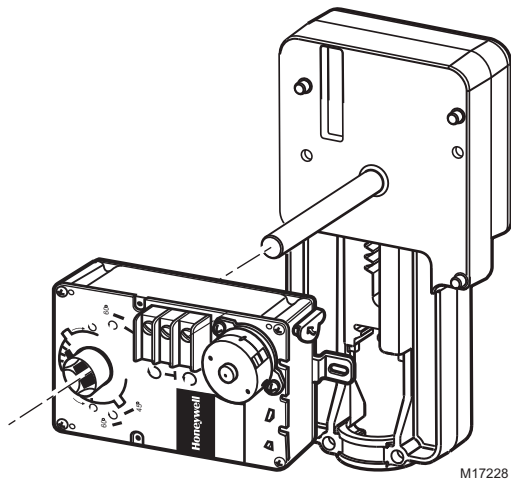

Fig. 5. Installing 35 or 70 lb-in. actuator.

CHECKOUT

After installing the linkage and the actuator, proceed as follows:

1. Apply power to the actuator.
2. Cycle the valve through at least one complete stroke to ensure proper operation.
3. Ensure that the valve sits before the actuator reach the stroke end.

NOTE: For 3-way valves it is important to make sure that the plug sits properly on both the upper and the lower seats before the actuator reaches either end of its full stroke.

4. If the valve does not travel or seat properly and is installed correctly, check Tables 3, 4, and 5. Ensure the valve, actuator, and linkage combination is correct for your application.
5. If the preceding troubleshooting steps do not locate the problem, check both the actuator and valve individually (see Checkout sections of the device instructions). For example, the actuator stroke may be impeded or the valve stem button height may be out of adjustment.
6. If the valve and actuator operate properly but the valve, actuator, and linkage combination does not, replace the linkage.

Table 6. Anti-rotation assemblies' accessories

Actuator	Torque	Bracket	Pins
Spring return			
MS4103, MS8103, MS7503, MS7403, MS3103	27 lb-in	32002572-002	50089666
MS4105, MS8105, MS7505, MS7405, MS3105	44 lb-in		
MS7510, MS8110, MS4110	88 lb-in		
MS4120, MS8120, MS7520	175 lb-in		
Non-spring return			
MN6105, MN7505	44 lb-in	32002572-002	50089665
MN6110, MN7510	88 lb-in		
MN6120, MN7220	175 lb-in		
MN6134, MN7234	300 lb-in		
ML6161, ML7161	35 lb-in	No bracket	No pin
ML6174, ML7174	70 lb-in	No bracket	No pin

Automation and Control Solutions

Honeywell International Inc.
 1985 Douglas Drive North
 Golden Valley, MN 55422
 customer.honeywell.com

