

# VBF2, VBF3 Control Ball Valves With Flanged Connections

## SPECIFICATION DATA

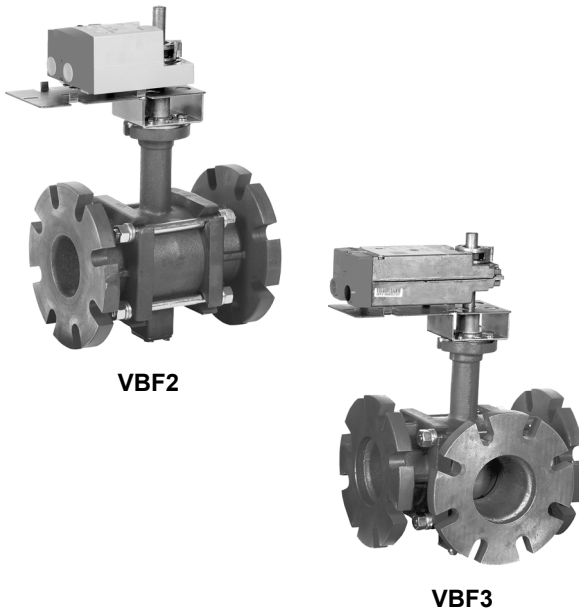

## FEATURES

### All Models

- Sizes from 4 to 6 inch with ANSI Class 125 flanged connections.
- Equal percentage or linear flow characteristics.
- Choice of four, factory-installed actuation control schemes: Floating, Modulating (2-10 V), Spring Return 24V 2-Position, Spring Return Modulating/Floating.
- Field configurable for normally open or normally closed fail-safe position.
- ANSI Class IV leakage specification (0.01% of  $C_V$ ).
  - 2-way - ANSI Class IV leakage
  - 3-way - A to AB; ANSI Class IV leakage
  - 3-way - B to AB; ANSI Class III leakage
- Optional NEMA 3R (IP54) rated enclosure for outdoor applications.
- Option of four actuator mounting positions on the valve.
- Wide range of  $C_V$  choices from 91 to 650.
- Valve ball and stem 316 stainless steel.

### VBF3 (Three-way)

- Mixing or Diverting control.
- Globe valve A-B-AB flow pattern (side B port)

## APPLICATION

The VBF2 Two-Way and the VBF3 Three-Way Ball Valve Assemblies, with and without actuators, control hot and chilled water with glycol solutions up to 50% in heating, ventilating, and air conditioning (HVAC) systems to provide two-position or modulating functions.

These valve assemblies can be ordered with or without factory-mounted non-spring return or spring return direct-coupled actuators (DCA).



# SPECIFICATIONS

**Table 1. Model Selection.**

Valve	Fitting	Body /Flow	Size	C <sub>V</sub>	T/P	Trim	Enclosure	Actuator
VB = valve, ball								
F = Flanged								
2 = 2 way								
3 = 3 way								
inch S.I. metric								
J 4 DN100								
K 5 DN125								
L 6 DN150								
S								
T								
U								
1								
2								
3								
4								
5								
6								
7								
1 = ANSI Valve construction								
S = Stainless Steel								
0 = no enclosure								
R = NEMA 3R enclosure								
X = no actuator								
A = NSR, Floating								
B = NSR, Modulating								
C = SR, 2-Position, 24 Vac								
D = SR, Floating/Modulating								
VB	F	2	A	B	1	S	0	A

**Dimensions:** Refer to Figures 1 and 2.

**Body Style:** Two-way ball valve, straight-through flow, full or reduced port using laser-milled stainless steel control ball. Three-way ball valve, A-B-AB characterized flow, laser-milled stainless steel control ball.

Combination ANSI 125/PN16 flanged connections.

**Body Size:** 4 to 6 inch (DN100, DN125, DN150).

**Flow Capacity:** See Table 2.

**Body Pressure Rating (maximum):**  
240 psi (1655 kPa) at 250° F (121° C).

**Controlled Medium:** Water or Glycol solutions up to 50%.  
Not suitable for combustible gases.

**Fluid Temperature Range:** -22 to +250° F (-30 to +121° C).

**Maximum Differential Pressure:** Refer to Table 3.

**Flow Characteristics:**

Two-way: Equal Percentage.

Linear with full port.

Three-way: Port A to AB: Equal Percentage.

Port B to AB: Linear with 20% reduced flow capacity.

**Rangeability:** 500:1 minimum.

**Mounting:** Bolt holes conform to ANSI B16.1.

**Materials:**

Body: Cast Iron ASTM A395, 60-40-18

Ball and Stem: 316 Stainless Steel.

Stem Seals: EPDM O-Rings.

Ball Seals: Teflon® Seals

**Approvals/Standards:**

Valves: ANSI Class IV close-off/leakage (A port only).

2-way - ANSI Class IV leakage

3-way - A to AB; ANSI Class IV leakage

3-way - B to AB; ANSI Class III leakage

Actuators: Non-Spring Return, Floating or Modulating

UL/cJUL.

UL873 Plenum Rating, File No. E4436; Guide No. XAPX.

CE

Spring Return 2-Position, 24 Vac or Floating/Modulating

UL/cJUL

UL873 Plenum Rating, File No. E4436; Guide No. XAPX.

CE

C-TICK

**Accessories:**

7981-200 replacement mounting kit for Honeywell® direct coupled actuators.

SW2-US actuator auxiliary switch kit.

**Table 2. Flanged Valves C<sub>V</sub> Values.**

Pipe Size	C <sub>V</sub> Designator*									
	S	T	U	1	2	3	4	5	6	7
4 in.	91	118	152	197	254	327 <sup>a</sup>				
5 in.			144	185	240	309	400			
6 in.				208	268		346	441	577	650

<sup>a</sup> For three-way valves only

\* Maximum flow is 700 gpm (44 L/s)

## Application Notes

### Required Torque

Both Honeywell non-spring return and spring return direct coupled actuators can be utilized with the VBF2 and VBF3 valves. See Table 3, which lists the close-off pressure rating for the valves with the different torque actuators. Larger torque actuators may be used, but there is no increase in close-off pressure rating.

**Table 3. Close-off Pressure Ratings**

Valve Size	Actuator Torque			
	88 in.-lb (10 Nm)	175 in.-lb (20 Nm)	175 in.-lb (20 Nm) 2-position	300 in.-lb (34 Nm)
Close Off Pressure Rating (psid)				
4 in.	70*	130	130	130
5 in.	70*	130	130	130
6 in.			70*	70*

\* This is the factory-installed actuator rating.

### Flow Characteristics

VBF2 Two-Way Ball Valves have:

- an equal percentage flow characteristic.

VBF3 Three-Way Ball Valves have:

- between ports A and AB: an equal percentage flow characteristic.
- between ports B and AB: a linear flow characteristic.

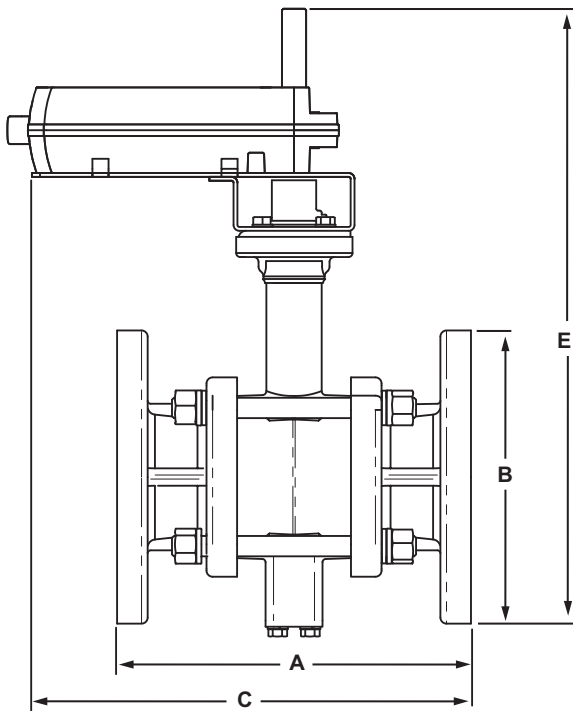

Size (in.)	Model Number	A in. (mm)	B in. (mm)	C in. (mm)	D (depth) (not shown) in. (mm)	E in. (mm)	Wt. lb (kg)
4	VBF2J	11 (278)	9 (229)	13-1/4 (337)	9 (229)	18-3/4 (476)	65 (31)
5	VBF2K	12-3/8 (352)	10 (254)	14-1/4 (362)	10 (254)	19 (483)	75 (34)
6	VBF2L	13-7/8 (352)	11 (278)	15-1/8 (384)	11 (278)	19-7/8 (505)	90 (41)

M113732

**Fig. 1. VBF2 Dimensions in inches (mm).**

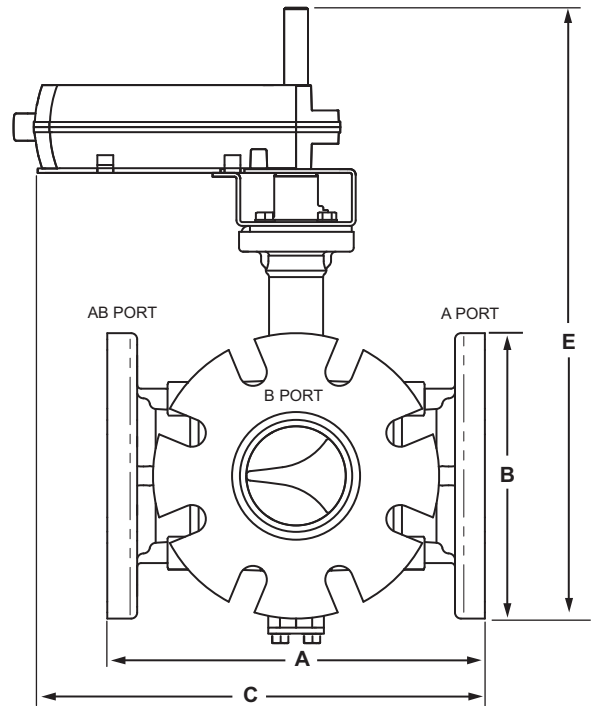

Size (in.)	Model Number	A in. (mm)	B in. (mm)	C in. (mm)	D (depth) (not shown) in. (mm)	E in. (mm)	Wt. lb (kg)
4	VBF3J	11-7/8 (278)	9 (229)	14-1/8 (337)	10-3/8 (229)	18-1/2 (470)	75 (34)
5	VBF3K	13-7/8 (352)	10 (254)	15-1/8 (362)	12 (254)	19-3/8 (483)	90 (41)
6	VBF3L	15-7/8 (403)	11 (278)	16-1/8 (410)	13-3/8 (521)	20-1/2 (521)	105 (48)

M113733A

**Fig. 2. VBF3 Dimensions in inches (mm).**

## TYPICAL SPECIFICATIONS

### Actuated Ball Valve

Valve housing shall consist of cast iron, rated at no less than 240 psi at 250° F (121° C). Valve housing shall have ANSI Class 125 flanges. Valve ball shall consist of stainless steel with parabolic ports to make flow control equal percentage. Valve shall have a blow-out proof stem with two EPDM O-Rings. Valve shall have EPDM O-Rings behind ball seals to allow for a minimum close-off pressure of 70 psi with 88 in.-lbs of torque for 4 and 5 inch valves. Six inch valves shall require actuators with 140 in.-lbs of torque for flow rates under 700 gpm. Valve shall be available with a minimum of 5 unique  $C_V$  values for each size. 3-Way Valve: Bypass  $C_V$  shall be 80% of Through  $C_V$ .

*Honeywell® is a registered trademark of Honeywell International.*

*Teflon® is a registered trademark of E I DuPont de Nemours.*

### Valve Actuator

Control valve actuator shall accept analog modulating floating (tri-state), or two-position signal as indicated in the control sequence. Actuators shall be by Honeywell. Actuator shall provide minimum torque required for full valve shutoff position. Wiring terminals shall be provided for installation to control signal and power wiring.

### ACCESSORIES

Identification tags shall be available for all valves; tags shall be indelibly marked with  $C_V$ , model number and location.

### Automation and Control Solutions

Honeywell International Inc.  
1985 Douglas Drive North  
Golden Valley, MN 55422

Honeywell Limited-Honeywell Limitée  
35 Dynamic Drive  
Toronto, Ontario M1V 4Z9  
customer.honeywell.com

© U.S. Registered Trademark  
© 2011 Honeywell International Inc.  
62-3078—04 M.S. Rev. 05-11  
Printed in U.S.A.

# Honeywell