

SmartVFD Two Contactor Bypass Assemblies

INSTALLATION INSTRUCTIONS

APPLICATION

Two Contactor Bypass

The SmartVFD Two Contactor Bypass Assemblies channel electrical power either through or around the variable frequency drive (VFD).

INSTALLATION

When Installing This Product

1. Read these instructions carefully. Failure to follow them could damage the product or cause a hazardous condition.
2. Check the ratings given in the instructions, Honeywell SmartVFD manual and on the product to make sure the product is suitable for your application.
3. Verify bypass model is correct; no damage has been incurred; no screws, connections, terminations are loose.
4. Installer must be a trained, experienced service Technician, with VFD operation experience.
5. After installation is complete, check out product operation as provided in these instructions.



WARNING

Can Cause Serious Injury or Death.

1. Installation requires work with voltages that may cause serious injury or death.
2. This instruction manual is intended as a guide only. End user is responsible for proper application of this assembly, insuring proper conformance, directives, intended use and maintaining all safety practices as described in Honeywell SmartVFD manual, local codes, local safety authorities.
3. Disconnect power supply before installation, and before any servicing.



CAUTION

Equipment Damage Hazard.
Can short equipment circuitry.
Disconnect power supply before installation.

Location and Mounting

Locate the device in a clean, dry, well-ventilated area with an ambient temperature below 104°F (40°C).

Refer to SmartVFD manual Installation chapter for free air space requirements above and to the sides of SmartVFD's.

Ensure proper branch/short circuit protection is provided.

WIRING

IMPORTANT

All wiring must agree with applicable codes, ordinances and regulations.

Variable frequency drive can store energy. Refer to VFD manual for safe work practices and appropriate wait times before servicing after equipment power has been de-energized.

All safety, warning and caution information located in Honeywell SmartVFD manual must be read, understood and followed.

Before proceeding, make sure proper branch/short circuit protection has been provided (see SmartVFD manual).

1. Ensure that bypass panel voltage corresponds with that of the power supply.
2. To access the bypass panel wiring compartment:
 - a. Ensure the customer supplied main disconnect handle or circuit breaker is in the OFF position.
 - b. Open the cover.
 - c. Test for power.
3. Refer to SmartVFD manual "Cabling and Connections" for proper power and control wire sizing information.
4. Terminate input three phase power wiring to line terminals: "L1", "L2", "and "L3". Refer to bypass panel schematic.
5. Terminate three phase motor wiring to motor terminals "T1", "T2", "T3". Refer to bypass panel schematic.
6. Terminate all VFD control wiring to the proper terminals in the bypass panel. Refer to bypass panel schematic.
7. Leave jumper J1 on bypass panel terminals 1 & 3 if fire/smoke/safety shutdown is not used. If this shutdown is used, remove jumper J1 and terminate to bypass panel terminals 1 & 3.

Refer to schematic for typical wiring.

IMPORTANT

Use only copper wire with 167°F (75°C) minimum.



OPERATION

1. Make sure bypass panel and motor are properly grounded.
2. Make sure all connection points are tight, including all bypass panel connection points.
3. Make sure all safeties (customer option) are connected and in working order.
4. Double check correct voltage is being applied and power and motor wiring are terminated in the correct place.
5. Verify motor FLA does not exceed VFD output amp rating and bypass starter overload relay setting dial.
6. Set bypass starter overload relay adjustment dial to motor FLA.
7. Verify building automation system is ready for start, stop, speed command; all wires are terminated in the correct location.
8. Make sure all personnel, debris, etc are clear.

Before applying power verify customer supplied main input disconnect handle or circuit breaker is in the “OFF” position; “Bypass/Off/VFD” selector switch is in the “OFF” position.

1. Apply input power.
2. Check three phase voltage on line terminals: “L1”, “L2”, “and “L3”.
 - a. Turn “Bypass/Off/VFD” selector switch to “VFD” position. Press “Loc/Rem” button and program correct parameters for local (keypad) control. See SmartVFD manuals. Check motor rotation.
 - b. If motor is rotating backwards in VFD mode, shut down power, lock out power source, wait until VFD stored energy has dissipated, switch incoming motor wires on the “T1” and “T2” terminals in the bypass panel, or motor wires “T1” and “T2” in the motor junction box. Re-energize power and check rotation again.
3. Turn “Bypass/Off/VFD” selector switch to “Off” position. Wait for motor to stop. Turn selector switch to “Bypass” position then back to “Off” position. Do not leave the motor running in “Bypass” position. Check motor rotation.
 - a. If motor is rotating backwards in Bypass mode, shut down power, lock out power source, test incoming voltage on incoming line power wiring on line termi-

nals “L1”, “L2”, “L3”. Once it is established that power is shut down, swap incoming wires on terminals “L1” and “L2”. Re-energize power and check rotation again.

Bypass panel “Bypass/Off/VFD” selector switch has three operating positions:

1. VFD: Device directs power to VFD first, then to the motor. VFD controls the motor as it would without the bypass panel.
2. OFF: Device stops power. Power reaches neither the motor nor the VFD.
3. BYPASS: Device directs power to motor only. No power reaches the VFD. The motor operates at full speed with full power.

Operation Using the VFD (VFD Position)

To set bypass panel to use VFD to control the motor as it would without the bypass panel:

1. Stop the motor.
2. Wait five seconds.
3. Rotate switch to VFD.
4. Start the VFD (see VFD instructions for details).

VFD Bypass

To set bypass panel to direct power only to motor:

1. Rotate switch from VFD to OFF.
2. Wait five seconds.

IMPORTANT

Switching the bypass panel to BYPASS can immediately turn the motor on.

3. Rotate switch to BYPASS.

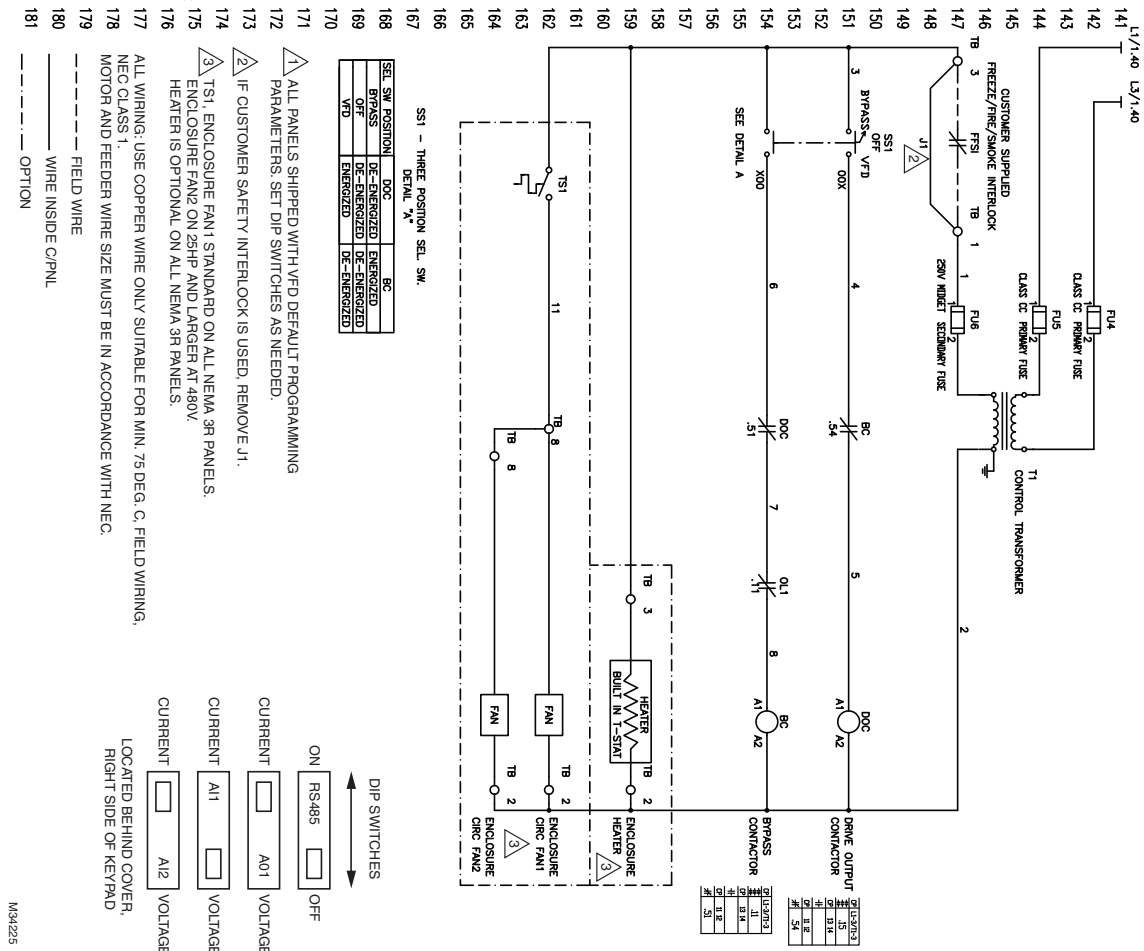
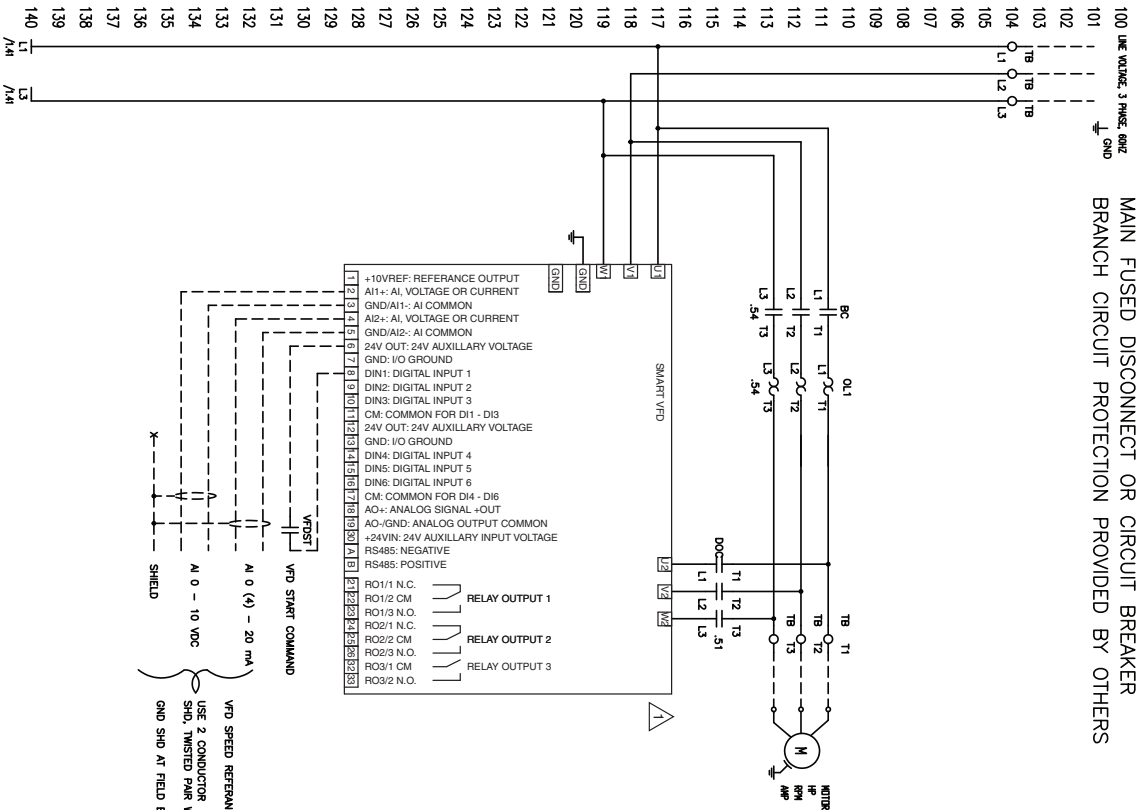

Fig. 1. 2 Contactor Wiring Diagram.

Table 1. SmartVFD Two Contactor Bypass.

Voltage	HP	AMPS	Frame	NEMA1	NEMA12	NEMA3R
				NEMA1 2-Contactor Bypass	NEMA12 2-Contactor Bypass	NEMA3R 2-Contactor Bypass
460	1.5 HP	3.4A	4	HVFDSB3C0015G120	HVFDSB3C0015G220	HVFDSB3C0015G320
	2 HP	4.8A	4	HVFDSB3C0020G120	HVFDSB3C0020G220	HVFDSB3C0020G320
	3 HP	5.6A	4	HVFDSB3C0030G120	HVFDSB3C0030G220	HVFDSB3C0030G320
	4 HP	8A	4	HVFDSB3C0040G120	HVFDSB3C0040G220	HVFDSB3C0040G320
	5 HP	9.6A	4	HVFDSB3C0050G120	HVFDSB3C0050G220	HVFDSB3C0050G320
	7.5 HP	12A	4	HVFDSB3C0075G120	HVFDSB3C0075G220	HVFDSB3C0075G320
	10 HP	16A	5	HVFDSB3C0100G120	HVFDSB3C0100G220	HVFDSB3C0100G320
	15 HP	23A	5	HVFDSB3C0150G120	HVFDSB3C0150G220	HVFDSB3C0150G320
	20 HP	31A	5	HVFDSB3C0200G120	HVFDSB3C0200G220	HVFDSB3C0200G320
	25 HP	38A	6	HVFDSB3C0250G120	HVFDSB3C0250G220	HVFDSB3C0250G320
	30 HP	46A	6	HVFDSB3C0300G120	HVFDSB3C0300G220	HVFDSB3C0300G320
	40 HP	61A	6	HVFDSB3C0400G120	HVFDSB3C0400G220	HVFDSB3C0400G320
	50 HP	72A	7	HVFDSB3C0500G120	HVFDSB3C0500G220	HVFDSB3C0500G320
	60 HP	87A	7	HVFDSB3C0600G120	HVFDSB3C0600G220	HVFDSB3C0600G320
	75 HP	105A	7	HVFDSB3C0750G120	HVFDSB3C0750G220	HVFDSB3C0750G320
	208	0.75 HP	3.7A	4	HVFDSB3A0007G120	HVFDSB3A0007G220
1 HP		4.8A	4	HVFDSB3A0010G120	HVFDSB3A0010G220	HVFDSB3A0010G320
1.5 HP		6.6A	4	HVFDSB3A0015G120	HVFDSB3A0015G220	HVFDSB3A0015G320
2 HP		8A	4	HVFDSB3A0020G120	HVFDSB3A0020G220	HVFDSB3A0020G320
3 HP		11A	4	HVFDSB3A0030G120	HVFDSB3A0030G220	HVFDSB3A0030G320
5 HP		18A	5	HVFDSB3A0050G120	HVFDSB3A0050G220	HVFDSB3A0050G320
7.5 HP		24A	5	HVFDSB3A0075G120	HVFDSB3A0075G220	HVFDSB3A0075G320
10 HP		31A	5	HVFDSB3A0100G120	HVFDSB3A0100G220	HVFDSB3A0100G320
15 HP		48A	6	HVFDSB3A0150G120	HVFDSB3A0150G220	HVFDSB3A0150G320
20 HP		62A	6	HVFDSB3A0200G120	HVFDSB3A0200G220	HVFDSB3A0200G320
25 HP		75A	6	HVFDSB3A0250G120	HVFDSB3A0250G220	HVFDSB3A0250G320
30 HP		88A	7	HVFDSB3A0300G120	HVFDSB3A0300G220	HVFDSB3A0300G320
40 HP		105A	7	HVFDSB3A0400G120	HVFDSB3A0400G220	HVFDSB3A0400G320
50 HP		140 A	8	HVFDSB3A0500G120	HVFDSB3A0500G220	HVFDSB3A0500G320
60 HP		170 A	8	HVFDSB3A0600G120	HVFDSB3A0600G220	HVFDSB3A0600G320
75 HP		205 A	8	HVFDSB3A0750G120	HVFDSB3A0750G220	HVFDSB3A0750G320

Table 1. SmartVFD Two Contactor Bypass. (Continued)

Voltage	HP	AMPS	Frame	NEMA1	NEMA12	NEMA3R
				NEMA1 2-Contactor Bypass	NEMA12 2-Contactor Bypass	NEMA3R 2-Contactor Bypass
230	0.75 HP	3.7A	4	HVFDSB3A0007G120	HVFDSB3A0007G220	HVFDSB3A0007G320
	1 HP	4.8A	4	HVFDSB3A0010G120	HVFDSB3A0010G220	HVFDSB3A0010G320
	1.5 HP	6.6A	4	HVFDSB3A0015G120	HVFDSB3A0015G220	HVFDSB3A0015G320
	2 HP	8A	4	HVFDSB3A0020G120	HVFDSB3A0020G220	HVFDSB3A0020G320
	3 HP	11A	4	HVFDSB3A0030G120	HVFDSB3A0030G220	HVFDSB3A0030G320
	5 HP	18A	5	HVFDSB3A0050G120	HVFDSB3A0050G220	HVFDSB3A0050G320
	7.5 HP	24A	5	HVFDSB3A0075G120	HVFDSB3A0075G220	HVFDSB3A0075G320
	10 HP	31A	5	HVFDSB3A0100G120	HVFDSB3A0100G220	HVFDSB3A0100G320
	15 HP	48A	6	HVFDSB3A0150G120	HVFDSB3A0150G220	HVFDSB3A0150G320
	20 HP	62A	6	HVFDSB3A0200G120	HVFDSB3A0200G220	HVFDSB3A0200G320
	25 HP	75A	6	HVFDSB3A0250G120	HVFDSB3A0250G220	HVFDSB3A0250G320
	30 HP	88A	7	HVFDSB3A0300G120	HVFDSB3A0300G220	HVFDSB3A0300G320
	40 HP	105A	7	HVFDSB3A0400G120	HVFDSB3A0400G220	HVFDSB3A0400G320
	50 HP	140 A	8	HVFDSB3A0500G120	HVFDSB3A0500G220	HVFDSB3A0500G320
	60 HP	170 A	8	HVFDSB3A0600G120	HVFDSB3A0600G220	HVFDSB3A0600G320
75 HP	205 A	8	HVFDSB3A0750G120	HVFDSB3A0750G220	HVFDSB3A0750G320	

SMARTVFD TWO CONTACTOR BYPASS ASSEMBLIES

Automation and Control Solutions

Honeywell International Inc.
1985 Douglas Drive North
Golden Valley, MN 55422
customer.honeywell.com

© U.S. Registered Trademark
© 2012 Honeywell International Inc.
62-0438—01 M.S. 10-12
Printed in United States

Honeywell