

## Y7230A CO<sub>2</sub> Alarm System FOR CO<sub>2</sub> GAS DETECTION



### QUICK INSTALLATION GUIDE

#### **!** CAUTION

- Make sure every entrance to the space containing the CO<sub>2</sub> source has a Strobe/Alarm AND a warning sign at eye level and unobstructed.
- Disconnect power supply before installation.
- Use the 12Vdc power supply supplied with the system or the replacement 50016095-001 power supply. Use of other power supplies will not permit proper operation of the system.
- Be sure to press the test button on the power supply to confirm proper wiring after installation. Follow the startup procedure in the operation section of this document.
- Make sure the CO<sub>2</sub> alarm power supply is mounted in location and orientation so the test push button is accessible by maintenance personnel.
- Do not spray cleaning fluids directly on sensor diaphragm.
- Replace sensor and power source immediately after a fire or flood.
- CO<sub>2</sub> Alarm System has been tested and approved with original components. Do not attempt to replace components with non-approved devices.
- To be installed by authorized beverage equipment technicians.
- Use only for determining CO<sub>2</sub> leaks in beverage dispensing equipment.

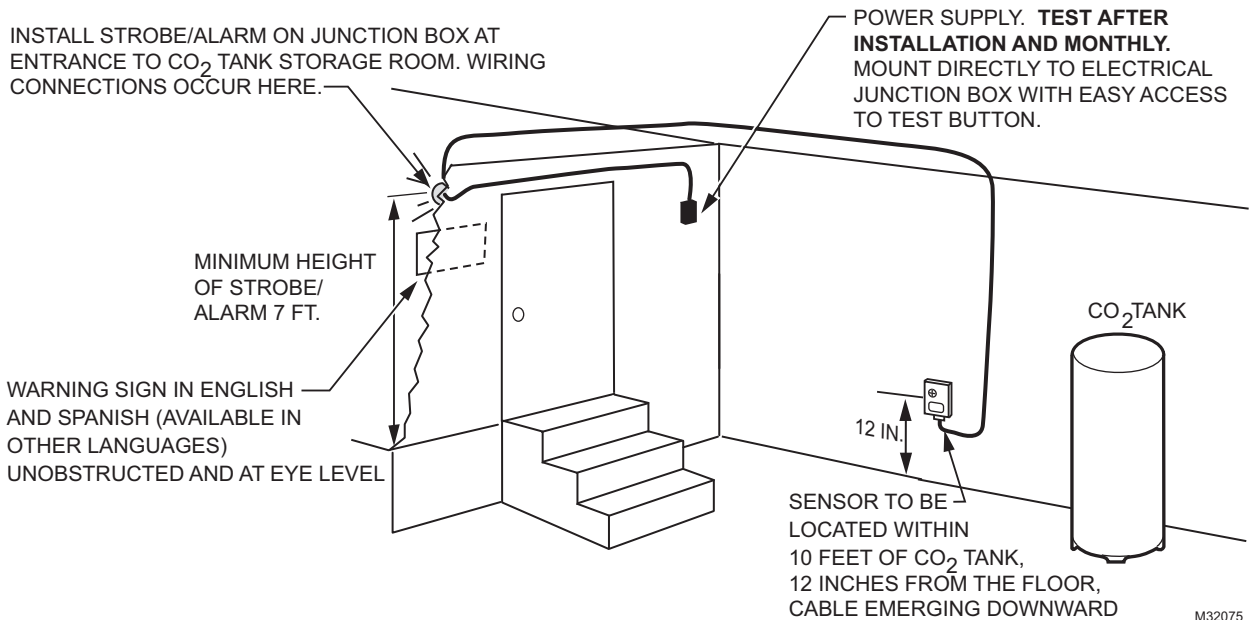

Fig. 1. Installation of system



## STEP 1. MOUNT STROBE/ALARM ON JUNCTION BOX, ON EITHER WALL OR CEILING

- Mount at each entrance to the space containing CO<sub>2</sub> source.
- If junction box is not already available mount a new junction box.
- Mount high on wall, minimum 7 ft, where it will not be obstructed by appliances or food racks.
- Mounting on ceiling also permitted.
- Set audio to 4 and Candela to 15/75.
- See Figure 2.

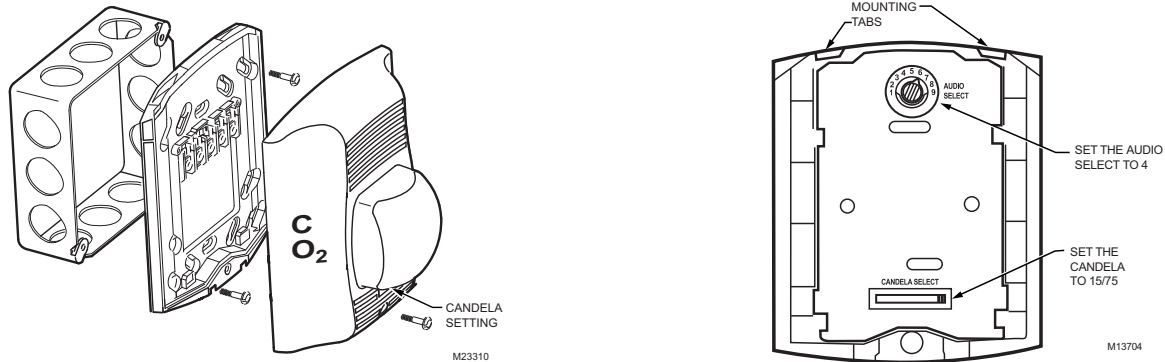

Fig. 2. Installation and settings of Strobe Alarm

## STEP 2. MOUNT POWER SUPPLY ON JUNCTION BOX WHERE CONSTANT POWER IS AVAILABLE

- Mount close to strobe/alarm if possible.
- Mount so that test button on the power supply can be easily accessed.
- If junction box is not already available, mount a new junction box.
- Attach and wire as shown in Figure 3.

## STEP 3. MOUNT CO<sub>2</sub> SENSOR ON WALL

- Mount in the same room within 10 feet of the CO<sub>2</sub> tank.
- Mount 12 inches above the finished floor (maximum of 24 inches above finished floor) with cable emerging downward.
- Run wire to strobe/alarm (most commonly above ceiling).

## STEP 4. RUN CO<sub>2</sub> SENSOR AND POWER SUPPLY WIRES BACK TO STROBE/ALARM

- All wire connections are made at the strobe alarm.
- Run wires above ceiling if possible. If not possible, secure cables to wall and run wires high near the ceiling.
- If cable length is too short, splice additional wire. Use 18 gauge for the power supply and 24 gauge for the sensor wiring. Wire the system using the appropriate diagrams Figures 4 - 7 and Tables 1 and 2.

## STEP 5. WIRING

See Figures 4 through 7 for wiring diagrams.

### IMPORTANT

All wiring shall comply with local electrical codes and ordinances.

Table 1. Wire Color Code for CO<sub>2</sub> Sensor.

Wire Color	Function	Rating
Red	12 Vdc ±10%	
Shield (Bare Silver)	GND	
White	0-5 Vdc for 0-30,000 ppm CO <sub>2</sub> to Honeywell Energy Management System	
Brown	12 Vdc output at 15,000 ppm CO <sub>2</sub>	1A at 24 Vdc
Black	12 VDC output at 30,000 ppm CO <sub>2</sub>	2A at 30 Vdc
Green Blue	Dry contact (potential free) (between Green and Blue wires) at 30,000 ppm CO <sub>2</sub>	2A at 30 Vdc

Table 2. Wire Color Code for Power Supply.

Wire Color	Function	Rating
<b>Power Supply - Primary</b>		
Black	120/240 Vac Common	
Red	120/240 Vac Hot	
<b>Power Supply - Secondary</b>		
Black	12 Vdc + Positive	
Black with gray stripe	- Negative	

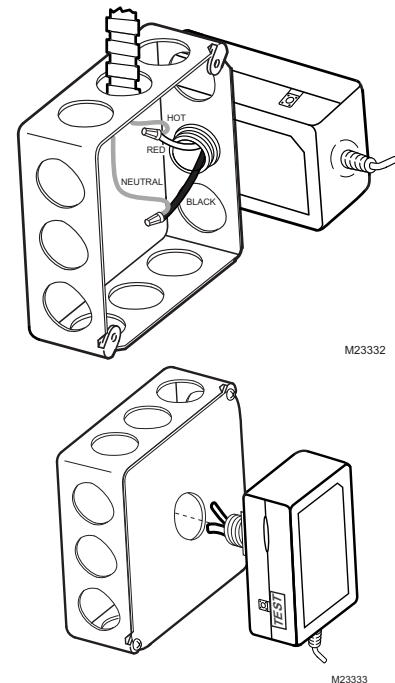
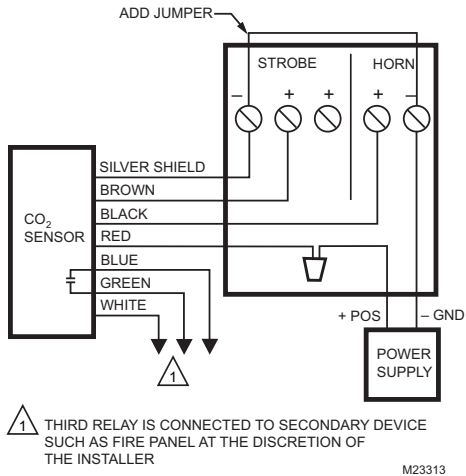
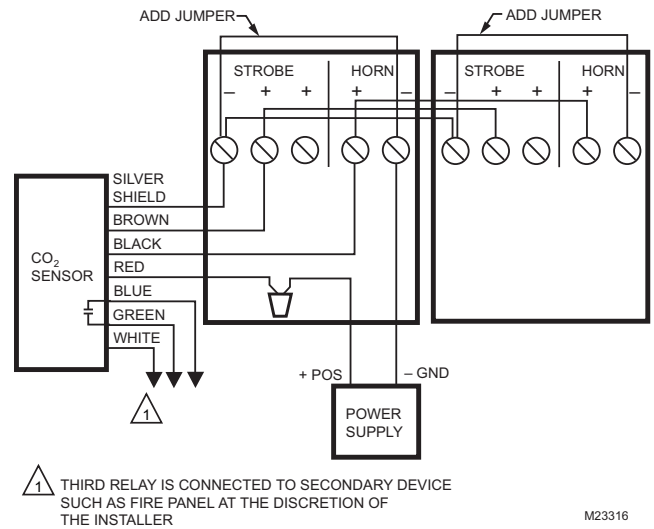

Fig. 3. Mount Power Supply on side or front of junction box with Test button easily accessible



**Fig. 4. Wiring for system with 1 strobe, 1 sensor and 1 power supply.**



**Fig. 6. Wiring for system with 2 strobes, 1 sensor and 1 power supply.**

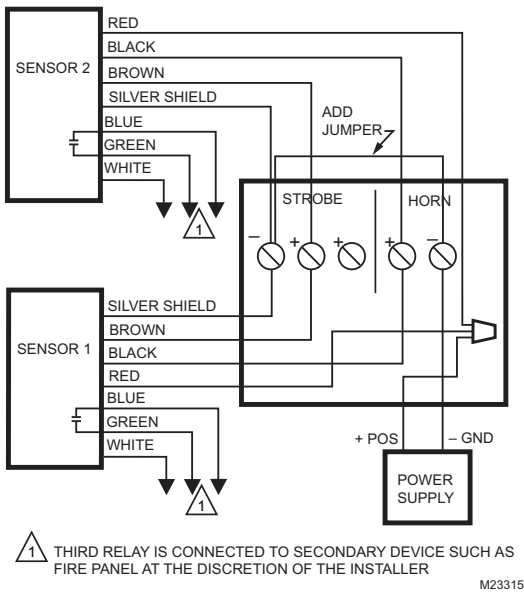

**Fig. 5. Wiring for system with 1 strobe, 2 sensors and 1 power supply.**

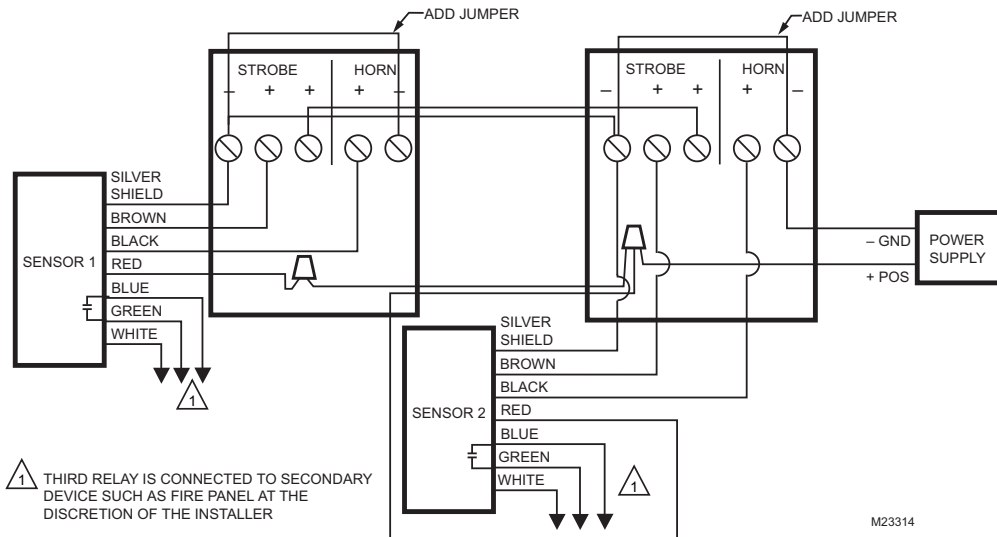

**Fig. 7. Wiring for system with 2 strobes, 2 sensors and 1 power supply.**

## OPERATION

### Start up

The start up sequence will verify the Strobe/Alarm and CO<sub>2</sub> sensor are wired correctly when power is applied to the system.

- Press test button or apply power.
- After approximately 15 seconds the horn will sound for about 2 seconds, the strobe will continue to flash for 5 - 10 seconds.
- Make sure green LED on the sensor is lit.
- Check wiring and power if this does not occur as described.

### Normal Operation

The purpose of the CO<sub>2</sub> alarm system is to activate a warning to building occupants when the CO<sub>2</sub> level in a space where tanks or bulk CO<sub>2</sub> is stored approaches a harmful level.

The CO<sub>2</sub> sensor will close a relay when 15,000 ppm CO<sub>2</sub> is sensed. The Strobe/Alarm will flash with a white light at >30 flashes per minute. Two additional relays will close when the CO<sub>2</sub> level reached 30,000 ppm. The second relay activates the audible alarm. The third relay is dedicated two-wire dry contact (blue and green wires). This third relay does not have to be connected in the system. This is at the discretion of the installer.

The CO<sub>2</sub> sensor will also output a linear 0-5 Vdc signal where 0 Vdc is 0 ppm CO<sub>2</sub> and 5 Vdc is 30,000 ppm CO<sub>2</sub>.

When CO<sub>2</sub> levels decrease or power is removed, the relays will open and the audible and flashing alarms will stop.

The CO<sub>2</sub> sensor has a solid on green LED when power is supplied to the sensor.

## Field Adjustments

The system is not field adjustable.

## CHECKOUT AND TROUBLE SHOOTING

### IMPORTANT

*Test system monthly by depressing the push button on the power supply to make sure system has not been tampered with and is operating normally.*

### Testing System (once per month)

1. Press Test button on Power Supply.
2. After approximately 15 seconds, horn will sound for 2 seconds, strobe flashes for additional 5-10 seconds.
3. System is working unless this does not occur as described. Check wiring and power if this does not occur as described.

The CO<sub>2</sub> sensor has an Automatic Background Calibration. If the background calibration drifts from the factory calibration by 3,000 ppm, the strobe light will flash 10 seconds every minute. If this occurs it could indicate a slow leak in CO<sub>2</sub> equipment. Ventilate the space. Replace the sensor and check for slow leaks in the CO<sub>2</sub> equipment. Replace any leaking equipment.

### IMPORTANT

*Strobe will flash for 10 seconds every minute when out of calibration and sensor needs to be replaced.*

If the flashing repeats after a period of a few months with a replacement sensor, there is possibly a slow leak in the CO<sub>2</sub> equipment. Investigate the leak and replace the leaking equipment.

Use of a power supply other than that supplied with the system or the replacement 50016095-001 power supply will not permit proper operation of the system.

## APPROVED ACCESSORIES AND REPLACEMENT PARTS:

50016094-001: Replacement CO<sub>2</sub> sensor with a range of 0-30,000 ppm

50016095-001: Replacement 12 Vdc power supply with a button override

P4W-ECC: Replacement CO<sub>2</sub> alarm/strobe

62-0225ES: English/Spanish warning sign\*

62-0225EI: English/Italian warning sign\*

62-0225EG: English/German warning sign\*

62-0225EP: English/Portuguese warning sign\*

62-0225ED: English/Dutch warning sign\*

62-0225EJ: English/Japanese warning sign\*

62-0225EC: English/Chinese warning sign\*

62-0225EF: English/French Canadian warning sign\*\*

63-2641; CO<sub>2</sub> Alarm System Quick Product Data

63-4369; CO<sub>2</sub> Alarm System Monthly Test Checklist

\*Packet of 25 signs

\*\*Packet of 25 signs and 25 Product Data sheets in French (63-2641F)

### Automation and Control Solutions

Honeywell International Inc.

1985 Douglas Drive North

Golden Valley, MN 55422

Honeywell Limited-Honeywell Limitée

35 Dynamic Drive

Toronto, Ontario M1V 4Z9

customer.honeywell.com

# Honeywell