

## C7100A,B,C,D Averaging Temperature Sensors

### INSTALLATION INSTRUCTIONS

#### APPLICATION

The C7100A,B,C,D Averaging Temperature Sensors provide the input required by the W7080, W7100, Excel 500, and T775 Control Systems to sense temperature in discharge, hot deck, cold deck or return air.

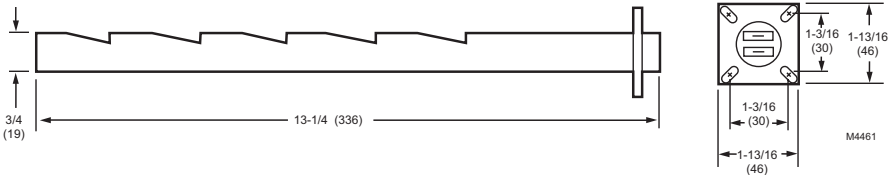

Fig. 1. Approximate dimensions of C7100 Averaging Temperature Sensor in in. (mm).

#### INSTALLATION

##### When Installing this Product...

1. Read these instructions carefully. Failure to follow them could damage the product or cause a hazardous condition.
2. Check the ratings given in the instructions and on the product to make sure the product is suitable for your application.
3. Installer must be a trained, experienced service technician.
4. After installation is complete, check out product operation as provided in these instructions.

The sensor assembly (see Fig. 1) consists of an aluminum sensor probe (element housed internally) with attached flange that can be mounted on a flat duct or plenum surface, or in a 2 by 4 in. (51 by 102 mm) junction box using four No. 8 screws. Connections to the sensor are made through two recessed 1/4 in. (6 mm) quick-connect terminals.

##### Location

The sensor should be located in the air duct or plenum where it will sample an average air temperature. Avoid locations where air stratification can cause sensor errors.

#### Mounting

##### Flat Duct or Plenum Surface Mounting (See Fig. 2)

1. Cut a 7/8 in. (22 mm) hole in the duct or plenum surface at the desired location.
2. Insert sensor probe into the duct or plenum with inlet holes facing the air stream.
3. If necessary, use the flange as a template to mark and drill four holes for No. 8 mounting screws.
4. Fasten the sensor to the duct or plenum surface with four No. 8 sheet metal screws (not provided).

##### Junction Box Mounting (See Fig. 3)

1. Cut a 7/8 in. (22 mm) hole in the duct or plenum surface at the desired location.
2. Remove the center rear knockout from the junction box and insert the sensing probe through the knockout with the flange flat against the junction box.
3. Using the flange as a template, mark and drill four holes in the junction box and the duct or plenum surface for No. 8 mounting screws.
4. Insert sensor probe through both the junction box knockout and the 7/8 in. (22 mm) hole drilled in the duct or plenum and fasten the junction box and sensor to the duct or plenum surface.

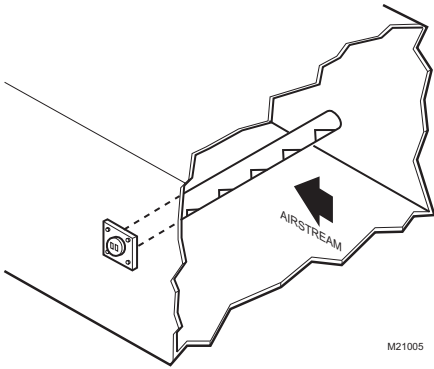

Fig. 2. C7100 duct or plenum mounting.

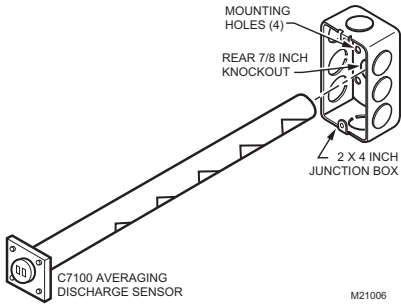

Fig. 3. C7100 junction box mounting.

**IMPORTANT**

All wiring must agree with applicable codes, ordinances and regulations.

Connect low voltage wiring from the sensor to the appropriate system component terminals using 1/4 in. (6 mm) female quick-connectors at both ends. See Fig. 4 and 5.

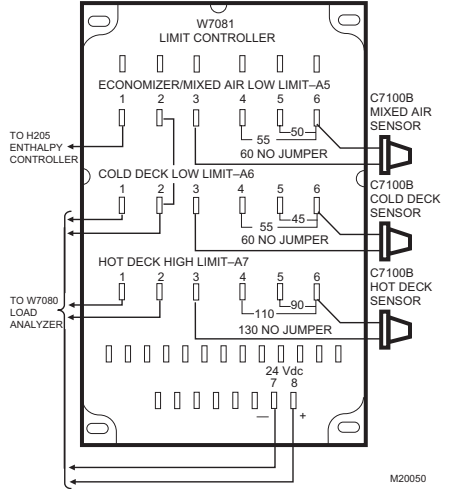

Fig. 4. Connecting C7100B for economizer, mixed air and deck temperature sensing.

**WIRING**

**CAUTION**

**Electrical Shock or Equipment Damage Hazard.**  
Can shock individuals or short equipment circuitry.  
Disconnect power supply before installation.

**CAUTION**

**Erratic System Operation Hazard.**  
Failure to follow proper wiring practices can introduce disruptive electrical interference (noise).  
Keep wiring at least one foot away from large inductive loads such as motors, line starters, lighting ballasts, and large power distribution panels.  
Shielded cable is required in installations where these guidelines cannot be met.  
Ground shield only to grounded controller case.

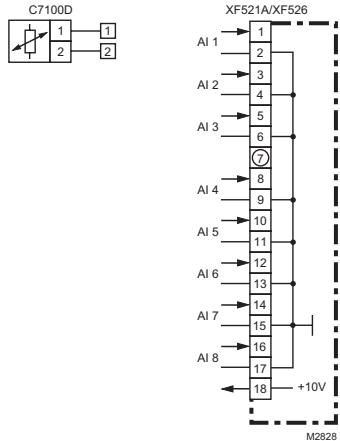

Fig. 5. Connecting C7100D to Excel 500 Control System.

## OPERATION AND CHECKOUT

### Operation

The C7100A,C,D Averaging Temperature Sensors consist of a platinum alloy resistance element, mounted in a tubular probe. The C7100B Averaging Temperature Sensor consists of a thermistor sensing element mounted in a tubular probe. They are applied at various locations throughout the systems. The probe has five shear-formed inlet openings that face into the air stream. The air entering these inlet openings is directed by the shear forms toward the sensor located within the probe. The probe mixes the various air samples entering the inlets to present an average temperature air sample to the sensing element. The sensing element resistance is therefore dependent on the average temperature of the sampled air.

This method of temperature averaging provides more accurate temperature control by reducing or eliminating the effects of duct and/or plenum air stratification.

Fig. 6 shows how the sensor resistance varies with temperature for a sensor having a positive temperature coefficient (PTC) of 4.8 ohms per degree F (8.6 ohms per degree C).

Fig. 7 shows how thermistor resistance varies with temperature for a sensor having a negative temperature coefficient (NTC).

Fig. 8 shows how sensor resistance varies with temperature for a sensor having a positive temperature coefficient (PTC) of 2.1 ohms per degree F (3.85 ohms per degree C).

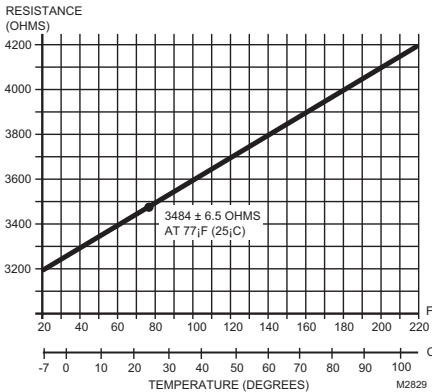

Fig. 6. C7100A,C Sensor resistance vs. temperature.

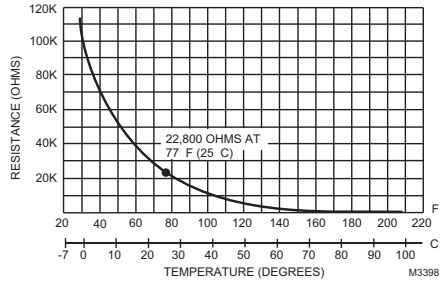

Fig. 7. C7100B Sensor resistance vs. temperature.

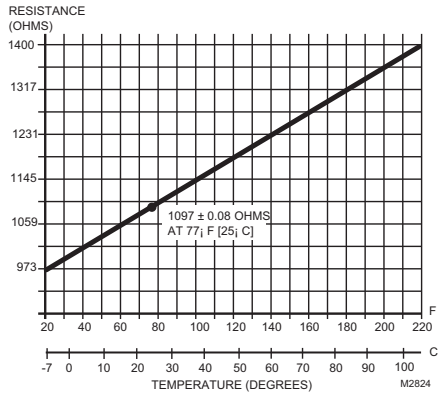

Fig. 8. C7100D Sensor resistance vs. temperature.

### Checkout

Allow the C7100 Averaging Temperature Sensor to soak in the air moving through the duct or plenum for a minimum of ten minutes before taking a resistance measurement.

1. Disconnect the sensor leadwires from the associated system components.
2. Connect an ohmmeter across the leadwires.
3. Assure nominal resistance measurements are in accordance with the resistance/temperature curves (see Fig. 6 through 8).
4. Reconnect sensor leadwires to associated system components.
5. Check operation of the complete control system.

**Honeywell**

---

**Automation and Control Solutions**

Honeywell International Inc.  
1985 Douglas Drive North  
Golden Valley, MN 55422

Honeywell Limited-Honeywell Limitée  
35 Dynamic Drive  
Scarborough, Ontario  
M1V 4Z9

