



## Instrumentation Products

Modular Mounting System



# Product Overview

## Product Overview

AS-Schneider's Modular Mounting System (MMS) provides substantial advantages by the simplest and most effective means to install Transmitters and Gauges. The MMS series are designed to be compatible with the Shell® MESC specifications for Process Instrumentation.



## MMS Main Components

- Instrument Monoflange
- Manifolds

## Features

The MMS components are designed to be used with Transmitters or Gauges for general Pressure and Differential Pressure Measurements.

All components benefit from a Compact Design, reduced installation costs and less potential leak points.

- Inlet and Vent connections are supplied G 1/4 parallel threaded acc. to DIN 3852 part 2
- Suitable for Liquid and Gas Service
- Connections can be assembled with Tube Fittings
- Fully self-draining
- Wide choice of Manifold Configurations to suit your application

## Options

- Special Design to be used with Rosemount® Coplanar™ style Pressure / Differential Pressure Transmitters
- NACE (Sour Gas Service)
- Wide range of Exotic Materials on request
- Special Connections on request
- Choice of Accessories:
  - Mounting Brackets
  - Steam Tracing Blocks
  - Electrical Heaters
  - Single and Double Vent Purge Blocks
  - Seal Pots
  - Filling Connectors
  - Blind Flanges
  - Heaters
  - Protective Shades and Enclosures
  - Anti-Tamper Key

## Standard Features

- Seat metal/metal
- Packing PTFE or graphite
- Non-rotating valve tip
- Colour coded valve head units
- Equalize and Vent Valves are equipped with an Anti-Tamper facility

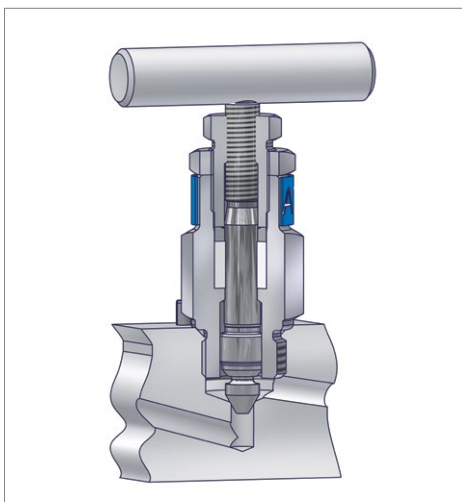

## Optional Features

- Low Emission Valve Designs:
  - Type Tested Design according to ISO 15848-1 and Production Test according to ISO 15848-2
  - According to TA-Luft

## Pressure-Temperature Rating Needle Valve

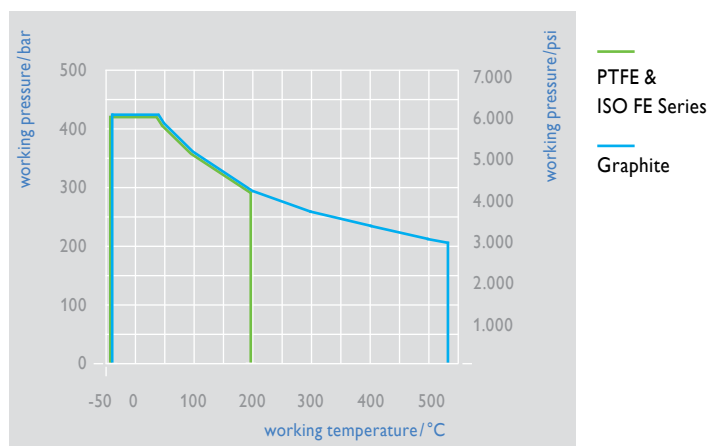

## ISO FE Series

### For maximum leak tightness demands!

Rising energy consumption, dwindling natural resources and the increasingly stringent legal requirements force the industry to rethink and employ emission-reducing equipment. This also applies to the instrumentation valves and manifolds range.

As response to the current and especially the future market demands, AS-Schneider, in the framework of the new ISO FE Series, has developed an innovative valve technology meeting the highest tightness class "A" of ISO 15848-1. With a maximum permissible leak rate of  $1.3 \cdot 10^{-7}$  mbar · l/s (for a stem diameter of 7.5 mm), this class even exceeds the requirements of TA-Luft.

Three different sealing systems are available for the AS-Schneider ISO FE Series.

Pressure rating PN 420 / Class 2,500 applies to all types:

AS-Schneider TYPE	SEALING SYSTEM	PERFORMANCE DATA
ISO FE Series Type 1	FPM O-ring + graphite packing	Class A: 500 cycles / -29 °C to 200 °C Class A: 1,500 cycles / -29 °C to 40 °C Class B: 1,500 cycles / -29 °C to 200 °C
ISO FE Series Type 2	FPM O-ring + graphite packing	Class A: 1,500 cycles / -29 °C to 200 °C
ISO FE Series Type 3	PTFE / carbon-filled PTFE	Class A: 1,500 cycles / -29 °C to 40 °C Class B: 1,500 cycles / -29 °C to 200 °C

# Instrument Monoflange SM

## Product Description

The SM Instrument Monoflange is an Isolate / Vent Gauge Block for Pressure Gauges or Transmitters using screwed connections. The gauge connection is equipped with a Swivel Gauge Adaptor which enables the easy positioning of the gauge in any direction through 360°. It is suitable for Horizontal or Vertical flange mounting and can be assembled directly to the primary isolation valve.

## Rating

Maximum working pressure:  
 100 bar @ 38°C (LPR 150-600 lbs)  
 413 bar @ 38°C (HPR 900-2500 lbs)

Maximum working temperature: 200°C

## Connections

Instrument:  
 Swivel Gauge Adaptor with 1/2 NPT and G 1/2 female threads available. It can be supplied as an Integral Syphon type.

Process:  
 1/2" flange acc. to ASME B16.5  
 Available as LPR (150-600 lbs) and HPR (900-2500 lbs) RF smooth finish

Vent:  
 G 1/4 Female  
 Can be equipped with Compression Fittings

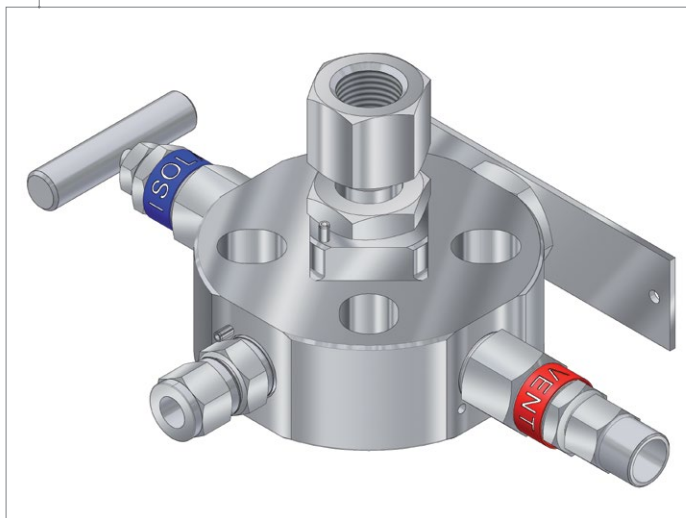
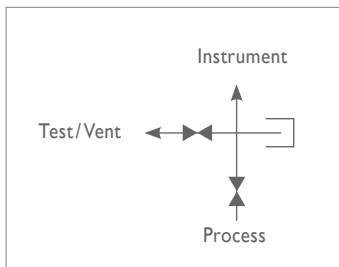

Instrument Monoflange Type G

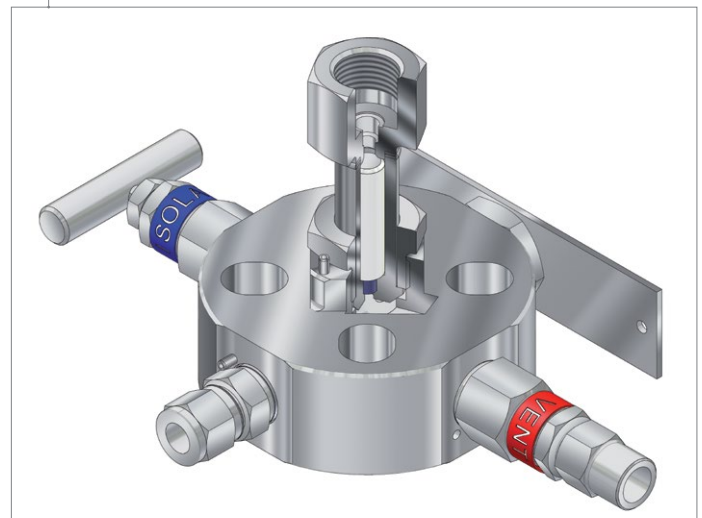

Instrument Monoflange Type S

## Standard Monoflanges

MESC CODE	DESCRIPTION	VENT	AS-Schneider P/N
MESC 60.98.55.200.1	Instrument Monoflange 1/2" 150 – 600 Type G	G 1/4-F	SMA-GLN-SG00
MESC 60.98.55.210.1	Instrument Monoflange 1/2" 900 – 2500 Type G	G 1/4-F	SMA-GHN-SG00
MESC 60.98.55.220.1	Instrument Monoflange 1/2" 150 – 600 Type G	G 1/4-F	SMA-GLG-SG00
MESC 60.98.55.230.1	Instrument Monoflange 1/2" 900 – 2500 Type G	G 1/4-F	SMA-GHG-SG00
MESC 60.98.55.300.1	Instrument Monoflange 1/2" 150 – 600 Type S	G 1/4-F	SMA-SLN-SG00
MESC 60.98.55.310.1	Instrument Monoflange 1/2" 900 – 2500 Type S	G 1/4-F	SMA-SHN-SG00
MESC 60.98.55.320.1	Instrument Monoflange 1/2" 150 – 600 Type S	G 1/4-F	SMA-SLG-SG00
MESC 60.98.55.330.1	Instrument Monoflange 1/2" 900 – 2500 Type S	G 1/4-F	SMA-SHG-SG00

## Ordering Information | Referring to Instrument Monoflange SM

	1 2	3	4	5	6	7	8	9	10	11	12	13	14
	SM	A	-	G	L	G	-	S	G	0	0		
<b>INSTRUMENT MONOFLANGE</b>													
<b>PACKING</b>													
A	PTFE												
B	Graphite												
L	ISO FE Series Type 1												
M	ISO FE Series Type 2												
N	ISO FE Series Type 3												
<b>TYPE</b>													
G	Swivel Gauge Adaptor												
S	Swivel Gauge Adaptor with Integral Syphon												
<b>PRESSURE RATING</b>													
L	LPR (150, 300, 600 lbs)												
H	HPR (900, 1500, 2500 lbs)												
<b>THREAD</b>													
G	G1/2 Female												
N	1/2 NPT Female												
<b>MATERIAL</b>													
S	316 SST												
H	Alloy C-276												
M	Alloy 400												
<b>VENT CONNECTION</b>													
G	G1/4 Female												
B	1/4 NPT Female												
<b>COMPRESSION FITTING</b>													
0	Without Compression Fitting												
A	A-Lok®												
R	Rotarex												
S	Swagelok®												
<b>SIZE OF COMPRESSION FITTING</b>													
0	Without Compression Fitting												
3	10 mm												
4	12 mm												
8	3/8"												
9	1/2"												
<b>OPTIONS (if applicable)</b>													
B	Oxygen Service												
N	NACE/Sour Gas Service (valve stem and valve tip in Alloy 400)*												
T	Anti-Tamper Key												
<b>ADDITIONAL OPTION (if applicable)</b>													
0	No additional Option												

\* 316 SST type includes NACE option with valve stem and valve tip in 316 SST - Does not correspond to Shell MESG Spec.



# Manifold SB

## Product Description

The SB Manifold can be assembled directly to a standard Mounting Plate, eliminating the need for extra Mounting Accessories and reducing pipe work on site. The SB Manifolds can also be supplied with a wide Choice of Accessories.

## Rating

Maximum working pressure: 413 bar @ 38°C

Maximum working temperature:

- 200°C for PTFE packing and ISO FE Series option
- 550°C for graphite packing

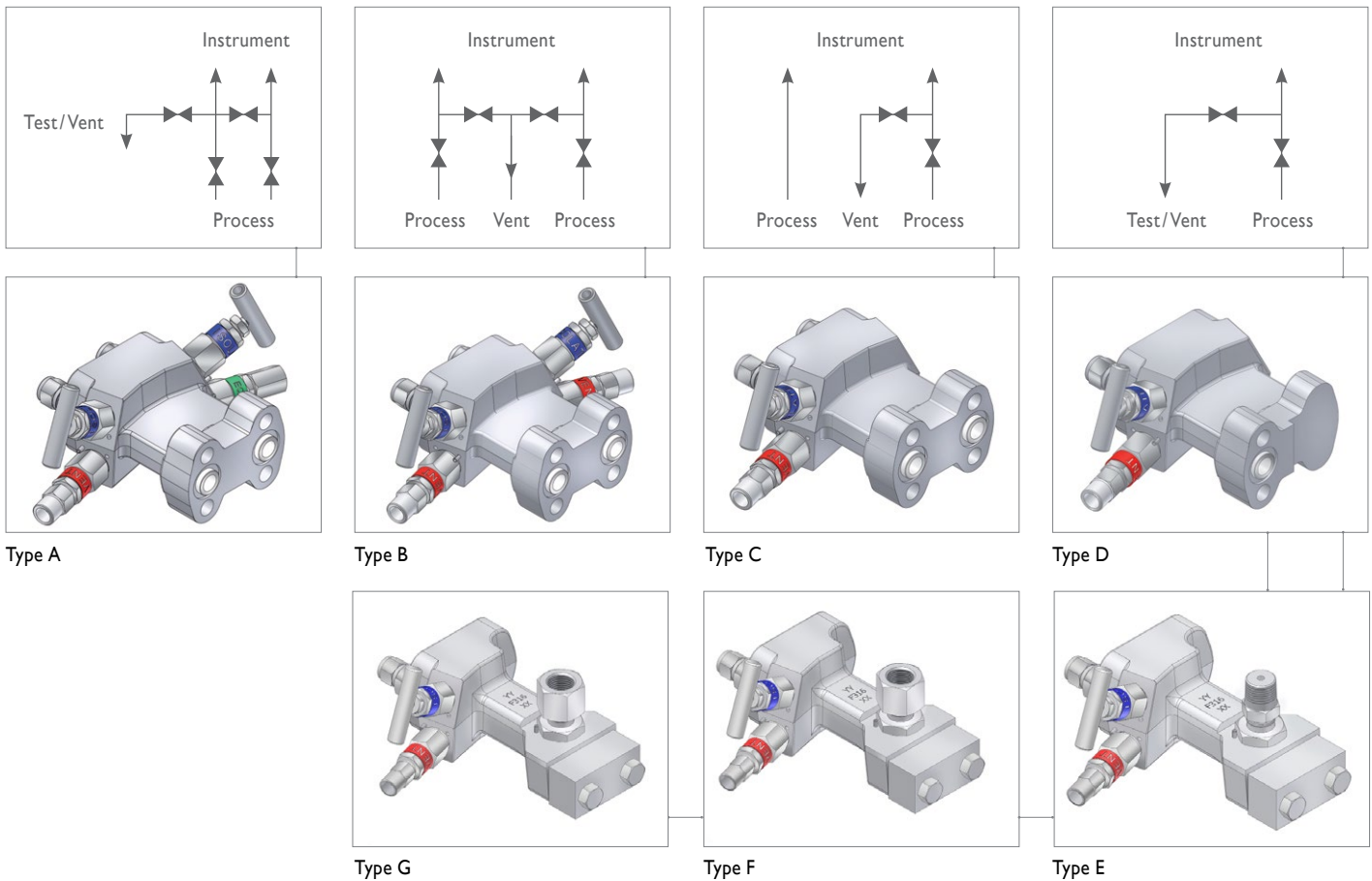

## Different Types for Different Applications

Type	MESC CODE	DESCRIPTION	VENT	AS-Schneider P/N
A	MESC 60.98.56.205.1	<b>4 Valve Manifold</b>	10 mm*	SBA-AA0-SG*3
	MESC 60.98.56.207.1	For general applications	3/8"*	SBA-AA0-SG*8
B	MESC 60.98.56.215.1	<b>4 Valve Manifold</b>	10 mm*	SBA-BA0-SG*3
	MESC 60.98.56.217.1	For applications where contamination of process steam is not permitted	3/8"*	SBA-BA0-SG*8
C	MESC 60.98.56.225.1	<b>2 Valve Manifold</b>	10 mm*	SBA-CA0-SG*3
	MESC 60.98.56.227.1	For Pressure applications and level measurements on atmospheric tanks	3/8"*	SBA-CA0-SG*8
D	MESC 60.98.56.235.1	<b>2 Valve Manifold</b>	10 mm*	SBA-DA0-SG*3
	MESC 60.98.56.237.1	For pressure transmitters of the differential body design	3/8"*	SBA-DA0-SG*8
E	MESC 60.98.56.305.1	<b>2 Valve Manifold</b>	10 mm*	SBA-EA0-SG*3
	MESC 60.98.56.325.1	For pressure transmitters using screwed connection	3/8"*	SBA-EA0-SG*8
F	MESC 60.98.56.315.1	<b>2 Valve Manifold</b>	10 mm*	SBA-FA0-SG*3
	MESC 60.98.56.335.1	For pressure transmitters using screwed connection	3/8"*	SBA-FA0-SG*8
G	MESC 60.98.56.317.1	<b>2 Valve Manifold</b>	10 mm*	SBA-GA0-SG*3
	MESC 60.98.56.337.1	For pressure transmitters using screwed connection	3/8"*	SBA-GA0-SG*8

\* Compression Fitting - make, type, size and composition as specified in the requisition/indent.

## Ordering Information | Manifold SB

	1 2	3	4	5	6	7	8	9	10	11	12	13	14
	S B	A	-	A	A	0	-	S	G	R	3		
<b>MANIFOLD</b>													
<b>PACKING</b>													
A	PTFE												
B	Graphite (only if field 6 = C)												
L	ISO FE Series Type 1												
M	ISO FE Series Type 2												
N	ISO FE Series Type 3												
<b>TYPE</b>													
A	Double Isolate / Equalize / Vent (General)												
B	Double Isolate / Vent (Anti-Contamination)												
C	Single Isolate / Vent (DP)												
D	Single Isolate / Vent (Pressure, DP design)												
E	Single Isolate / Vent (1/2 NPT Male)												
F	Single Isolate / Vent (1/2 NPT Female)												
G	Single Isolate / Vent (G 1/2 Female)												
<b>TRANSMITTER CONNECTION</b>													
A	DIN 19213 part 2 rev. 1980 or threaded												
B	Integral for Rosemount 3051® (Type A, B, C and D only)												
C	DIN EN/IEC 61518 - Type A												
<b>MATERIAL</b>													
S	316 SST												
H	Alloy C-276												
M	Alloy 400												
<b>PROCESS / VENT CONNECTION</b>													
G	G 1/4 Female / G 1/4 Female												
B	1/2 NPT Female / 1/4 NPT Female												
C	1/4 NPT Female / 1/4 NPT Female												
<b>COMPRESSION FITTING</b>													
0	Without Compression Fitting												
A	A-Lok®												
R	Rotarex												
S	Swagelok®												
<b>SIZE OF COMPRESSION FITTING</b>													
0	Without Compression Fitting												
3	10 mm												
4	12 mm												
8	3/8"												
9	1/2"												
<b>OPTIONS (if applicable)</b>													
B	Oxygen Service												
N	NACE/Sour Gas Service (valve stem and valve tip in Alloy 400)*												
T	Anti-Tamper Key												
<b>ADDITIONAL OPTION (if applicable)</b>													
0	No additional Option												

Type A, B, C, D is supplied with SST hexagon cap screws 7/16-20 UNF x 1 1/2" and PTFE or graphite sealing washers.

\* 316 SST type includes NACE option with valve stem and valve tip in 316 SST - Does not correspond to Shell MESC Spec.

# Mounting Bracket SAM

## Product Description

The SAM Mounting Brackets are designed to ensure a Simple and Quick Installation of Manifolds with other Accessories including the Nameplate.

There are four different types of Mounting Brackets available. The brackets are made of 316 SST and are designed to be assembled to a 2" Pipestand.

Type A is used, if a Protective Shade is required.

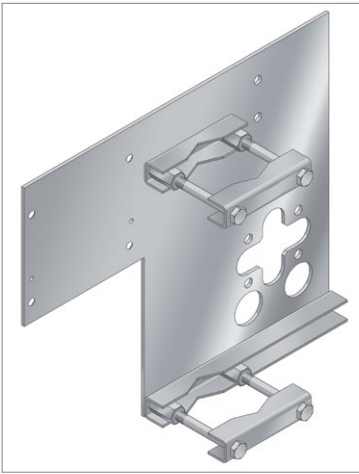

SAM-A1

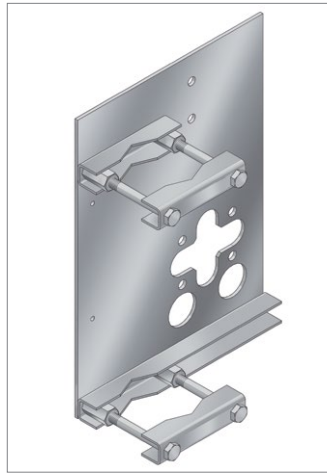

SAM-A2

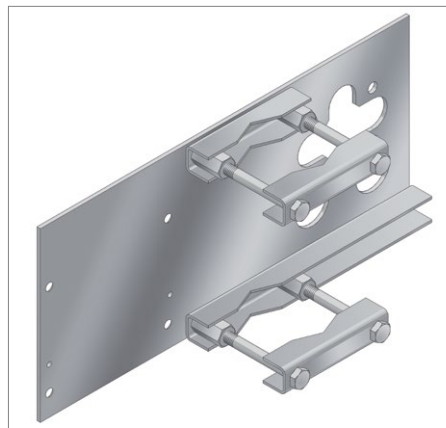

SAM-B1

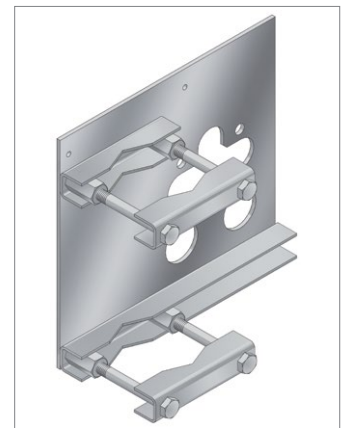

SAM-B2

## Ordering Code

MESC CODE	STANDARD DRAWING	DESCRIPTION	AS-Schneider P/N
MESC 60.98.91.105.1	37.813	Mounting Bracket A1	SAM-A1
MESC 60.98.91.110.1	37.815	Mounting Bracket A2	SAM-A2
MESC 60.98.91.118.1	37.814	Mounting Bracket B1	SAM-B1
MESC 60.98.91.120.1	37.816	Mounting Bracket B2	SAM-B2
-	37.601	Stainless Steel Tag Plate	SAC-S00



## Product Description

The SVA Purge Blocks have two main applications:

- Purge protection of the instrument using a purge medium to keep the process away from the instrument by maintaining a higher pressure than the process medium.
- To provide a sensing medium for differential pressure instruments on level indication services.

There are two Vent Purge Blocks available, the Double Vent Purge Block SVA-D for differential pressure application and the Single Vent Purge Block SVA-S for static pressure applications.

## Rating

Maximum working pressure: 413 bar @ 38°C

Maximum working temperature:

- 200°C for PTFE packing and ISO FE Series option
- 550°C for graphite packing

## Connections

Outlets:

Are equipped with Soft-Seated Check Valves

Inlet:

Is provided with an Integral Filter

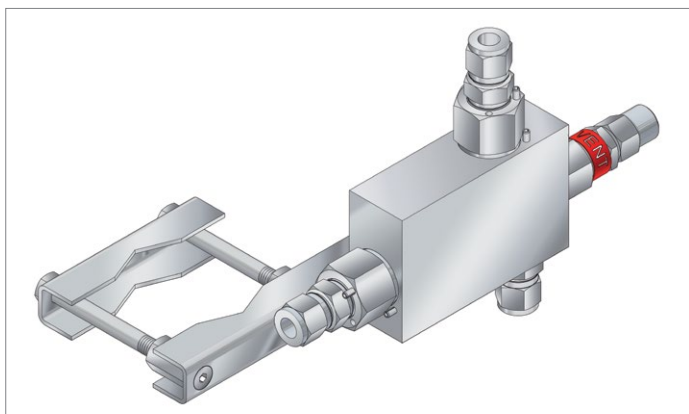

SVA-S00-SGS3  
Single

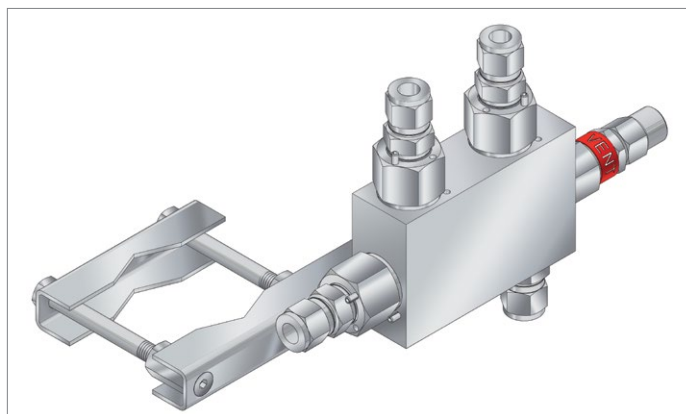
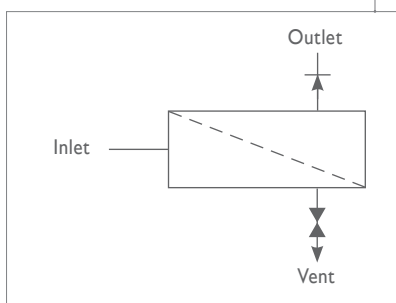

SVA-D00-SGS3  
Double

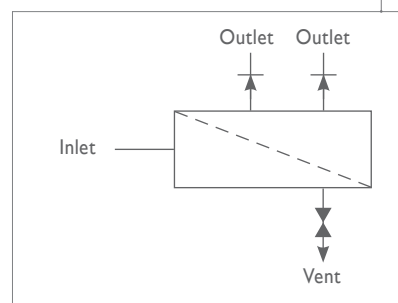

## Ordering Code

MESC CODE	DESCRIPTION	VENT	AS-Schneider P/N	Ordering Code, Field 3 & 9 – 14
MESC 60.98.70.210.1	Single Vent Purge Block / Type S	10 mm*	SVA-S00-SG*3	See page 7
MESC 60.98.70.310.1		3/8**	SVA-S00-SG*8	
MESC 60.98.70.220.1	Double Vent Purge Block / Type D	10 mm*	SVA-D00-SG*3	
MESC 60.98.70.320.1		3/8**	SVA-D00-SG*8	

\* Compression Fitting - make, type, size and composition as specified in the requisition/indent.

# Seal Pot SSB

## Product Description

The Seal Pot SSB is used for systems requiring an open seal such as high temperature, toxic or corrosive service. The Seal Pot is used with an Immiscible Seal Fluid. The difference in density to the process media will provide a barrier in front of the Manifold and Instrument.

## Placement

Seal Pot is located below the Orifice plate:  
A Seal Fluid with higher specific gravity than the Process Medium is to be used.

Seal Pot is located above the Orifice plate:  
A Seal Fluid with lower specific gravity is to be used.

## Rating

Maximum working pressure: 413 bar @ 38°C  
Maximum working temperature: 450°C

## Volume

Approx. 50 cm<sup>3</sup>

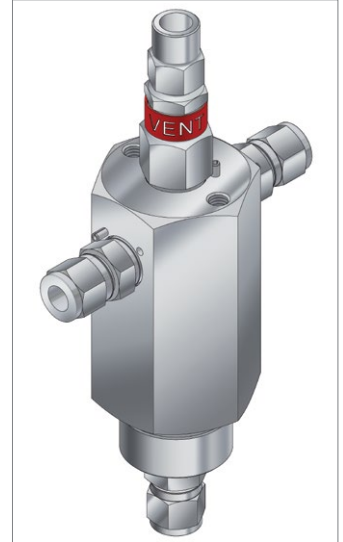

## Ordering Code

MESC CODE	DESCRIPTION	VENT	AS-Schneider P/N
MESC 60.98.70.510.1	Seal Pot	10mm*	SSB-000-SG*3
MESC 60.98.70.600.1		1/2"*	SSB-000-SG*9
MESC 60.98.70.610.1		3/8"*	SSB-000-SG*8

\* Compression Fitting - make, type, size and composition as specified in the requisition/indent.

## Ordering Information | Seal Pot SSB & Steam Heating SAS

1	2	3	4	5	6	7	8	9	10	11	12	13	14
S	S	B	-	0	0	0	-	S	G	R	3		
S	A	S											

MATERIAL	
S	316 SST
H	Alloy C-276
M	Alloy 400
PROCESS / VENT CONNECTION	
G	G 1/4 Female / G 1/4 Female
C	1/4 NPT Female / 1/4 NPT Female
COMPRESSION FITTING	
0	Without Compression Fitting
A	A-Lok®
R	Rotarex
S	Swagelok®
SIZE OF COMPRESSION FITTING	
0	Without Compression Fitting
3	10 mm
4	12 mm
8	3/8"
9	1/2"
OPTIONS (if applicable)	
B	Oxygen Service
N	NACE/Sour Gas Service (valve stem and valve tip in Alloy 400)*
T	Anti Tamper Key
ADDITIONAL OPTION (if applicable)	
0	No additional Option

\* 316 SST type includes NACE option with valve stem and valve tip in 316 SST - Does not correspond to Shell MESC Spec.

## Product Description

The SAS Steam Tracing Block & SAE Electrical Heating are used to provide Frost Protection and to maintain Process Temperatures given that the heaters are mounted directly to the Manifold which ensures efficient Heat Transfer to the Manifold and Transmitter Body.

### Steam Heating SAS

Steam Heating is provided through a separate stainless steel Steam Block which is mounted directly to the Manifold with one stainless steel M8 Mounting Bolt.

The Connection to the Steam Line is provided by two G 1/4 Female Ports equipped with Tube Fittings.

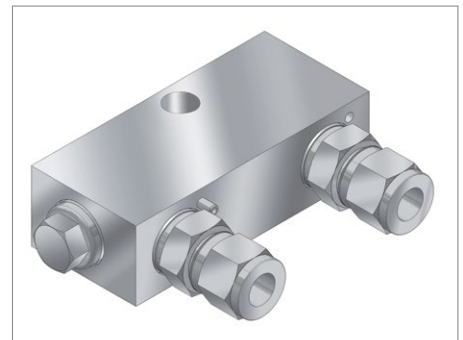

### Electrical Heating SAE

Conduction Heating with self-limiting output characteristic, supplied with cable length of 1m. Is directly mounted to the Manifold with one stainless steel M8 Mounting Bolt.

Material: Aluminium (sea water resistant)  
 Size: 90 x 40 x 30mm  
 Voltage: 110V – 265V  
 Rating: 50W  
 Type of Protection: IP68, NEMA 4X  
 Explosion Proof: II 2 GD EEx d IIC T4  
 Certificate No. (PTB): 02 ATEX 1116 X



## Ordering Code

MESC CODE	DESCRIPTION	VENT	AS-Schneider P/N	Ordering Code, Field 4 – 14
MESC 60.98.70.010.1	Steam Tracing Block	10 mm*	SAS-000-SG*3	See page 10
MESC 60.98.70.110.1		3/8**	SAS-000-SG*8	
MESC 60.98.70.050.1	Electrical Heater		SAE	

\* Compression Fitting - make, type, size and composition as specified in the requisition/indent.

# Filling Connector SAF

## Product Description

The SAF Filling Connector is used if purge protection is required but no purge block is installed. The Filling Connector allows the system to be filled with Purge Medium through the instrument cavities. The Filling Connector has an integral Check Valve and is available with different connections.

## Rating

Maximum working pressure: 413 bar @ 38°C

Maximum working temperature: 200°C

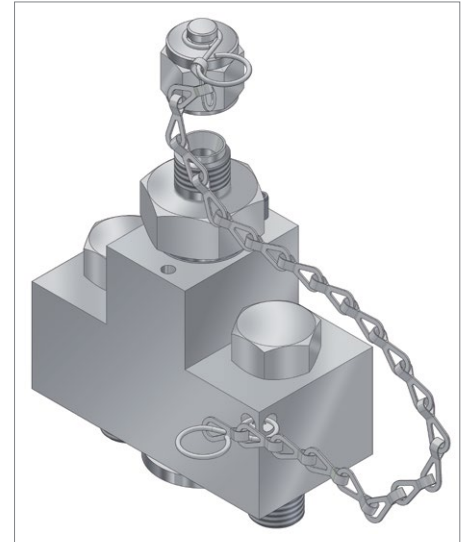

## Ordering Code

MESC CODE	DESCRIPTION	AS-Schneider P/N
MESC 60.98.90.106.1	Filling Connector 6 mm	SAF-A00-SP*1
MESC 60.98.90.107.1	Filling Connector 1/4"	SAF-A00-SP*7

\* Compression Fitting - make, type, size and composition as specified in the requisition/indent.

## Ordering Information | Filling Connector SAF

	1	2	3	4	5	6	7	8	9	10	11	12	13	14
	S	A	F	-	A	0	0	-	S	P	R	1		
<b>FILLING CONNECTOR</b>														
<b>MATERIAL SEALING WASHER</b>														
A	PTFE													
B	Graphite													
<b>MATERIAL</b>														
S	316 SST													
H	Alloy C-276													
M	Alloy 400													
<b>CONNECTION</b>														
P	Cap with Chain													
<b>CONNECTION TYPE</b>														
A	A-Lok®													
R	Rotarex													
S	Swagelok®													
<b>SIZE OF CONNECTION</b>														
1	6 mm													
7	1/4"													
<b>OPTIONS (if applicable)</b>														
B	Oxygen Service													
N	NACE / Sour Gas Service													
<b>ADDITIONAL OPTION (if applicable)</b>														
0	No additional Option													

SAF is supplied with SST hexagon cap screws 7/16-20 UNF x 1 1/2".

# Blind Flange SAG + Anti-Tamper T-Handle SAT

## Product Description

The Blind Flange enables standard instrument flange connections to be blanked off as required.

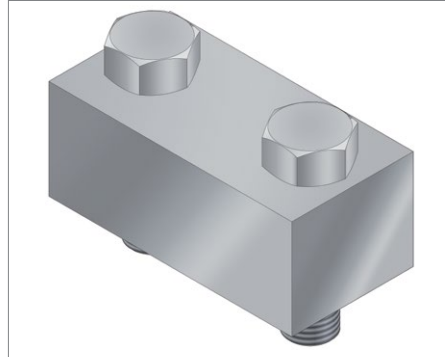

## Ordering Information | Blind Flange SAG

	1	2	3	4	5	6	7	8	9	10	11	12	13	14
	S	A	G	-	A	0	0	-	S	0	0	0		
<b>BLIND FLANGE</b>														
<b>MATERIAL SEALING WASHER</b>														
A	PTFE													
B	Graphite													
<b>MATERIAL</b>														
S	316 SST													
H	Alloy C-276													
M	Alloy 400													
<b>OPTIONS (if applicable)</b>														
B	Oxygen Service													
N	NACE / Sour Gas Service													
<b>ADDITIONAL OPTION (if applicable)</b>														
0	No additional Option													

SAG is supplied with SST hexagon cap screws 7/16-20 UNF x 1 1/2"

## Product Description

Removable T-Handle to operate the Anti-Tamper Vent Valves.

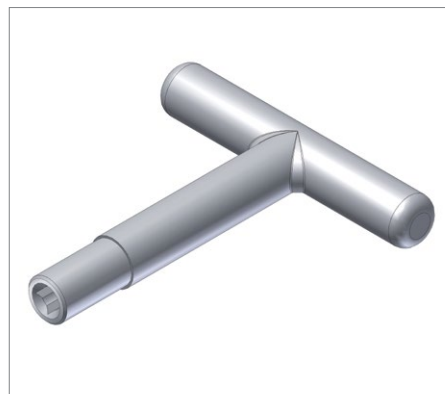

## Ordering Code

AS-Schneider P/N

SAT

# Port Protector SAD & Protective Shade and Enclosure SAP

## Product Description

The Port Protector prevents the ingress of Bugs and Dirt.



## Ordering Information | Port Protector SAD

		1	2	3	4	5	6	7	8	9
		S	A	D	-	G	2	0	-	S
<b>PORT PROTECTOR</b>										
<b>THREAD</b>										
G	G									
N	NPT									
<b>THREAD SIZE</b>										
2	1/4									
4	1/2									
<b>MATERIAL</b>										
S	316 SST									
H	Alloy C-276									
M	Alloy 400									

## Product Description

The Protective Shade SAP-P was designed to Protect the Instrument from Heavy Rain and Intensive Sunlight.

The Enclosure provides a Complete Environmental Protection of the Manifold and the Instrument Body. This is mainly used if the System is exposed to Low Temperatures.

## Ordering Code

MESC CODE	DESCRIPTION	AS-Schneider P/N
MESC 60.98.91.205.1	Protective Shade G.R.P. antistatic	SAP-PA0
	Protective Shade SST	SAP-PS0
MESC 60.98.91.305.1	Enclosure G.R.P. antistatic	SAP-EA0



SAP-PA0  
Protective Shade

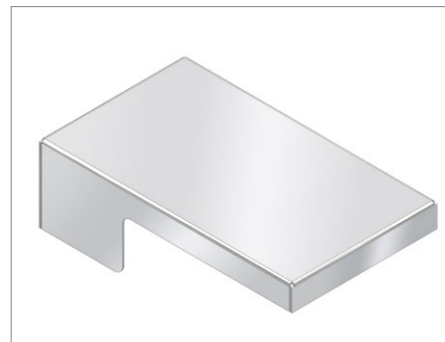

SAP-PS0  
Protective Shade



SAP-EA0  
Enclosure



## Cross Reference | Referring to the Global MESC Code

MESC CODE	DESCRIPTION	VENT	AS-Schneider P/N	PAGE	
MESC 60.98.55.200.1	Instrument Monoflange 1/2" 150-600 Type G	G 1/4-F	SMA-GLN-SG00	4 – 5	
MESC 60.98.55.210.1	Instrument Monoflange 1/2" 900-2500 Type G	G 1/4-F	SMA-GHN-SG00		
MESC 60.98.55.220.1	Instrument Monoflange 1/2" 150-600 Type G	G 1/4-F	SMA-GLG-SG00		
MESC 60.98.55.230.1	Instrument Monoflange 1/2" 900-2500 Type G	G 1/4-F	SMA-GHG-SG00		
MESC 60.98.55.300.1	Instrument Monoflange 1/2" 150-600 Type S	G 1/4-F	SMA-SLN-SG00		
MESC 60.98.55.310.1	Instrument Monoflange 1/2" 900-2500 Type S	G 1/4-F	SMA-SHN-SG00		
MESC 60.98.55.320.1	Instrument Monoflange 1/2" 150-600 Type S	G 1/4-F	SMA-SLG-SG00		
MESC 60.98.55.330.1	Instrument Monoflange 1/2" 900-2500 Type S	G 1/4-F	SMA-SHG-SG00		
MESC 60.98.56.205.1	4 Valve Manifold Type A	10mm*	SBA-AA0-SG*3	6 – 7	
MESC 60.98.56.207.1		3/8"	SBA-AA0-SG*8		
MESC 60.98.56.215.1	4 Valve Manifold Type B	10mm*	SBA-BA0-SG*3		
MESC 60.98.56.217.1		3/8"	SBA-BA0-SG*8		
MESC 60.98.56.225.1	2 Valve Manifold Type C	10mm*	SBA-CA0-SG*3		
MESC 60.98.56.227.1		3/8"	SBA-CA0-SG*8		
MESC 60.98.56.235.1	2 Valve Manifold Type D	10mm*	SBA-DA0-SG*3		
MESC 60.98.56.237.1		3/8"	SBA-DA0-SG*8		
MESC 60.98.56.305.1	2 Valve Manifold Type E	10mm*	SBA-EA0-SG*3		
MESC 60.98.56.325.1		3/8"	SBA-EA0-SG*8		
MESC 60.98.56.315.1	2 Valve Manifold Type F	10mm*	SBA-FA0-SG*3		
MESC 60.98.56.335.1		3/8"	SBA-FA0-SG*8		
MESC 60.98.56.317.1	2 Valve Manifold Type G	10mm*	SBA-GA0-SG*3		
MESC 60.98.56.337.1		3/8"	SBA-GA0-SG*8		
MESC 60.98.91.105.1	Mounting Bracket A1		SAM-A1		8
MESC 60.98.91.110.1	Mounting Bracket A2		SAM-A2		
MESC 60.98.91.118.1	Mounting Bracket B1		SAM-B1		
MESC 60.98.91.120.1	Mounting Bracket B2		SAM-B2		
MESC 60.98.70.210.1	Single Vent Purge Block Type S	10mm*	SVA-S00-SG*3	9	
MESC 60.98.70.310.1		3/8"	SVA-S00-SG*8		
MESC 60.98.70.220.1	Double Vent Purge Block Type D	10mm*	SVA-D00-SG*3		
MESC 60.98.70.320.1		3/8"	SVA-D00-SG*8		
MESC 60.98.70.510.1	Seal Pot	10mm*	SSB-000-SG*3	10	
MESC 60.98.70.600.1		1/2"	SSB-000-SG*9		
MESC 60.98.70.610.1		3/8"	SSB-000-SG*8		
MESC 60.98.70.010.1	Steam Tracing Block	10mm*	SAS-000-SG*3	11	
MESC 60.98.70.110.1		3/8"	SAS-000-SG*8		
MESC 60.98.70.050.1	Electrical Heater		SAE		
MESC 60.98.90.106.1	Filling Connector 6mm		SAF-A00-SPS1	12	
MESC 60.98.90.107.1	Filling Connector 1/4"		SAF-A00-SPS7		
	Blind Flange		SAG-A00-S000	13	
	Anti-Tamper T-Handle		SAT		
	Port Protector		SAD-G20-S		
MESC 60.98.91.205.1	Protective Shade Synthetic		SAP-PA0	14	
	Protective Shade SST		SAP-PS0		
MESC 60.98.91.305.1	Enclosure Fibreglas		SAP-EA0		

\* Compression Fitting - make, type, size and composition as specified in the requisition/indent.



# schneider

Tailored to Your Business



## Armaturenfabrik Franz Schneider GmbH + Co. KG

Bahnhofplatz 12 | 74226 Nordheim  
Deutschland / Germany

**Tel:** +49 71 33 101-0

**Fax:** +49 71 33 101-148



[www.as-schneider.com](http://www.as-schneider.com)



## AS-Schneider Asia-Pacific Pte. Ltd.

970 Toa Payoh North, #02-12/14/15  
Singapore 318992

**Tel:** +65 62 51 39 00

**Fax:** +65 62 51 39 90



[www.as-schneider.sg](http://www.as-schneider.sg)



## Armaturenfabrik Franz Schneider SRL

Sales Office:  
Str. Basarabilor, Nr. 7 | 100036 Ploiesti  
Romania

**Tel:** +40 244 384 963

**Fax:** +40 244 384 963

Production Plant:  
Str. Mihai Viteazu, Nr. 327i | 507085 Harman  
Jud. Braşov | Romania

**Tel:** +40 368 41 40 25

**Fax:** +40 368 41 40 26



[www.as-schneider.ro](http://www.as-schneider.ro)



## AS-Schneider Middle East FZE

P.O. Box 18749 | Dubai  
United Arab Emirates

**Tel:** +971 4 880 85 75

**Fax:** +971 4 880 85 76



[www.as-schneider.ae](http://www.as-schneider.ae)



## AS-Schneider America, Inc.

17421 Village Green Dr | Houston, TX 77040  
United States of America

**Tel:** +1 281 2 58 42 63

**Fax:** +1 281 5 06 79 35



[www.as-schneider.com](http://www.as-schneider.com)