



Productos de instrumentación

Adaptador de brida



Adaptador de brida

Descripción del producto

Los adaptadores de brida AS-Schneider se emplean como eslabón entre la tubería y los instrumentos. Esta construcción compacta no necesita ninguna otra pieza de conexión.

Características

Conexión 1 (Conexión de brida)

- Conexión de brida ASME B16.5 de 1/2" a 3" y de Class 150 a 2.500
- Conexión de brida EN 1092-1 de DN15 a DN80 y de PN10 a PN100

Conexión 2

- Racor de anillo cortante DIN 2353
- Modelo de rosca
- Racor con anillo de sujeción

Materiales

- Brida ASME A105 o 316/316L
- Brida DIN/EN 1.0460 o 1.4571

Opciones

- Materiales conforme a NACE MR0175/ISO 15156
- Modelo sin aceite ni grasa para oxígeno
- Certificado de inspección conforme a EN 10204

Otros modelos a petición.



FAB-QLDLN4-P

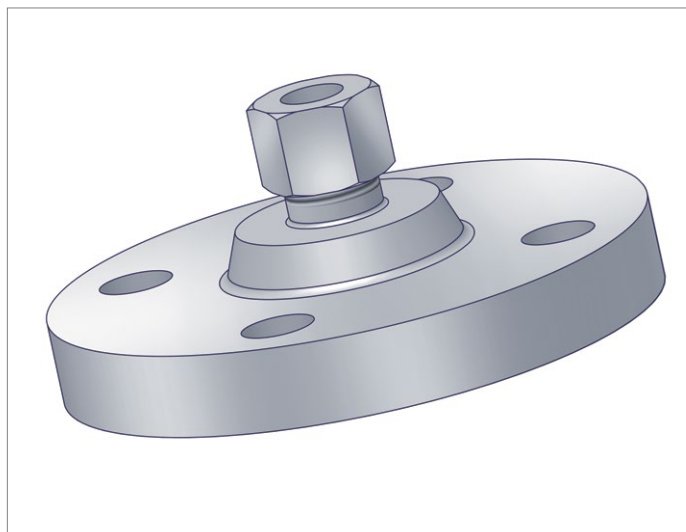

FAN-QLDG14-P

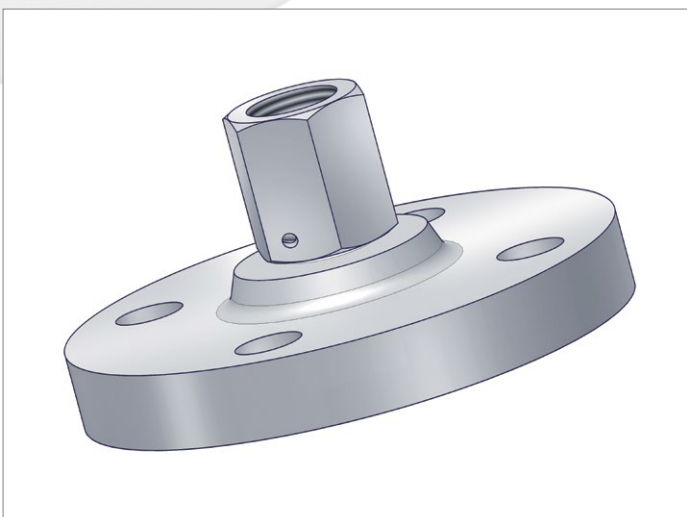

FAN-QLDLGQ-P

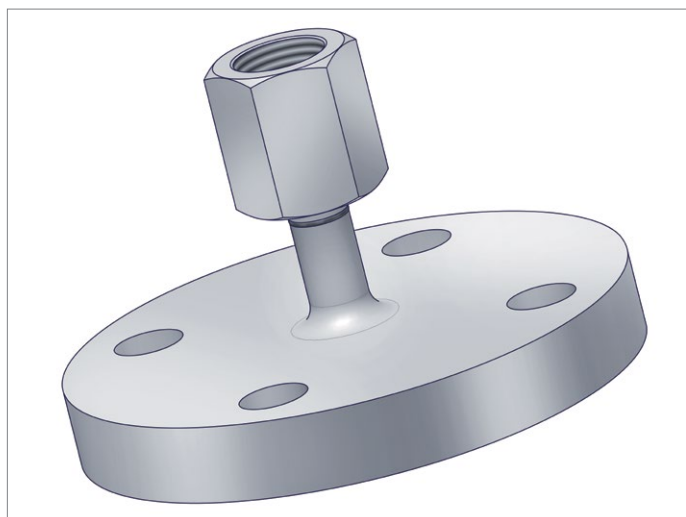

FAN-QLDLGD-P

Adaptador de brida | Información de pedido

Información de pedido | Adaptador de brida

		1	2	3	4	5	6	7	8	9	10	11	12	13	14
		F	A	N	-	N	A	A	G	1	4	-	C		
Adaptador de brida															
Brida															
N	Brida ASME														
Q	Brida EN														
Conexión 1 (Conexión de brida)															
Brida ASME		Brida EN													
A	1/2" RF	DN15 B1													
D	3/4" RF	DN15 C (lengüeta)													
F	3/4" RTJ	DN20 B1													
G	1" RF														
L		DN25 B1													
N	2" RF	DN25 B2													
P		DN25 C (lengüeta)													
Q	2" RTJ	DN25 D (ranura)													
U	3" RF														
W	3" RTJ	DN50 B1													
Z		DN80 B1													
Brida ASME		Brida EN													
A	Class 150	PN 16 (solo aplicable con \geq DN50)													
B	Class 300														
C	Class 600														
D	Class 900	PN 40													
E	Class 1500	PN 63 (solo aplicable con \geq DN50)													
F	Class 2500	PN 100													
G		PN 160													
Conexión 2															
G14	Racor con anillo cortante DIN2353 12S														
G15	Racor con anillo cortante DIN2353 14S														
LGB	Manguito giratorio G 1/4 (soldado)														
LGD	Manguito giratorio G 1/2 (soldado)														
LGN	Manguito giratorio G 1/4														
LGQ	Manguito giratorio G 1/2														
LN4	Manguito de rosca 1/2 NPT (punto 1-3 cambia en FAB)														
	Racor de anillo afianzador a petición														
Material															
Brida ASME		Brida EN													
C	A105	1.0460													
P		1.4571													
S	316L														
Opciones															
B	Sin aceite ni grasa para oxígeno														
N	NACE MR0175/ISO 15156														

Armaturenfabrik Franz Schneider GmbH + Co.KG se reserva el derecho a realizar modificaciones en los materiales, las especificaciones o los diseños sin





Armaturenfabrik Franz Schneider GmbH + Co. KG

Bahnhofplatz 12
74226 Nordheim
Deutschland / Alemania

Tel: +49 71 33 101-0
Fax: +49 71 33 101-148



www.as-schneider.com



AS-Schneider Asia-Pacific Pte. Ltd.

998 Toa Payoh North, #04-05
Singapur 318993

Tel: +65 62 51 39 00
Fax: +65 62 51 39 90



www.as-schneider.sg



Armaturenfabrik Franz Schneider SRL

Calle Mihai Viteazu N° 327i
507085 Harman, Distrito Brasov
Rumania

Tel: +40 368 41 40 25
Fax: +40 368 41 40 26



www.as-schneider.ro



AS-Schneider Middle East FZE

Apartado postal 18749
Dubái
Emiratos Árabes Unidos

Tel: +971 4 880 85 75
Fax: +971 4 880 85 76



www.as-schneider.ae