

Press release

Nordheim, 04/06/2012

ACHEMA 2012 / Hall 8.0 / Booth A85

AS-Schneider the Innovators in the field of Industrial Valves for Measurement and Control Technology

There's no doubt about it: AICHEMA is the world forum of the process industry and the trend-setting technology summit for chemical engineering, environmental protection and biotechnology. This time around, the fastest growing groups of exhibitors are measurement and control technology and the pharmaceuticals, packaging and storage technology sectors. The background to this growth is the positive way in which important sectors are developing; these include the chemical industry, the automation industry, laboratory and analysis technology and plant and mechanical engineering.

In this connection, one of the major motors is the quest to achieve solutions that are energy-efficient and have long service lives. This also applies to the fittings field for measurement and control technology. Armaturenfabrik Franz Schneider GmbH + CO. KG is present at AICHEMA 2012 too; you can find us in Hall 8.0, Booth A85 where we will be presenting our own solutions, like the innovative ISO FE-Series, as a response to this trend.

The ISO FE-Series – New valve technology for the most demanding tightness requirements

With its new ISO FE-Series, AS-Schneider has developed a new valve technology that complies with the highest ISO15848-1 tightness class "A". With a maximum permissible leak rate of 1.3×10^{-7} mbar * l/s (for a stem diameter of 7.5mm), this class even exceeds the requirements of TA-Luft.

By selecting the materials used on a targeted basis and carrying out appropriate surface treatment on them, the ISO FE-Series is even capable of coping with high pressures of 420bar (ASME class 2500) and handling a large number of switching cycles without problems. The high-strength stem thread with a hard coating guarantees safe, wear-free operation. The non-rotating shaft seal ensures low actuating forces and minimal wear to the sealing elements. The special axial bearing of the stem/tapered connection has got what it takes. It is designed such that the highest spindle forces can be absorbed without any problem.

This new valve technology is used primarily for measuring pressure and differential pressure in all types of plant engineering, particularly in chemical and petrochemical plants and the offshore industry.



Customer benefits:

- Increased plant efficiency due to
 - ✓ low medium losses
 - ✓ virtually maintenance-free operation
 - ✓ products with long service lives
- compliance with the highest requirements for leak tightness (Class A)

Bellows valves by AS-Schneider – "technically leakproof"

With very dangerous media, even the minimal ISO FE-Series leak rate can be too high. In cases like these, you can, however, use tried and tested AS-Schneider bellows valves.

To move the valve stem upwards and downwards on a leak-free basis, a multi-layer, metal bellows is used that is firmly attached on the one side to the stem and on the other side is firmly welded to the housing. This makes it impossible for the medium to escape along the valve stem.

"Technically leak-proof" properties

- Fully flushed, multi-layer stainless steel bellows valve secured against twisting, designed for 2500 operations
- Bellows completely welded to stem and housing
- Pivoted valve tip in stellite 6 material
- Safety packing
- Available pressure classes: PN100, PN250, PN400 on request



VariAS-Block

AS-Schneider developed the VariAS-Block to replace the assembly concept that has applied up to now with a compact manifold. The VariAS-Block is part of the one-piece forged Block & Bleed module for primary shut-off of pressure tapping units with which the valve is mounted directly on the tank or the process piping. In this connection, it is possible to mount or remove the instruments directly on the valve's output side.

With AS-Schneider's VariAS-Block, you are always on the safe side! The assembly solution is equipped with two independently adjustable ball valves for shutting off with a needle valve (or alternatively a ball valve) for venting: this guarantees the safety of the system.

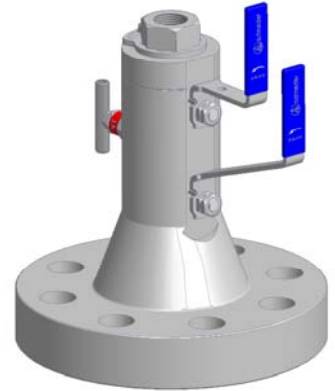

Convincing features:

- Ball bore \varnothing 20mm
- Double Block and Bleed
- One-piece, forged housing
- Fire Safe ISO 10497 / API 607

Would you like more information? Then just e-mail us at kontakt@as-schneider.com. We look forward to hearing from you.

Contact data:

Armaturenfabrik Franz Schneider GmbH + Co. KG
Anastassija Goujavina
Marketing
Bahnhofplatz 12
4226 Nordheim