

## Press release

November 11, 2013

### **A challenge with cavitation and plugged needle valves**

**Plugged needle valves and cavitation – challenges always confronting plant engineers. The AS-Schneider S371 Series can help.**

The Y-Pattern Needle Valves Type S371 are used as shut-off valves in impulse lines, where a low-resistance passage and less deflection of the flow are important, or where the valve must be easily rodded. A flow generally does not occur in impulse lines – except when blowing off or flushing the lines. But specifically while blowing off steam lines, the small flow cross sections and high pressures can result in high flow velocities, which when combined with significant deflection of flow can lead to cavitation. That cavitation damages the valve tip and the valve seat.

The AS-Schneider S371 Series was developed specifically for this application and – in contrast with many other needle valves – has a truly straight-through design without any deflection of flow. Ball valves also have these good flow characteristics, but here a metal sealed design must be used for high fluid temperatures, which is very expensive. The S371 Series thus offers the optimum compromise between the requirements of flow characteristics and valve technology.

Another advantage of the Y-Pattern Needle Valves Type S371 is the space-saving arrangement of the valve head unit relative to the impulse line – and of course the fact that it can be rodded. The S371 Series is available for pressures up to 160 bar and temperatures up to 550 °C.

#### **The most important features at a glance:**

- Forged valve body and all wetted parts made of stainless steel 1.4571 (material grade acc. to ASTM 316Ti)
- Graphite packing for use in temperatures up to 550 °C
- Bore size 8 mm (fully roddable)
- Stem with rolled threads, back seat, and a non-rotating valve tip

**Pictures: Straight Pattern Needle Type Globe Valves | Y-Pattern Needle Valves Type S371**

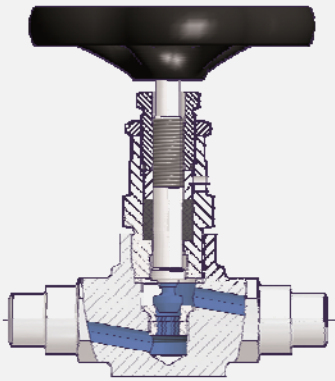

**Straight Pattern Needle Type Globe Valves:**  
The stem is vertical to the flow direction. The flow must therefore be deflected by about 90° twice. This results in high pressure losses.

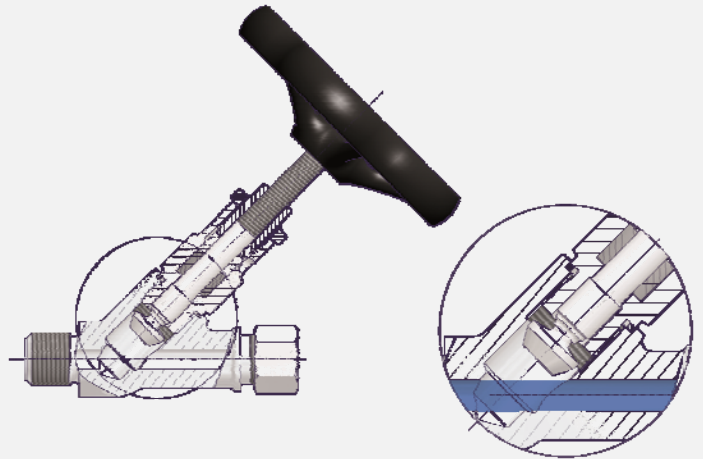

**Y-Pattern Needle Valves Type S371:**  
Minimize flow velocities and, therefore, decrease the erosive forces which shorten the life of the valve tip and seat. The valve can also be rodded if plugged.

**Want more information? Then contact us at [contact@as-schneider.com](mailto:contact@as-schneider.com).  
We look forward to hearing from you.**

**Contact data:**  
Armaturenfabrik Franz Schneider GmbH + Co. KG  
Anastassija Kinstler  
Marketing  
Bahnhofplatz 12  
74226 Nordheim  
Germany