

## Instrumentation Products

Mini Valves and Rupture Disc Holders

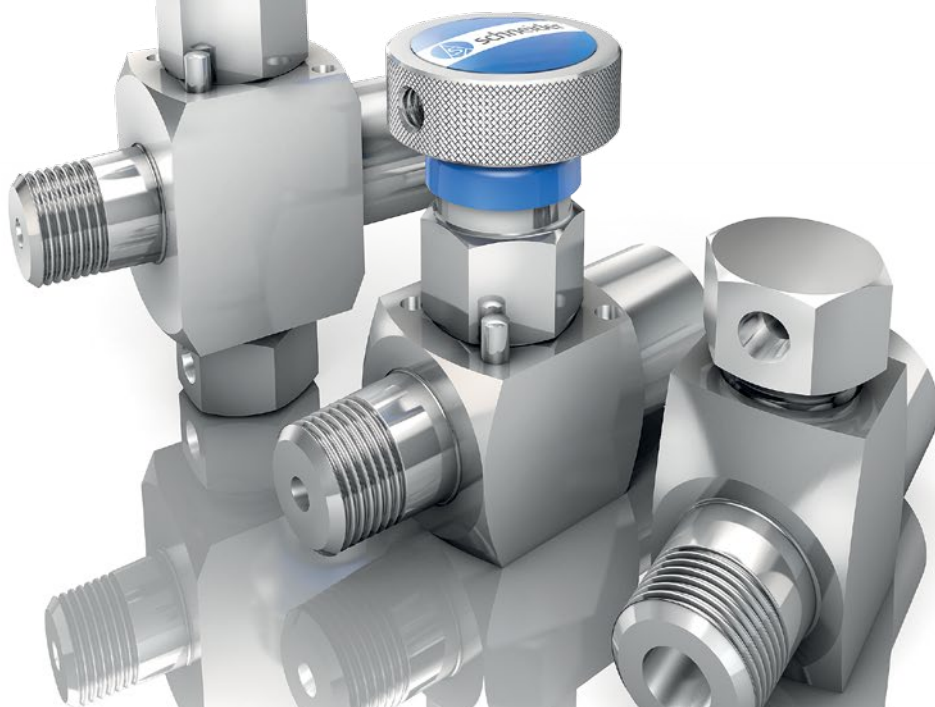

# General Features I Mini Valves and Rupture Disc Holders

## Introduction

Rugged Design for long term performance in the most demanding environmental conditions and services. Seat and Seal materials are available for hot, cold, wet, freezing, dirty sour gas (H<sub>2</sub>S), carbon dioxide (CO<sub>2</sub>), amines, corrosion inhibitors, methanol and glycol compounds found in your pipeline and transmission system. Available with Double O-Ring Stem Seal or PTFE packed. Features like Stem Seal below threads and Back Seat Design are standard. The Soft Seats are field replaceable. The valve is also available with an Integral Rupture Disc (1,800 psi [124 bar] rated). Rupture Disc Holders are available with or without Rupture Disc.

## Body Material Options

Material Group	AS Material Designation	Material Grade acc. to ASTM	Equivalent UNS-No.	Material No.	Short Name	Mini Valves	Rupture Disc Holders
Copper Alloys	Brass			CW614N	CuZn39Pb3	Standard	Not available
				CW617N	CuZn40Pb2		
Carbon Steel	LF2	LF2				Standard	Standard
Austenitic Stainless Steel	316 quadruple certified*	316	S 31600	1.4401	X5CrNiMo17-12-2	Standard	Standard
		316L	S 31603	1.4404	X2CrNiMo17-12-2		
Nickel Based Alloys	Alloy 400		N 04400	2.4360	NiCu30Fe	Optional	Optional
	Alloy C-276		N 10276	2.4819	NiMo 16 Cr 15 W	Optional	Optional

\* Quadruple Certified means acc. to ASTM and EN: 316 / 316L / 1.4401 / 1.4404

## Standard Features

- Bore Size 0.138" (3.5 mm)
- Soft Seated
- Stem Seal
  - Double O-Ring Design as standard
  - PTFE Packing is also available for all valve types
- Standard Rupture Disc 1,800 psi (124 bar) rated

### Sour Gas Service:

Wetted Parts according to a. m. material list are supplied as standard according to NACE MR0175/MR0103 and ISO 15156 (latest issue).

### Pressure Test:

A shell test and a seat leakage test are performed at 1.5 times the maximum working pressure acc. to EN 12266-1 - P10, P11 and P12 respectively MSS-SP61 (and complies also with ASME B31.1 and B31.3). As standard AS-Schneider Mini Valves are 100% Pressure Tested!

## Pressure-Temperature Rating (Soft Seat)

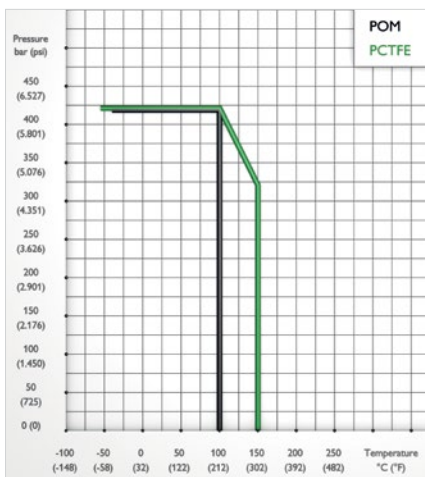

## Optional Features

### Oxygen Service:

AS-Schneider offers an option cleaned and lubricated for Oxygen Service:

PTFE Packing - Max. 6,092 psi (420 bar)

Pressure-Temperature Rating: max. 6,092 psi @ 140°F

420 bar @ 60°C

max. 392°F @ 1,305 psi

200°C @ 90 bar

Not every Valve type is available for Oxygen Service!

### Certification:

Certified Mill Test Report (CMTR) as Inspection certificate 3.1 acc. to EN 10 204 for valve body material and pressure test available on request.

If you don't find your options in this catalogue, please contact the factory.

## Stem Seal Material

Material	Temperature	
	Min.	Max.
FKM	-13°F (-25°C)	392°F (200°C)
FKM (RGD resistant)	-35°F (-37°C)	450°F (232°C)
FEPM	-4°F (-20°C)	392°F (200°C)
PTFE	-67°F (-55°C)	450°F (232°C)

Temperature Limit for Body Material:

- Carbon Steel LF2: -51°F (-46°C)

- Brass: 14°F (-10°C)

All other materials are limited by soft goods.

Max. Operating Pressure for Brass Type 3,000 psi (206.80 bar)

## Mini Valves

### Double O-Ring Stem Seal

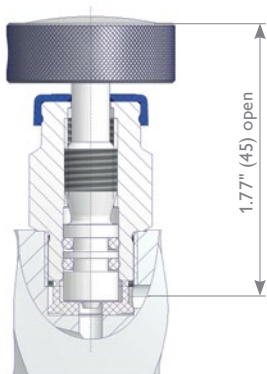

### Integral Rupture Disc

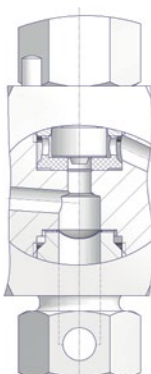

### PTFE Packing

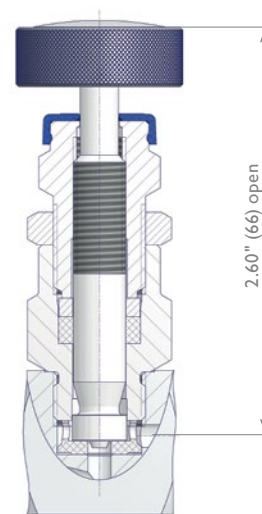

### Features

- Bore Size 0.138" (3.5 mm)
- Replaceable Valve Seat - POM, optional PCTFE
- Stem Seal - O-Rings in FKM (optional RGD resistant) or FEPM
- External Stem Thread - Packing below stem threads. Stem Threads are protected from process media (non-wetted).
- Stem with Cold Rolled Threads, except Brass Type
- Blow-out Proof Stem
- Back Seat - Metal to metal secondary stem seal
- Lock Pin - Eliminates unauthorized removal of the bonnet
- Color Coded Dust Cap for operating thread protection
- Type with Integral Rupture Disc optional
- Round Handle Aluminium, silver anodized -  
Optional Round Handle & T Handle in 316SS
- Max. Operating Pressure 6,092 psi (420 bar)

### Mini Valves are manufactured to the following Codes and Specifications

- ASME B31.1 Power Piping
- ASME B31.3 Process Piping
- ASME B16.34 Valves - Flanged, Threaded and Welding End
- API 598 Valve Inspection and Testing
- MSS SP-25 Standard Marking Systems for Valves, Fittings and Flange Unions
- MSS SP-99 Instrument Valves
- MSS SP-105 Instrument Valves for Code Applications
- NACE MR0175 Petroleum and Natural Gas Industries ...  
(not available for brass valves)

Components	Brass	Carbon Steel	Stainless Steel	Exotic Alloys	
	Material / Material No.				
<b>Body</b>	Brass	LF2	316 / 316L	Alloy 400	Alloy C-276
<b>Bonnet</b>		316 / 316L	Alloy 400	Alloy C-276	
<b>Seat</b>	POM or PCTFE				
<b>Valve Stem</b>	Brass	316 / 316L		Alloy 400	Alloy C-276
<b>O-Ring</b>	FKM or FEPM				
<b>Packing</b>	PTFE				
<b>Rupture Disc</b>	Alloy 625				
Hex Plug	316				
Gland	316				
Stem Nut	316				
Lock Nut	316				
Set Screw	316				
Round Handle	Aluminium				
Lock Pin	A4 (316)				

Wetted components listed in bold.



**Packing adjustment may be required during the service life of the valve.**



**Valves that have not been cycled for a period of time may have a higher initial actuation torque.**



## Straight Pattern

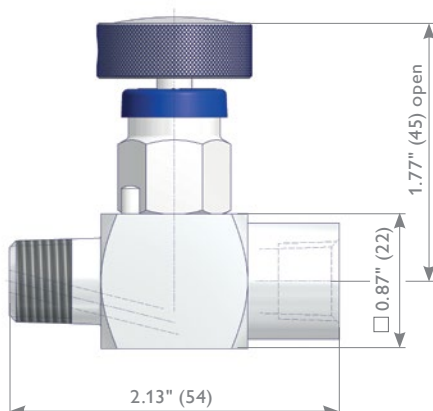

## Angle Pattern

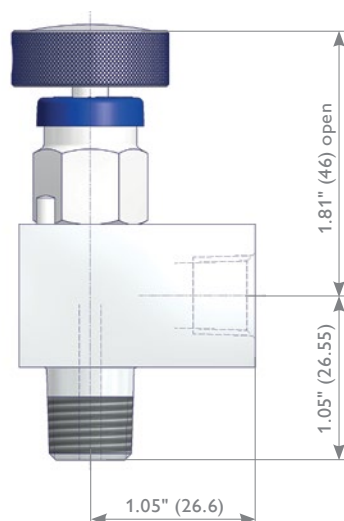

## Straight Pattern and Integral Rupture Disc

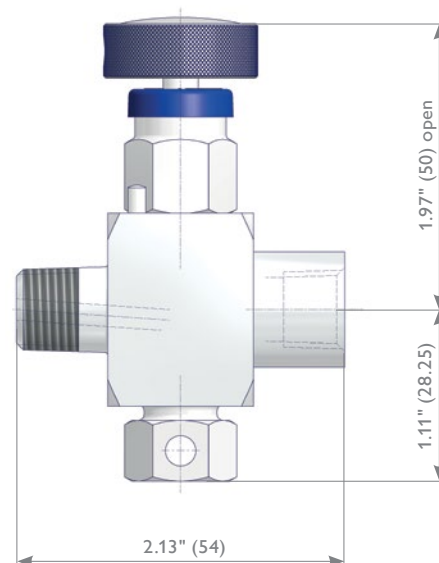

## Ordering Information

	1	2	3	4	5	6	7	8	9	10	11	12	13	14	15	16
	A	5	S	-	A	N	2	S	K	D	-	B				
<b>A5 Mini Valves</b>																
<b>Basic Design</b>																
S	Straight Pattern			L Angle Pattern												
R	Straight Pattern + Integral Rupture Disc															
<b>Dash</b>																
<b>Inlet x Outlet Configuration</b>																
A	Male x Female			C Male x Male												
B	Female x Female															
<b>Inlet and Outlet Thread Sizes</b>																
N1	1/8 NPT															
N2	1/4 NPT															
<b>Material</b>																
L	Carbon Steel LF2			M Alloy 400 UNS N04400			E Brass (not for Integral Rupture Disc Design)									
S	1.4404 / 1.4401 / 316 / 316L			H Alloy C-276 UNS N10276												
<b>Stem Seal / Packing</b>																
K	O-Ring FKM			A PTFE Packing												
J	O-Ring FKM (RGD-resistant)															
P	O-Ring FEPM															
<b>Seat Material</b>																
D	POM															
K	PCTFE															
<b>Dash</b>																
<b>Options - Specify in alphabetical order (digits first, then letters)</b>																
18	Valve with Integral Rupture Disc: Assembled with Standard Rupture Disc 1,800 psi (124 bar) rated															
-	Valve with Integral Rupture Disc: Assembled with Rupture Disc ___00 psi rated   ___00 psi ___ to be specified															
B	Cleaned and Lubricated for Oxygen Service															
M	Wetted Parts with Certified Mill Test Report (CMTR) as 3.1 certificate acc. to EN 10204															
<b>Operation Options</b>																
K	T Handle - Instead of Round Handle Aluminium															
W	Round Handle SS - Instead of Aluminium															

Wetted Parts according to above mentioned material list are supplied according to NACE MR0175/MR0103 and ISO 15156 (latest issue).

# Rupture Disc Holders

## Rupture Disc Holders

### Features

- Standard Rupture Disc 1,800 psi (124 bar) rated

Components	Carbon Steel	Stainless Steel	Exotic Alloys	
	Material / Material No.			
<b>Body</b>	LF2	316 / 316L	Alloy 400	Alloy C-276
<b>Rupture Disc</b>	Alloy 625			
<b>Hex Plug</b>	316			

Wetted components listed in **bold**.

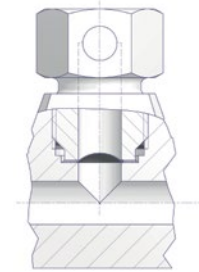

**Male x Female**

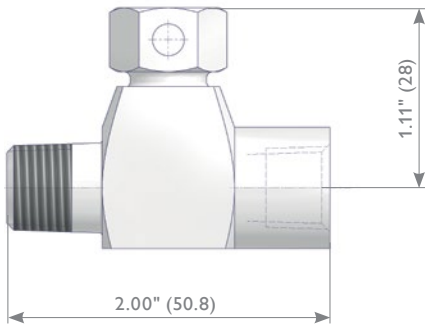

**Female x Female**

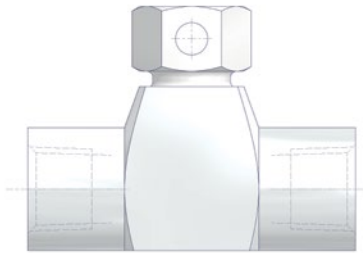

**Male x Male**

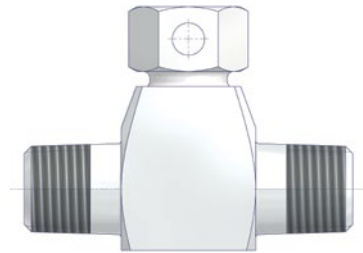

## Ordering Information

	1	2	3	4	5	6	7	8	9	10	11	12	13	14	15	16
	R	D	H	-	A	N	2	S	-	A						
<b>RDH Rupture Disc Holders</b>																
<b>Dash</b>																
<b>Inlet x Outlet Configuration</b>																
A	Male x Female				C	Male x Male										
B	Female x Female															
<b>Inlet and Outlet Thread Sizes</b>																
N2	1/4 NPT															
<b>Material</b>																
L	Carbon Steel LF2				M	Alloy 400 UNS N04400										
S	1.4404 / 1.4401 / 316 / 316L				H	Alloy C-276 UNS N10276										
<b>Dash</b>																
<b>Options - Specify in alphabetical order (digits first, then letters)</b>																
A	Rupture Disc Holder without Rupture Disc															
18	Assembled with Standard Rupture Disc 1,800 psi (124 bar) rated															
__	Assembled with Rupture Disc ___00 psi rated   ___00 psi ___ to be specified															
B	Cleaned for Oxygen Service															
M	Wetted Parts with Certified Mill Test Report (CMTR) as 3.1 certificate acc. to EN 10204															

Wetted Parts according to above mentioned material list are supplied according to NACE MR0175/MR0103 and ISO 15156 (latest issue).

Continuous product development may from time to time necessitate changes in the details contained in this catalogue. AS-Schneider reserves the right to make such changes at their discretion and without prior notice. All dimensions shown in this catalogue are approximate and subject to change.



# schneider

Tailored to Your Business



**Armaturenfabrik Franz Schneider  
GmbH+Co.KG**

Bahnhofplatz 12 | 74226 Nordheim  
Deutschland/Germany

**Tel:** +49 71 33 101-0

**Fax:** +49 71 33 101-148



[www.as-schneider.com](http://www.as-schneider.com)



**AS-Schneider Asia-Pacific Pte. Ltd.**

970 Toa Payoh North, #02-12/14/15  
Singapore 318992

**Tel:** +65 62 51 39 00

**Fax:** +65 62 51 39 90



[www.as-schneider.sg](http://www.as-schneider.sg)



**Armaturenfabrik Franz Schneider SRL**

Sales Office:  
Str. Basarabilor, Nr. 7 | 100036 Ploiesti  
Romania

**Tel:** +40 244 384 963

**Fax:** +40 244 384 963

Production Plant:  
Str. Mihai Viteazu, Nr. 327i | 507085 Harman  
Jud. Braşov | Romania

**Tel:** +40 368 41 40 25

**Fax:** +40 368 41 40 26



[www.as-schneider.ro](http://www.as-schneider.ro)



**AS-Schneider Middle East FZE**

P.O. Box 18749 | Dubai  
United Arab Emirates

**Tel:** +971 4 880 85 75

**Fax:** +971 4 880 85 76



[www.as-schneider.ae](http://www.as-schneider.ae)



**AS-Schneider America, Inc.**

17421 Village Green Dr | Houston, TX 77040  
United States of America

**Tel:** +1 281 2 58 42 63

**Fax:** +1 281 5 06 79 35



[www.as-schneider.com](http://www.as-schneider.com)