

LISTEN.
THINK.
SOLVE.SM

BULLETIN 193 E1 Plus DeviceNet™ Module

CATALOG NUMBER 193-EDN

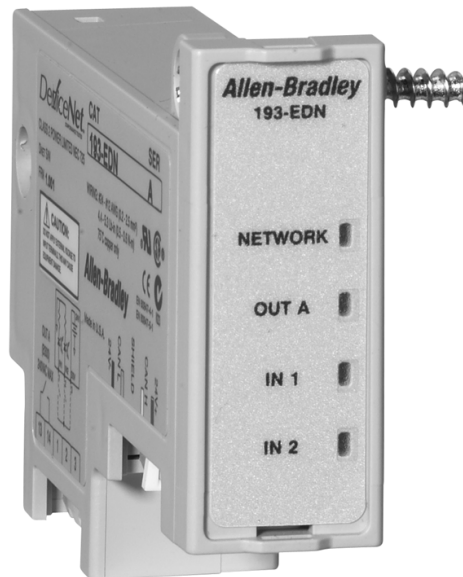

Important User Information

Solid state equipment has operational characteristics differing from those of electromechanical equipment. *Safety Guidelines for the Application, Installation and Maintenance of Solid State Controls* (Publication SGI-1.1 available from your local Rockwell Automation sales office or online at <http://www.ab.com/manuals/gi>) describes some important differences between solid state equipment and hard-wired electromechanical devices. Because of this difference, and also because of the wide variety of uses for solid state equipment, all persons responsible for applying this equipment must satisfy themselves that each intended application of this equipment is acceptable.

In no event will Rockwell Automation, Inc. be responsible or liable for indirect or consequential damages resulting from the use or application of this equipment.

The examples and diagrams in this manual are included solely for illustrative purposes. Because of the many variables and requirements associated with any particular installation, Rockwell Automation, Inc. cannot assume responsibility or liability for actual use based on the examples and diagrams.

No patent liability is assumed by Rockwell Automation, Inc. with respect to use of information, circuits, equipment, or software described in this manual.

Reproduction of the contents of this manual, in whole or in part, without written permission of Rockwell Automation, Inc. is prohibited.

Throughout this manual, when necessary we use notes to make you aware of safety considerations.

WARNING

Identifies information about practices or circumstances that can cause an explosion in a hazardous environment, which may lead to personal injury or death, property damage, or economic loss.

IMPORTANT

Identifies information that is critical for successful application and understanding of the product.

ATTENTION

Identifies information about practices or circumstances that can lead to personal injury or death, property damage, or economic loss. Attentions help you:

- identify a hazard
 - avoid a hazard
 - recognize the consequence
-

SHOCK HAZARD

Labels may be located on or inside the equipment (e.g., drive or motor) to alert people that dangerous voltage may be present.

BURN HAZARD

Labels may be located on or inside the equipment (e.g., drive or motor) to alert people that surfaces may be dangerous temperatures.

Chapter 1 — Installation and Wiring	Introduction	1-1
	Features.	1-3
	Installation	1-4
	Wiring.	1-5
	Dimensions.	1-6
Chapter 2 — Protection Functions	Introduction	2-1
	Trip Status / Identification	2-1
	Trip Resetting.	2-1
	Trip and Warning Enable	2-1
	Overload and Phase Loss Protection	2-2
	Overload Warning.	2-2
	Jam Protection	2-3
	Jam Trip	2-3
	Jam Warning.	2-4
	Underload Protection.	2-4
	Underload Warning	2-5
	Communication Fault Protection	2-5
	Comm Fault Warning	2-5
	Communication Idle Protection	2-6
	Comm Idle Warning	2-6
Chapter 3 — DeviceNet Node Commissioning	Using RSNetWorx for DeviceNet.	3-1
	Going Online.	3-1
	Building and Registering an EDS File	3-2
	Produced and Consumed Assembly Configuration.	3-6
	Mapping to the Scanner's Scan List	3-7
	Commissioning the Protection Functions	3-8
Chapter 4 — Device Parameters	Introduction	4-1
	Parameter Programming	4-1
	Program Lock	4-1
	Resetting to the Factory Default Values.	4-1
	Parameter Group Listing.	4-2
	Monitor Group	4-2
	Advanced Setup Group.	4-5
	Reset/Lock Group.	4-9
	DeviceNet Setup Group	4-10
	I/O Setup Group.	4-12
Trip History Group.	4-14	
Chapter 5 — Troubleshooting	Introduction	5-1
	DeviceNet Modes of Operation	5-2
	Power-Up Reset Mode	5-2
	Run Mode.	5-2
	Recoverable Error Mode.	5-3
	Unrecoverable Error Mode.	5-3
	DeviceNet Troubleshooting Procedures	5-4
	Input and Output Troubleshooting Procedures.	5-5
	Trip and Warning Troubleshooting Procedures.	5-7

Appendix A — Specifications	A-1
Appendix B — DeviceNet Information	
Electronic Data Sheets	B-1
DeviceNet Objects	B-1
Identity Object — CLASS CODE 0x0001	B-2
Message Router — CLASS CODE 0x0002	B-3
DeviceNet Object — CLASS CODE 0x0003	B-3
Assembly Object — CLASS CODE 0x0004	B-4
Connection Object — CLASS CODE 0x0005	B-7
Discrete Input Point Object — CLASS CODE 0x0008	B-10
Discrete Output Point Object — CLASS CODE 0x0009	B-10
Parameter Object — CLASS CODE 0x000F	B-12
Parameter Group Object — CLASS CODE 0x0010	B-13
Control Supervisor Object — CLASS CODE 0x0029	B-14
Acknowledge Handler Object — CLASS CODE 0x002B	B-16
6.12. Overload Object — CLASS CODE 0x002C	B-17
DeviceNet Interface Object — CLASS CODE 0x00B4	B-17
ODVA Fault Codes	B-19
Rockwell Automation Support	1-21
Installation Assistance	1-21
New Product Satisfaction Return	1-21

Installation and Wiring

Introduction

The purpose of this chapter is to provide the necessary instructions to successfully install a 193-EDN DeviceNet Module to an E1 Plus Overload Relay and properly connect to a DeviceNet network.

ATTENTION

To prevent electrical shock, disconnect from power source before installing or servicing. Install in suitable enclosure. Keep free from contaminants.

ATTENTION

The side mount module contains ESD (electrostatic discharge) sensitive parts and assemblies. Static control precautions are required when installing, testing, servicing, or repairing this assembly. Component damage may result if ESD control procedures are not followed. If you are not familiar with static control procedures, refer to Rockwell Automation publication 8000-4.5.2, “*Guarding Against Electrostatic Damage*”, or any other applicable ESD protection handbook.

ATTENTION

The purpose of this document is to serve as a guide for proper installation. The National Electrical Code and any other governing regional or local code will take precedence. Rockwell Automation cannot assume responsibility for the compliance or proper installation of the side mount module or associated equipment. A hazard of personal injury and/or equipment damage exists if codes are ignored during installation.

ATTENTION

An incorrectly applied or installed side mount module can result in damage to the components or reduction in product life. Wiring or application errors such as supplying incorrect or inadequate supply voltage, or operating/storing in excessive ambient temperatures may result in malfunction of the product.

ATTENTION



Only personnel familiar with the side mount module and associated machinery should plan to install, set up, and maintain the system. Failure to comply may result in personal injury and/or equipment damage.

ATTENTION



This is a Class A product. In a domestic environment, this product may cause radio interference, in which case, the user may be required to take adequate measures.

ATTENTION



To remain compliant with UL/CSA certification, the DeviceNet power supply must meet NEC Class 2 requirements.

Features

Figure 1.1 Features

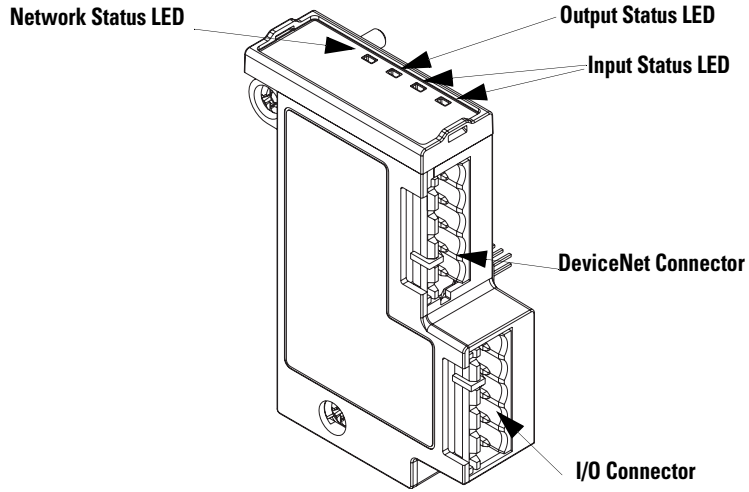

Installation

Figure 1.2 Installation [1]

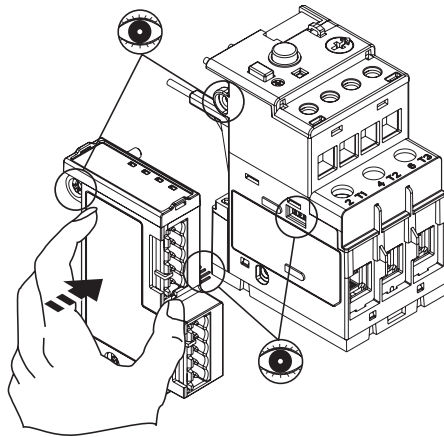

Figure 1.3 Installation [2]

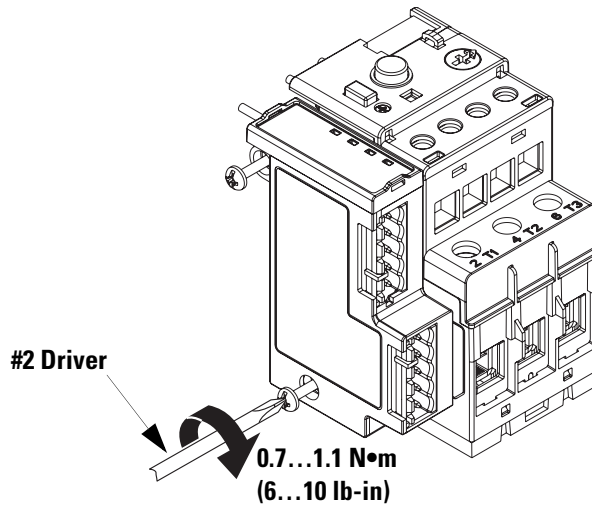
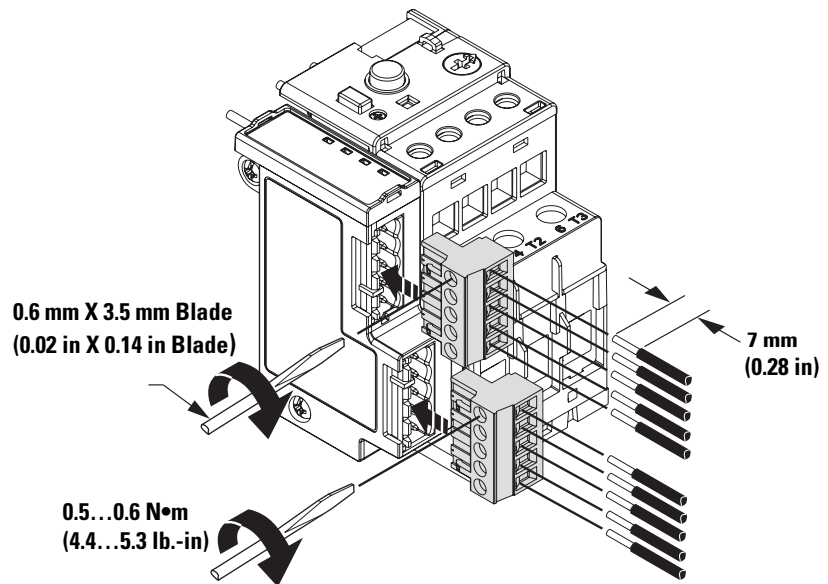

Figure 1.4 Installation [3]



Wiring

ATTENTION



When using 4-conductor DeviceNet media cable (without a shield), it is recommended that the “Shield” terminal be wired to earth ground.

Table 1.1 Wire and Size Torque Specifications

	1X	24...12 AWG
	2X	24...16 AWG 5 lb.-in
	1X	0.2...2.5 mm ²
	2X	0.25...1 mm ² 0.55 N•m
	1X	0.2...2.5 mm ²
	2X	0.2...1 mm ² 0.55 N•m

Figure 1.5 Wiring Diagram

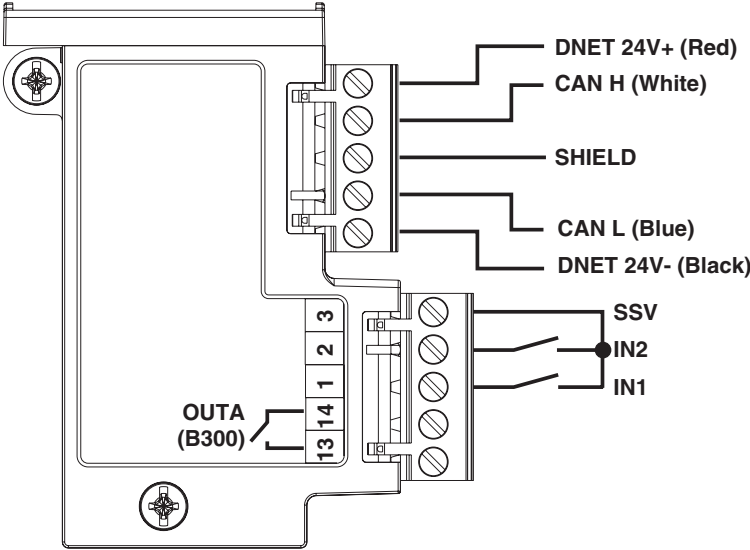

Dimensions

Figure 1.6 Dimension Diagram

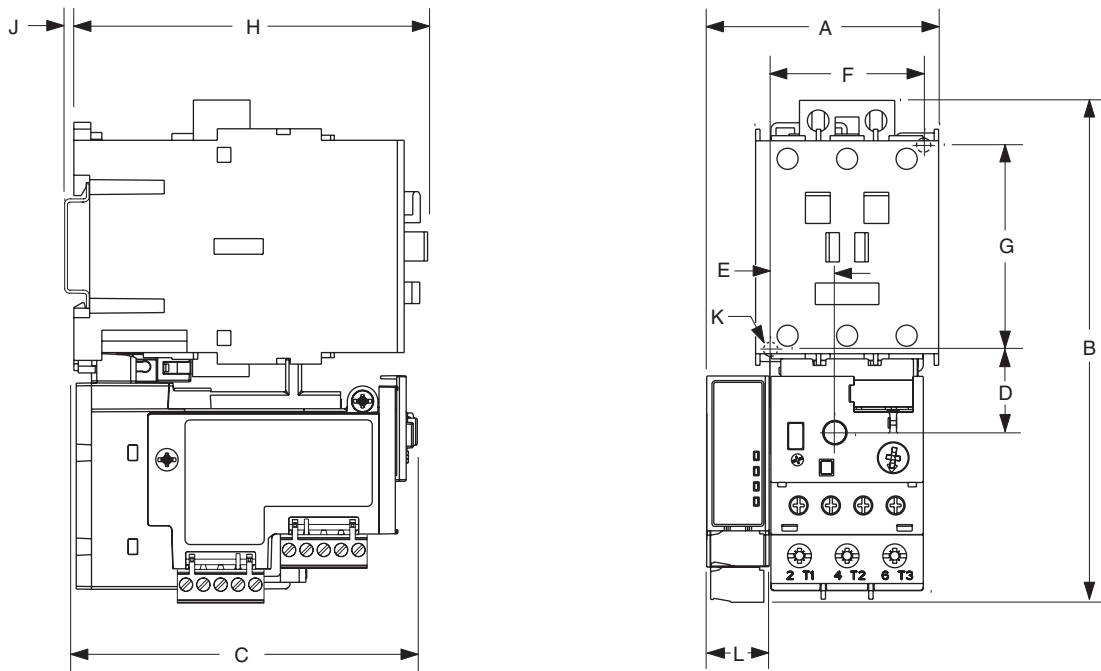

Table 1.2 Dimension Specifications

Contactor Cat. No.	E1 Plus Cat. No.	A	B	C	D	E	F	G	H	J	K	L
100-C09, -C12, -C16, -C23	193*-EE_B	63 mm (2.48 in)	148 mm (4.83 in)	85.2 mm (3.35 in)	24.5 mm (0.96 in)	13.9 mm (0.55 in)	35 mm (1.38 in)	60 mm (2.36 in)	86.5 mm (3.40 in)	2 mm (0.08 in)	4.5 mm (0.17 in)	18 mm (0.71 in)
100-C30, -C37	193*EE_D	63 mm (2.48 in)	148 mm (5.83 in)	101.2 mm (3.98 in)	24.5 mm (0.96 in)	13.9 mm (0.56 in)	35 mm (0.55 in)	60 mm (2.36 in)	104 mm (4.09 in)	2 mm (0.08 in)	4.5 mm (0.17 in)	18 mm (0.71 in)
100-C43		67.5 mm (2.66 in)	148 mm (5.83 in)	101.2 mm (3.98 in)	24.5 mm (0.96 in)	18.4 mm (0.74 in)	45 mm (1.77 in)	60 mm (2.36 in)	104 mm (4.09 in)	2 mm (0.08 in)	4.5 mm (0.17 in)	18 mm (0.71 in)
100-C60, -C72, -C85	193*-EE_E	90 mm (3.54 in)	191.6 mm (7.54 in)	120.4 mm (4.74 in)	29 mm (1.14 in)	23.8 mm (0.94 in)	55 mm (2.16 in)	100 mm (3.94 in)	126 mm (4.94 in)	2 mm (0.08 in)	5.4 mm (0.21 in)	18 mm (0.71 in)

Protection Functions

Introduction

The purpose of this chapter is to provide detailed information regarding the protective trip and warning functions that the 193-EDN DeviceNet Module adds to the E1 Plus Overload Relay. In this chapter, you will find considerable mention given to parameters as they relate to these functions. For complete descriptions of the programming parameters, refer to Chapter 4 - *Device Parameters*.

Trip Status / Identification

The DeviceNet Module determines trip status and identification through monitoring of reference signals inside the E1 Plus Overload Relay. On power-up, it assumes that the E1 Plus Overload Relay is in a non-tripped condition. For definitive feedback on trip status of the E1 Plus Overload Relay, one of the DeviceNet module inputs may be wired to the N.O. auxiliary contact (terminals 97 and 98) of the E1 Plus Overload Relay. Parameters 40 and 41 are used to configure the assignment of the inputs. For this function, use the “OL Contact” configuration.

Trip Resetting

The following options are available for resetting a tripped E1 Plus Overload Relay with a DeviceNet module:

- Blue mechanical reset button located on the front of the E1 Plus Overload Relay
- Setting Parameter 14, *Trip Reset*, to “Reset”
- Setting the trip reset bit in an output assembly from a logic controller
- Using a push button (N.O. contact configuration) wired to one of the DeviceNet module inputs, programming the corresponding input assignment parameter (40 or 41) to “Trip Reset”

IMPORTANT

Setting parameter 16, *Reset Mode*, to “Automatic” does not result in other reset commands being ignored.

Trip and Warning Enable

Parameter 12, *Trip Enable*, allows the installer to enable or disable the jam trip protective function.

Parameter 13, *Warning Enable*, allows the installer to enable or disable the overload, jam and underload warning protective functions.

ATTENTION

The Trip Enable settings should not be altered during machine operation, as unexpected behavior could occur. This may result in an unintended actuation of controlled industrial equipment, with the potential for machine damage or serious injury to personnel.

Overload and Phase Loss Protection

Thermal overload and phase loss trip protection is provided exclusively by the E1 Plus Overload Relay. The E1 Plus Overload Relay provides uninterrupted protection to the motor, even in the event of a DeviceNet Module failure. Settings for FLA and trip class are found directly on the E1 Plus Overload Relay.

IMPORTANT

The reset mode DIP switch adjustment is overridden by the DeviceNet module parameter 16, *OL Reset Mode*, while the DeviceNet module is powered.

Overload Warning

The DeviceNet Module continuously monitors the E1 Plus Overload Relay's percentage of thermal utilization signal. Parameter 2, *%Therm Utilized*, provides this value.

Parameter 17, *OL Warn Level*, is used to adjust the setpoint to alert for an impending overload trip and is adjustable from 0...100% TCU.

The DeviceNet Module will indicate an overload warning if all the following conditions are met:

- No warning currently exists
- Overload warning is enabled
- *%Therm Utilized* is equal to or greater than *OL Warn Level*

When the overload warning conditions are satisfied, the following will occur:

- Bit 0 in Parameter 4, *Warning Status*, will go to “1”
- Bit 1 of Parameter 10, *Device Status*, will go to “1”

IMPORTANT

%Therm Utilized will stabilize at a value of approximately 88% with the motor operating continuously at rated current.

Jam Protection

Motor current greater than the motor's nameplate rating can indicate a high overload or stall condition, such as an overloaded conveyor or jammed gear. These conditions can result in overheating of the motor, and equipment damage. Rapid jam fault detection helps to minimize damage and loss of production.

By continuously monitoring the motor current level signal as a percentage of the E1 Plus Overload Relay's dial FLA setting, the DeviceNet module allows jam trip and warning capability.

Jam Trip

The following parameters are available for configuring the DeviceNet Module's jam trip performance:

- Parameter 18, *Jam Inhibit Time*, allows the installer to inhibit a jam trip from occurring during the motor starting sequence. It is adjustable from 0...250 seconds.
- Parameter 19, *Jam Trip Delay*, allows the installer to define the time period a jam condition must be present before a trip occurs. It is adjustable from 0.5...25.0 seconds.
- Parameter 20, *Jam Trip Level*, allows the installer to define the current at which the E1 Plus Overload Relay will trip on a jam. It is user-adjustable from 150...600% of the FLA dial setting.

The DeviceNet Module will command the E1 Plus Overload Relay to trip if all the following conditions are met:

- No trip currently exists
- *Jam Protection* is enabled
- *Jam Inhibit Time* has expired
- The motor current is greater than the *Jam Trip Level* for a time period greater than the *Jam Trip Delay*

When the conditions for a jam trip are satisfied, the following will occur:

- Bit 2 in Parameter 3, *Trip Status*, will go to “1”
- Bit 0 in Parameter 10, *Device Status*, will go to “1”

- The E1 Plus Overload Relay's trip relay contacts (95 and 96) will open
- Out A will be placed in their Protection Fault State (if so programmed)

IMPORTANT

The Protection Fault State of OUT A is defined by parameter 34 (*OUTA Pr FltState*) and parameter 35 (*OUTA Pr FltValue*).

IMPORTANT

The jam inhibit timer starts after the load current transitions from 0 A to 30% FLA. The DeviceNet Module does not begin monitoring for a jam condition until the *Jam Inhibit Time* expires.

Jam Warning

Parameter 21, Jam Warn Level, allows the installer to define the current at which the DeviceNet Module will indicate a warning. It is user-adjustable from 100...600% FLA.

The DeviceNet Module will indicate a Jam warning if:

- No warning currently exists
- Jam Warning is enabled
- Jam Inhibit Time has expired
- The motor current is equal to or greater than the Jam Warn Level

When the Jam Warning conditions are satisfied, the following will occur:

- Bit 2 in Parameter 4, Warning Status, will go to “1”
- Bit 1 in Parameter 10, Device Status, will go to “1”

IMPORTANT

The Jam Warning function does not include a time delay feature. Once the *Jam Inhibit Time* has expired, the Jam Warning indication is instantaneous.

Underload Protection

Motor current less than a specific level may indicate a mechanical malfunction in the installation, such as a torn conveyor belt, damaged fan blade, broken shaft, or worn tool. Such conditions may not harm the motor, however, rapid detection may help to minimize equipment damage and loss of production.

Underload Warning

The following parameters are available for configuring the DeviceNet Module's underload warning performance:

- Parameter 22, *UL Inhibit Time*, allows the installer to inhibit an underload indication from occurring during the motor starting sequence. It is adjustable from 0...250 seconds.
- Parameter 23, *UL Warn Level*, allows the installer to define the current at which the DeviceNet Module will indicate a warning. It is user-adjustable from 30...100% of the FLA dial setting.

The DeviceNet Module will immediately indicate an Underload warning if:

- No warning currently exists
- *Underload Warning* is enabled
- *UL Inhibit Time* has expired
- The motor current is less than the *UL Warn Level*

When the Underload Warning conditions are satisfied, the following will occur:

- Bit 3 in Parameter 4, *Warning Status*, will go to “1”
- Bit 1 of Parameter 10, *Device Status*, will go to “1”

IMPORTANT

The Underload Warning function does not include a time delay feature. Once the *UL Inhibit Time* has expired, the Underload warning indication is instantaneous.

Communication Fault Protection

A disruption of the communication link between the E1 Plus DeviceNet Module and a DeviceNet network can result in the loss of application control and/or critical process diagnostic data. Rapid communication fault detection helps minimize potential damage due to uncontrolled or unmonitored applications.

Comm Fault Warning

The DeviceNet Module will indicate a Comm Fault warning if:

- No warning currently exists
- Comm Fault Warning is enabled
- The DeviceNet Module experiences a loss of communication

When the Comm Fault warning conditions are satisfied, the following will occur:

- The Network Status LED will blink red or become solid red
- Bit 5 in Parameter 4, *Warning Status*, will go to “1”
- Bit 1 of Parameter 10, *Device Status*, will go to “1”

IMPORTANT

The Comm Fault State of OUT A is defined by Parameter 36 (*OUTA Dn FltState*) and parameter 37 (*OUTA Dn FltValue*).

Communication Idle Protection

When a programmable controller is placed into the program mode, the execution of its ladder program is suspended, and any connected networks go to an idle state. If inadvertent, this can result in the loss of application control and/or critical process diagnostic data. Rapid communication idle detection helps minimize the potential damage due to uncontrolled or unmonitored applications.

Comm Idle Warning

The DeviceNet Module will indicate a Comm Idle warning if:

- No warning currently exists
- Comm Idle Warning is enabled
- The network controller that is communicating to the DeviceNet Module is placed in idle mode

When the Comm Idle warning conditions are satisfied, the following will occur:

- Bit 6 in Parameter 4, *Warning Status*, will go to “1”
- Bit 1 in Parameter 10, *Device Status*, will go to “1”

IMPORTANT

The Comm Idle State of OUT A is defined by Parameter 38 (*OUTA Dn IdlState*) and parameter 39 (*OUTA Dn IdlValue*).

DeviceNet Node Commissioning

Using RSNetWorx for DeviceNet

Going Online

To begin the configuration of an E1 Plus DeviceNet Module, execute the RSNetWorx software and complete the following procedure. You must use RSNetWorx Revision 3.21 Service Pack 2 or later.

1. **After** going on-line using RSNetWorx for DeviceNet, do the following:
 - Select the Network menu.
 - Select Online.
2. Choose the appropriate DeviceNet PC interface. In this example, a **1784-PCD** module is chosen. Other common DeviceNet interfaces are the 1770-KFD and 1784-PCIDS.

Note: DeviceNet drivers must be configured using RSLinx prior to being available to RSNetWorx.

3. Select **OK**.
4. RSNetWorx notifies the user to upload or download devices before viewing configuration. Select **OK**.
5. RSNetWorx now browses the network and displays all of the nodes it has detected on the network. For some versions of RSNetWorx software, the E1 Plus DeviceNet Module EDS files may not be included, and the device will be identified as an “Unrecognized Device”. If the screen appears like the following example, continue with **Building and Registering an EDS file**.

Figure 3.1 Network Online Screen

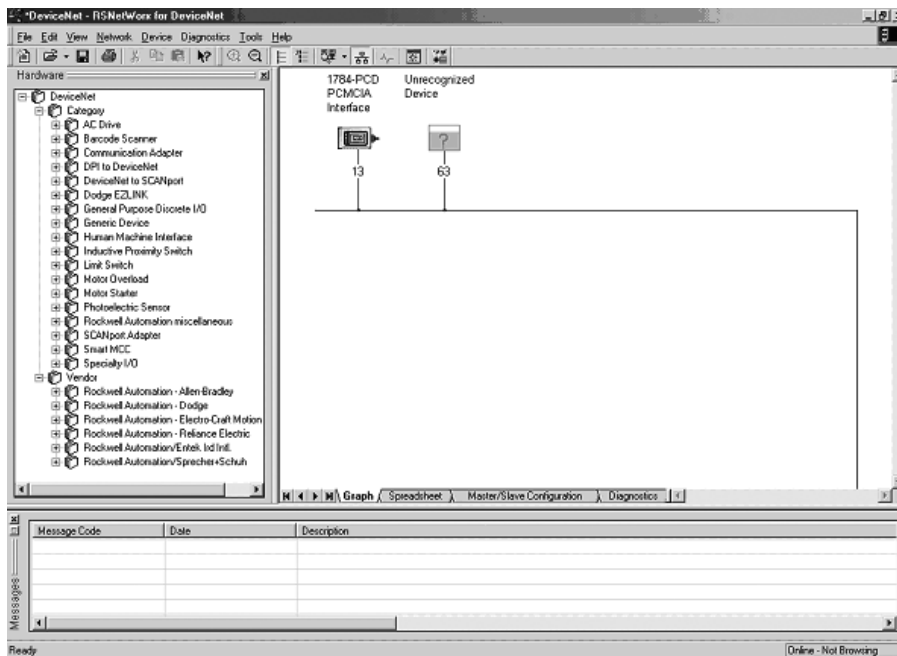

6. If RSNetWorx recognizes the device as an E1 Plus Overload Relay, skip ahead to the following section - *Using the Node Commissioning Tool of RSNetWorx for DeviceNet.*

Building and Registering an EDS File

The EDS file defines how RSNetWorx for DeviceNet will communicate to the E1 Plus DeviceNet Module. The EDS file can be created over the DeviceNet network or downloaded from the Internet.

Note: You can download the EDS file from www.ab.com/networks.eds.

Do the following to build and register the EDS file:

1. Right-click on the “Unrecognized Device” icon. Select **Register Device** from the menu that appears.
2. The EDS Wizard will appear.
3. Select **Next**.
4. Select **Create an EDS File**.
5. Select **Next**. The following screen appears:

Figure 3.2 Figure EDS Wizard Screen

6. (Optional) Do the following:
 - Type a value in **Catalog**.
 - Type a description in **File Description Text**.
7. Select *Next*.

Figure 3.3 Setting Default I/O Assembly Sizes

8. Next to the selected Polled check box, do the following:
 - Type **6** in **Input Size**.
 - Type **1** in **Output Size**.
9. Select **Next**. RSNetWorx uploads the EDS file from the E1 Plus DeviceNet Module.
10. To display the icon options for the node, select **Next**.
11. Select the E1 Plus Overload Relay icon by highlighting it and clicking **Change Icon**.
12. After selecting the desired icon, select **OK**.
13. Select **Next**.
14. When prompted to register this device, select **Next**.
15. Select **Finish**. After a short time, RSNetWorx updates the online screen by replacing “Unrecognized Device” with the name and icon given by the EDS file that you have just registered.

Using the Node Commissioning Tool of RSNetWorx for DeviceNet

1. From the **Tools** menu at the top of the screen, select **Node Commissioning**.
2. Select **Browse**.

Figure 3.4 Node Commissioning Device Solution Window

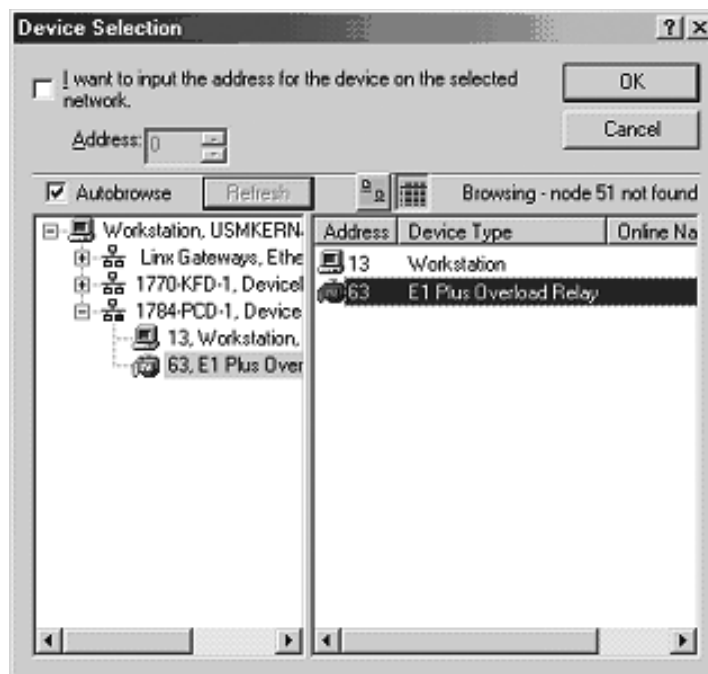

3. Select the E1 Plus Overload Relay located at node 63.
4. Select **OK**. The Node Commissioning screen shows Current Device Settings entries completed. It will also provide the current network baud rate in the New E1 Plus Overload Relay Settings area. Do not change the baud rate setting, unless you are sure it must be changed.
5. Type the node address that you want in the **New Device Settings** section. In this example, the new node address is 5.
6. To apply the new node address, select *Apply*.
7. When the new node address has been successfully applied, the Current Device Settings section of the window is updated (see the example below). If an error occurs, check to see if the device is properly powered up and connected to the network.

Figure 3.5 Node Commissioning Confirmation Window



8. To exit the node commissioning tool, select *Close*.
9. To update RSNetWorx and verify that the node address is set correctly, select *Single Pass Browse* from the **Network** menu.

Produced and Consumed Assembly Configuration

The Input and Output Assembly format for the E1 Plus Overload Relay is identified by the value in Parameter 28 (*Output Assembly*) and Parameter 29 (*Input Assembly*). These values determine the amount and arrangement of the information communicated to the master scanner.

Figure 3.6 I/O Assembly Settings

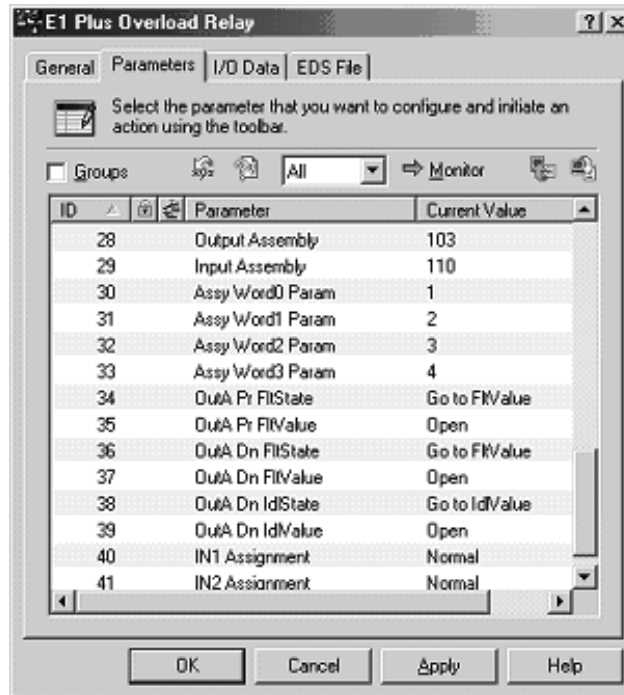

Selection of Input and Output Assemblies (also referred to as Produced and Consumed Assemblies) define the format of I/O message data that is exchanged between the E1 Overload Relay and other devices on the network. The consumed information is generally used to command the state of the slave device's outputs, and produced information typically contains the state of the inputs and the current fault status of the slave device.

The default Consumed and Produced Assemblies are shown below. For additional formats, refer to *Appendix B—DeviceNet Information*.

Table 3.1 Instance 103—E1 Plus Default Output (Consumed) Assembly

Instance 103— Similar to Basic Motor Starter Output Assembly in ODVA Starter Profile								
Byte	Bit 7	Bit 6	Bit 5	Bit 4	Bit 3	Bit 2	Bit 1	Bit 0
0						Fault Reset		OutA

Table 3.2 Instance 110—E1 Plus Default Input (Produced) Assembly

Instance 110 – Extended Motor Starter Input Assembly								
Byte	Bit 7	Bit 6	Bit 5	Bit 4	Bit 3	Bit 2	Bit 1	Bit 0
0	Motor Current		Input2	Input1		OutA Stat	Warning	Faulted
1	Unused							
2	Average %FLA							
3								
4	%Therm Utilized							
5								

Choosing the size and format of the I/O data that is exchanged by the E1 Plus Overload Relay is done by selecting Input and Output Assembly instance numbers. Each assembly has a given size (in bytes). This instance number is written to the Input Assembly and Output Assembly parameters. The different instances/formats allow for user programming flexibility and network optimization.

IMPORTANT

The Output Assembly and Input Assembly parameter values cannot be changed while the E1 Plus Overload Relay is online with a scanner. Any attempts to change the value of this parameter while online with a scanner will result in the error message “Object State Conflict.”

Mapping to the Scanner's Scan List

The Automap feature available in all Rockwell Automation scanners automatically maps the information. If the default I/O Assemblies are not used, the values must be changed in the scanner's Scan List.

Do this by selecting *Edit I/O Parameters* on the **Scan List** tab of the scanner. The following screen (Figure 3.7) then appears.

Figure 3.7 Editing Device I/O Parameters

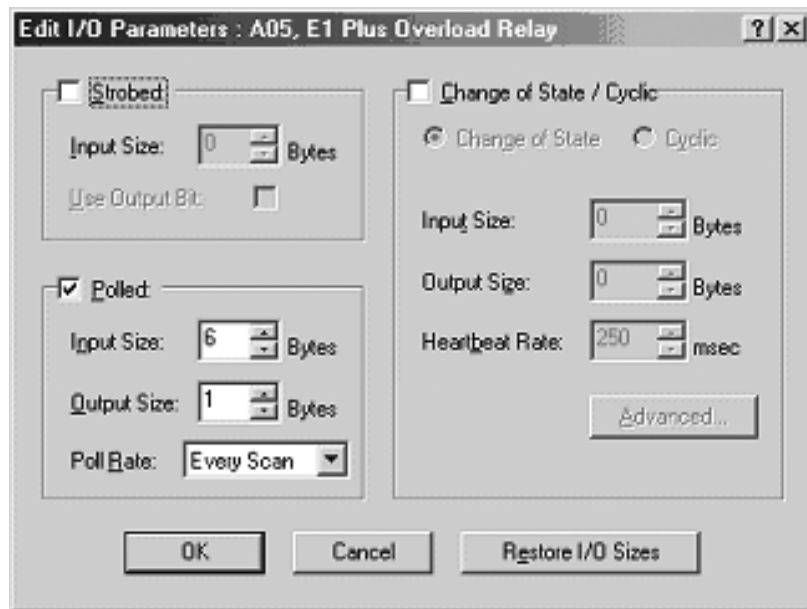

Commissioning the Protection Functions

The product should now be configured and communicating on the network. This section describes the use of RSNetWorx for DeviceNet to configure the additional protective function settings of the E1 Plus DeviceNet Module. This can also be accomplished by using a handheld DeviceNet tool.

Using the software, access the Device Parameters tab (see Figure 3.8). Type the desired setting values corresponding to the motor connected to the E1 Plus Overload Relay. Make sure that Single is the Online button selected and then select Download to Device.

Figure 3.8 RSNetWorx Parameter Screen

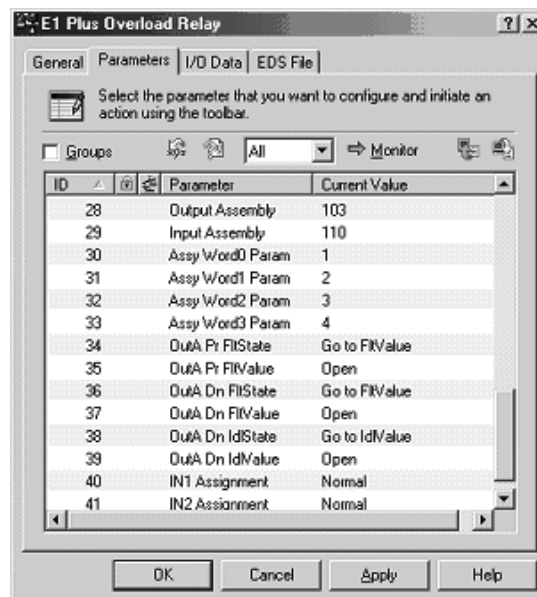

Device Parameters

Introduction

This chapter describes each programmable parameter and its function.

Parameter Programming

Refer to Chapter 3: *DeviceNet Node Commissioning* for instructions on using RSNetWorx for DeviceNet to modify parameter settings.

IMPORTANT

Parameter setting changes downloaded to the DeviceNet Module take effect immediately even during a “running” status.

IMPORTANT

Parameter setting changes made in a configuration tool, such as RSNetWorx for DeviceNet, do not take effect in the DeviceNet Module until the installer applies or downloads the new settings to the device.

Program Lock

Parameter 24, *Program Lock*, provides a degree of security from having parameter settings unintentionally altered when programmed to the “locked” setting.

Resetting to the Factory Default Values

Parameter 25, *Set to Defaults*, allows the installer to reset all parameter settings (including trip logs) to the factory default values.

IMPORTANT

Resetting to factory default values also resets the DeviceNet Module’s DeviceNet node address (MAC ID) to the default value of 63.

Parameter Group Listing

The 193-EDN DeviceNet Module contains six parameter groups

Table 4.1 Parameter Groups

Monitor parameters	Advanced Setup	Reset/Lock	DeviceNet Setup	I/O Setup	Trip History
1 Average %FLA	12 Trip Enable	14 Trip Reset	26 AutoBaudEnable	34 OutA Pr FltState	5 Trip Log 0
2%Therm Utilized	13 Warning Enable	24 Program Lock	27 NonVol Baud Rate	35 OutA Pr FltValue	6 Trip Log 1
3 Trip Status	15 Single/Three Ph	25 Set to Defaults	28 Output Assembly	36 OutA DN FltState	7 Trip Log 2
4 Warning Status	16 OL Reset Mode		29 Input Assembly	37 OutA DN FltValue	8 Trip Log 3
10 Device Status	17 OL Warning Level		30 Prod Assy Word 0	38 OutA DN IdlState	9 Trip Log 4
11 Firmware	18 Jam Inhibit Time		31 Prod Assy Word 1	39 OutA DN IdlValue	
	19 Jam Trip Delay		32 Prod Assy Word 2	40 IN1 Assignment	
	20 Jam Trip Level		33 Prod Assy Word 3	41 IN2 Assignment	
	21 Jam Warn Level				
	22 UL Inhibit Time				
	23 UL Warn Level				

Monitor Group

Average %FLA	Parameter No.	1
This parameter reports the average motor current. The value is reported as a percentage of motor rated current (dial setting on the E1 Plus Overload Relay), and is reported in increments of 5.	Access Rule	Get
	Data Type	UINT
	Group	Monitor
	Units	%FLA
	Min. Value	0
	Max. Value	1275
	Default Value	None

% Therm Utilized	Parameter No.	2
This parameter reports the percent thermal utilization of the connected motor.	Access Rule	Get
	Data Type	USINT
	Group	Monitor
	Units	%
	Min. Value	0
	Max. Value	100
	Default Value	None

Trip Status	Parameter No.	3
This parameter provides trip identification. 1 = Trip 0 = No Trip	Access Rule	Get
	Data Type	WORD
	Group	Monitor
	Units	—
	Min. Value	—
	Max. Value	—
	Default Value	None

Bit															Function:	
15	14	13	12	11	10	9	8	7	6	5	4	3	2	1	0	
															X	Overload
														X		Phase Loss
													X			Jam
X	X	X	X	X	X	X	X	X	X	X	X	X				Not Used

Warning Status	Parameter No.	4
This parameter provides warning identification 1 = Warning 0 = No Warning	Access Rule	Get
	Data Type	WORD
	Group	Monitor
	Units	—
	Min. Value	—
	Max. Value	—
	Default Value	None

Bit															Function:	
15	14	13	12	11	10	9	8	7	6	5	4	3	2	1	0	
															X	Overload
														X		Not Used
													X			Jam
											X					Underload
										X						Not Used
									X							Comm Fault
								X								Comm Idle
							X									Nonvolatile Memory Fault
X	X	X	X	X	X	X	X									Not Used

Device Status	Parameter No.	10
This parameter provides status information related to the E1 Plus Overload Relay and the DeviceNet Module. 1 = On or Present 0 = Off or Not Present	Access Rule	Get
	Data Type	WORD
	Group	Monitor
	Units	—
	Min. Value	—
	Max. Value	—
	Default Value	None

Bit																Function:
15	14	13	12	11	10	9	8	7	6	5	4	3	2	1	0	
															X	Trip
														X		Warning
													X			Out A
												X				In 1
											X					In 2
										X						Motor Current
X	X	X	X	X	X	X	X	X	X							Not Used

Firmware	Parameter No.	11
This parameter reports the firmware revision of the DeviceNet Module.	Access Rule	Get
	Data Type	UINT
	Group	Monitor
	Units	—
	Min. Value	0
	Max. Value	65535
	Default Value	None

Advanced Setup Group

Trip Enable	Parameter No.	12
This parameter allows the installer to enable or disable the Jam Trip function 1 = Enabled 0 = Disabled	Access Rule	Get/Set
	Data Type	WORD
	Group	Advanced Setup
	Units	—
	Min. Value	0000000000000000
	Max. Value	0000000000000100
	Default Value	0000000000000000

Bit															Function:	
15	14	13	12	11	10	9	8	7	6	5	4	3	2	1		0
															X	Not Used
															X	Not Used
													X			Jam
X	X	X	X	X	X	X	X	X	X	X	X	X				Not Used

Warning Enable	Parameter No.	13
This parameter allows the installer to enable or disable the warning functions separately. All warning functions are disabled from the factory. 1 = Enabled 0 = Disabled	Access Rule	Get/Set
	Data Type	WORD
	Group	Advanced Setup
	Units	—
	Min. Value	0000000000000000
	Max. Value	0000000001101101
	Default Value	0000000000000000

Bit															Function:	
15	14	13	12	11	10	9	8	7	6	5	4	3	2	1		0
															X	Overload
															X	Not Used
													X			Jam
												X				Underload
											X					Not Used
										X						Comm Fault
									X							Comm Idle
X	X	X	X	X	X	X	X	X								Not Used

Single/Three Ph	Parameter No.	15
This parameter configures the DeviceNet Module for single- or three-phase application. This parameter should be set to "Single Phase" when Bulletin 193S or 592S devices are employed.	Access Rule	Get/Set
	Data Type	BOOL
	Group	Advanced Setup
	Units	—
	Min. Value	0 = Single-Phase
	Max. Value	1 = Three-Phase
	Default Value	1

OL Reset Mode	Parameter No.	16
This parameter defines whether a trip can be automatically or manually reset. This setting overrides the E1 Plus DIP switch adjustment while the DeviceNet Module is powered. Note, however, that the E1 Plus manual reset button, accessible at the front, is always active.	Access Rule	Get/Set
	Data Type	BOOL
	Group	Advanced Setup
	Units	—
	Min. Value	0 = Manual
	Max. Value	1 = Automatic
	Default Value	0
OL Warning Level	Parameter No.	17
This parameter sets the overload warning level.	Access Rule	Get/Set
	Data Type	USINT
	Group	Advanced Setup
	Units	% Thermal Utilization
	Min. Value	0
	Max. Value	100
	Default Value	90
Jam Inhibit Time	Parameter No.	18
This parameter defines the amount of time for which jam detection is inhibited during a motor starting sequence.	Access Rule	Get/Set
	Data Type	USINT
	Group	Advanced Setup
	Units	Seconds
	Min. Value	0
	Max. Value	250
	Default Value	10
Jam Trip Delay	Parameter No.	19
This parameter allows the installer to program a time duration for which a jam condition must exist at the programmed level prior to the device tripping.	Access Rule	Get/Set
	Data Type	USINT
	Group	Advanced Setup
	Units	Seconds
	Min. Value	0.5
	Max. Value	25.0
	Default Value	5.0

Jam Trip Level	Parameter No.	20
This parameter sets the jam trip level.	Access Rule	Get/Set
	Data Type	UINT
	Group	Advanced Setup
	Units	% FLA
	Min. Value	150
	Max. Value	600
	Default Value	250
Jam Warn Level	Parameter No.	21
This parameter sets the jam warning level.	Access Rule	Get/Set
	Data Type	UINT
	Group	Advanced Setup
	Units	% FLA
	Min. Value	100
	Max. Value	600
	Default Value	150
UL Inhibit Time	Parameter No.	22
This parameter defines the amount of time for which underload detection is inhibited during a motor starting sequence.	Access Rule	Get/Set
	Data Type	USINT
	Group	Advanced Setup
	Units	Seconds
	Min. Value	0
	Max. Value	250
	Default Value	10
UL Warn Level	Parameter No.	23
This parameter sets the underload warning level.	Access Rule	Get/Set
	Data Type	USINT
	Group	Advanced Setup
	Units	% FLA
	Min. Value	30
	Max. Value	100
	Default Value	70

Reset/Lock Group

Trip Reset	Parameter No.	14
This parameter provides the user with the capability of resetting a trip over the DeviceNet network. After a trip is reset, the parameter automatically returns to a "Ready" state.	Access Rule	Get/Set
	Data Type	BOOL
	Group	Reset/Lock
	Units	—
	Min. Value	0 = Ready
	Max. Value	1 = Reset Trip
	Default Value	0
Program Lock	Parameter No.	24
This parameter prohibits the device parameters from being altered when set to "Locked". It must be set to "Unlocked" to allow parameter modification.	Access Rule	Get/Set
	Data Type	BOOL
	Group	Reset/Lock
	Units	—
	Min. Value	0 = Unlocked
	Max. Value	1 = Locked
	Default Value	0
Set To Defaults	Parameter No.	25
This parameter allows the user to reset the parameter settings to the factory default values. After parameter values have been reset to the factory default settings, the parameter automatically returns to a "Ready" state.	Access Rule	Get/Set
	Data Type	BOOL
	Group	Reset/Lock
	Units	—
	Min. Value	0 = Ready
	Max. Value	1 = Reset Defaults
	Default Value	0

DeviceNet Setup Group

AutoBaudEnable	Parameter No.	26
When this parameter is enabled, the device will attempt to determine the network baud rate and set its baud rate to the same, provided network traffic exists. At least one node with an established baud rate must exist on the network for autobaud to occur.	Access Rule	Get/Set
	Data Type	BOOL
	Group	DeviceNet Setup
	Units	—
	Min. Value	0 = Disabled
	Max. Value	1 = Enabled
	Default Value	1
NonVol Baud Rate	Parameter No.	27
This parameter allows monitoring of the communication rate setting as determined in the node commissioning tool.	Access Rule	Get
	Data Type	USINT
	Group	DeviceNet Setup
	Units	—
	Min. Value	0 = 125k 1 = 250k
	Max. Value	2 = 500k
	Default Value	0
Output Assembly	Parameter No.	28
This parameter is used to select the desired Output Assembly. See <i>Appendix B—DeviceNet Information</i> for a listing of available assemblies.	Access Rule	Get/Set
	Data Type	USINT
	Group	DeviceNet Setup
	Units	—
	Min. Value	0
	Max. Value	103
	Default Value	103
Input Assembly	Parameter No.	29
This parameter is used to select the desired Input Assembly. See <i>Appendix B—DeviceNet Information</i> for a listing of available assemblies.	Access Rule	Get/Set
	Data Type	USINT
	Group	DeviceNet Setup
	Units	—
	Min. Value	0
	Max. Value	110
	Default Value	110

Assy Word 0 Param	Parameter No.	30
This parameter assigns the parameter value to be placed in Word 0 of Input Assembly 100.	Access Rule	Get/Set
	Data Type	USINT
	Group	DeviceNet Setup
	Units	—
	Min. Value	0
	Max. Value	41
	Default Value	1
Assy Word 1 Param	Parameter No.	31
This parameter assigns the parameter value to be placed in Word 1 of Input Assembly 100.	Access Rule	Get/Set
	Data Type	USINT
	Group	DeviceNet Setup
	Units	—
	Min. Value	0
	Max. Value	41
	Default Value	2
Assy Word 2 Param	Parameter No.	32
This parameter assigns the parameter value to be placed in Word 2 of Input Assembly 100.	Access Rule	Get/Set
	Data Type	USINT
	Group	DeviceNet Setup
	Units	—
	Min. Value	0
	Max. Value	41
	Default Value	3
Assy Word 3 Param	Parameter No.	33
This parameter assigns the parameter value to be placed in Word 3 of Input Assembly 100.	Access Rule	Get/Set
	Data Type	USINT
	Group	DeviceNet Setup
	Units	—
	Min. Value	0
	Max. Value	41
	Default Value	4

I/O Setup Group

OutA Pr FltState	Parameter No.	34
This parameter, in conjunction with parameter 35, defines how Output A will respond when a trip occurs. When set to "1", Output A will continue to operate as commanded via the network. When set to "0", Output A will open or close as determined by the setting of parameter 35.	Access Rule	Get/Set
	Data Type	BOOL
	Group	I/O Setup
	Units	—
	Min. Value	0 = Go To FltValue (#35)
	Max. Value	1 = Ignore Fault
	Default Value	0

OutA Pr FltValue	Parameter No.	35
This parameter determines the state that Output A assumes when a trip occurs and Parameter 34 is set to "0".	Access Rule	Get/Set
	Data Type	BOOL
	Group	I/O Setup
	Units	—
	Min. Value	0 = Open
	Max. Value	1 = closed
	Default Value	0

OutA DN FltState	Parameter No.	36
This parameter, in conjunction with Parameter 37, defines how Output A will respond when a DeviceNet network fault occurs. When set to "1", Output A will hold the state prior to trip occurrence. When set to "0", Output A will open or close as determined by the setting of Parameter 37.	Access Rule	Get/Set
	Data Type	BOOL
	Group	I/O Setup
	Units	—
	Min. Value	0 = Go To FltValue (#37)
	Max. Value	1 = Hold Last State
	Default Value	0

OutA DN FltValue	Parameter No.	37
This parameter determines the state that Output A assumes when a DeviceNet network fault occurs and Parameter 36 is set to "0".	Access Rule	Get/Set
	Data Type	BOOL
	Group	I/O Setup
	Units	—
	Min. Value	0 = Open
	Max. Value	1 = Closed
	Default Value	0

OutA DN IdlState	Parameter No.	38
This parameter, in conjunction with parameter 39, defines how Output A will respond when the DeviceNet network is idle. When set to "1", Output A will hold the state prior to trip occurrence. When set to "0", Output A will open or close as determined by the setting in Parameter 39. The DN Flt parameters supersede the DN Idl parameters.	Access Rule	Get/Set
	Data Type	BOOL
	Group	I/O Setup
	Units	—
	Min. Value	0 = Go To IdlValue (#39)
	Max. Value	1 = Hold Last State
	Default Value	0

OutA DN IdlValue	Parameter No.	39
This parameter determines the state that Output A assumes when the network is idle and parameter 38 is set to "0".	Access Rule	Get/Set
	Data Type	BOOL
	Group	I/O Setup
	Units	—
	Min. Value	0 = Open
	Max. Value	1 = Closed
	Default Value	0

IN1 Assignment	Parameter No.	40
This parameter allows the user to assign a specific function to the discrete IN1 input.	Access Rule	Get/Set
	Data Type	USINT
	Group	I/O Setup
	Units	—
	Min. Value	0 = Normal 1 = Trip reset
	Max. Value	2 = OL Contact
	Default Value	0

IN2 Assignment	Parameter No.	41
This parameter allows the user to assign a specific function to the discrete IN2 inputs.	Access Rule	Get/Set
	Data Type	USINT
	Group	I/O Setup
	Units	—
	Min. Value	0 = Normal 1 = Trip Reset
	Max Value	2 = OL Contact
	Default Value	0

Trip History Group

Trip Log 0	Parameter No.	5
This parameter records the latest trip.	Access Rule	Get
	Data Type	WORD
	Group	Trip History
	Units	—
	Min. Value	See Trip Status table
	Max. Value	See Trip Status table
	Default Value	None

Trip Log 1	Parameter No.	6
This parameter records the trip previous to Trip Log 0.	Access Rule	Get
	Data Type	WORD
	Group	Trip History
	Units	—
	Min. Value	See Trip Status table
	Max. Value	See Trip Status table
	Default Value	None

Trip Log 2	Parameter No.	7
This parameter records the trip previous to Trip Log 1.	Access Rule	Get
	Data Type	WORD
	Group	Trip History
	Units	—
	Min. Value	See Trip Status table
	Max. Value	See Trip Status table
	Default Value	None

Trip Log 3	Parameter No.	8
This parameter records the trip previous to Trip Log 2.	Access Rule	Get
	Data Type	WORD
	Group	Trip History
	Units	—
	Min. Value	See Trip Status table
	Max. Value	See Trip Status table
	Default Value	None

Trip Log 4	Parameter No.	9
This parameter records the trip previous to Trip Log 3.	Access Rule	Get
	Data Type	WORD
	Group	Trip History
	Units	—
	Min. Value	See Trip Status table
	Max. Value	See Trip Status table
	Default Value	None

Troubleshooting

Introduction

The purpose of this chapter is to assist in troubleshooting the E1 Plus DeviceNet module.

ATTENTION

Servicing energized industrial control equipment can be hazardous. Electrical shock, burns, or unintentional actuation of controlled industrial equipment may cause death or serious injury. For safety of maintenance personnel, as well as other who may be exposed to electrical hazards associated with the maintenance activities, follow the local safety-related work practices (for example, the NFPS 70W, Part II, *Electrical Safety for Employee Workplaces*, in the United States) when working on or near energized equipment. maintenance personnel must be trained in the safety practices, procedures, and requirements that pertain to their respective job assignments. Do not work alone on energized equipment.

ATTENTION

Do not attempt to defeat or override fault circuits. The cause of a fault indication must be determined and corrected before attempting operation. Failure to correct a control system or mechanical malfunction may result in personal injury and/or equipment damage due to uncontrolled machine system operation.

DeviceNet Modes of Operation

The E1 Plus DeviceNet Module has four DeviceNet modes of operation: Power-up Reset Mode, Run Mode, Recoverable Error Mode, and Unrecoverable Error Mode.

Power-Up Reset Mode

During power-Up Reset Mode, the following occurs:

1. The *NETWORK STATUS* LED should flash green for approximately 1/4 second, then red for 1/4 second. If autobaud is enabled and the E1 Plus DeviceNet Module is not connected to an active network, this LED will not continue to flash.

IMPORTANT

The E1 Plus DeviceNet Module protection functions are still operational even without an established network connection.

2. Once the baud rate is determined, the E1 Plus DeviceNet Module performs a duplicate node address check to verify another node is not assigned to the same DeviceNet node address (MAC ID). If a duplicate node is detected on the network, the *NETWORK STATUS* LED turns solid red, and the E1 Plus DeviceNet Module enters the *Recoverable Error Mode*.

If the power-up or reset is successful, the overload relay will enter *Run Mode*.

Run Mode

In *Run Mode*, the E1 Plus DeviceNet Module will operate as a slave device to a master device. The *NETWORK STATUS* LED will blink green if there are no network connections established with a network master. When one or more connections are in the “established” state, the *NETWORK STATUS* LED will turn solid green. When one or more connections are in the “timed-out” state, the *NETWORK STATUS* LED will blink red. In the *Run Mode*, the E1 Plus DeviceNet Module will:

- Accept messages from a master on the DeviceNet network.
- Send response messages, COS messages, or CYCLIC messages to a master.

If a communication error is detected, the E1 Plus DeviceNet Module will either enter the *Recoverable Error* or *Unrecoverable Error Mode*.

Recoverable Error Mode

In *Recoverable Error Mode*, the E1 Plus DeviceNet Module's *NETWORK STATUS* LED turns solid red. The overload relays will respond to messages that are specified in offline node recovery message protocol.

Error Type	Description	LED State
Recoverable	Duplicate node address detected	Solid Red

Unrecoverable Error Mode

In *Unrecoverable Error Mode*, the E1 Plus DeviceNet Module's *NETWORK STATUS* LED turns solid red. The overload relay continues in this state as long as the device is powered.

Error Type	Description	LED State
Unrecoverable	Power-up initialization failure	Solid Red
	Incorrect baud rate	
	Fatal communication error (bus-off)	

DeviceNet Troubleshooting Procedures

The following table identifies possible causes and corrective actions when troubleshooting DeviceNet-related failures using the *NETWORK STATUS* LED.

Table 5.1 DeviceNet Troubleshooting Procedures

Color	State	Possible Cause	Corrective Action
None		<ol style="list-style-type: none"> 1. The E1 Plus DeviceNet Module is not receiving power at the DeviceNet connector. 2. The module may be "autobauding". 	Check DeviceNet power and cable connections and the power connection on the DeviceNet connector.
Green Red Off	Flashing (once)	<ol style="list-style-type: none"> 1. The E1 Plus DeviceNet Module is trying to determine the network baud rate. 2. Normal 	The Network Status LED flashes green, red, and off once during a normal power-up sequence.
Green	Flashing	E1 Plus DeviceNet Module is online but not allocated to a master.	Check DeviceNet master and its scan list for correct scanner configuration.
Green	Solid	Normal operating state, and the E1 Plus DeviceNet Module is allocated to a master.	No action required.
Red	Flashing	I/O connection timed-out.	Reset DeviceNet master device.
Red	Solid	<ol style="list-style-type: none"> 1. Diagnostics test failed on power-up/reset. Internal fault exists. 2. Duplicate DeviceNet node address exists (two DeviceNet nodes cannot have the same address). 3. Invalid baud rate (if autobaud is disabled). 4. A fatal communication error occurred such as "Bus Off". 	<ol style="list-style-type: none"> 1. Cycle power to the unit and network. If the fault still exists, replace unit. 2. Using the node commissioning tool, change the node address to a valid setting and reset the device. 3. This will only occur if Parameter 26, <i>AutoBaudEnable</i>, is set to "disabled". Set Parameter 26 to "enabled" and reset the E1 Plus DeviceNet Module (or) set the <i>Baud Rate</i> to the correct setting and reset the E1 Plus DeviceNet Module. 4. Check DeviceNet media for proper installation: <ul style="list-style-type: none"> • cable length according to baud rate • termination resistors • proper grounding

Input and Output Troubleshooting Procedures

ATTENTION



If the outputs are to be commanded via an explicit message, ensure that there can never be an established I/O connection that can actively control them, and that the explicit message connection has a non-zero expected packet rate (EPR) setting.

Table 5.2 Input and Output Troubleshooting Procedures

Failure Type	Failure Description	Corrective Action
Input 1, 2	Input 1 or 2 does not appear to recognize a contact closure	<ol style="list-style-type: none"> 1. Check the supply voltage on the DeviceNet connector. 2. If the applicable contact closed but the E1 Plus DeviceNet Module Input does not recognize the closure, check the continuity and wiring to the connected contact. 3. Check the IN 1 and 2 status LEDs. If the appropriate LED does not illuminate, measure the voltage across and current through the applicable input. Verify they are within the ratings of the E1 Plus DeviceNet Module (See Appendix A). 4. If the appropriate Input LED does illuminate, but the input status is not reported properly over the DeviceNet network, check the programmable controller ladder logic and I/O mapping.
Input 1, 2	Trip reset operation	Check the programming of Parameter 40, <i>IN1 Assignment</i> or Parameter 41, <i>IN2 Assignment</i> .

Table 5.2 Input and Output Troubleshooting Procedures (Continued)

Failure Type	Failure Description	Corrective Action
OUT A	Output A does not appear to turn on (close) when commanded to do so.	<ol style="list-style-type: none"> 1. Check the supply voltage on the DeviceNet connector. 2. Check the OUTA status LED. If the appropriate LED does not illuminate, check the programmable controller ladder logic and I/O mapping. 3. If the appropriate Output LED is illuminated, remove the control circuit power and check for continuity across the appropriate output terminals (13/14). If the continuity test indicates the output is open, replace the E1 Plus DeviceNet Module. Check the supply voltage against the ratings of the contactor and the relay output before installing a new unit. 4. Remove control circuit power and check the control circuit fuse and the control wiring to the E1 Plus DeviceNet Module output terminals. 5. Check the control circuit power supply. Verify the voltage is within the contactor and overload relay ratings. 6. Check the <i>DEVICE STATUS</i> and <i>TRIP STATUS</i> parameters. If a Protection Fault exists, refer to the <i>Trip and Warning</i> troubleshooting procedure. If a DeviceNet-related fault exists, refer to the <i>DeviceNet</i> troubleshooting procedure. 7. Check the OUTA Pr FltState, Pr FltValue, Dn FltState, Dn FltValue, Dn IdlState, and Dn IdlValue programmable parameters. The Pr FltState and Pr FltValue parameter supersede the Dn Flt or Dn Idle parameters.
OUT A	Output A does not appear to turn off (open) when commanded to do so.	<ol style="list-style-type: none"> 1. Check the OUTA status LED. If the appropriate LED remains illuminated, check the programmable controller ladder logic and I/O mapping. 2. If the appropriate Output LED is not illuminated, remove the control circuit power and check for continuity across the appropriate output terminals (13/14). If the continuity test indicates the output is closed, replace the E1 Plus DeviceNet Module. Check the supply voltage against ratings of the contactor and the relay output before installing a new unit. 3. Remove control circuit power and check the control circuit fuse and the control wiring to the E1 Plus DeviceNet Module output terminals. 4. Check the OUTA Pr FltState, Pr FltValue, Dn FltState, Dn FltValue, Dn IdlState, and Dn IdlValue programmable parameters. Then check the <i>DEVICE STATUS</i> and <i>TRIP STATUS</i> parameters. If a Protection Fault exists, refer to the <i>TRIP STATUS</i> parameters. If a Protection fault exists, refer to the <i>Trip and Warning</i> troubleshooting procedure. If a DeviceNet-related fault exists, refer to the <i>DeviceNet</i> troubleshooting procedure.
OUT A	The contactor connected to Output A appears to "chatter"	<ol style="list-style-type: none"> 1. Verify the OUT A LED remains in the appropriate On or Off state. If the LED is flickering, check the programmable controller's ladder logic program. 2. Check the control circuit supply voltage. Verify it is within the ratings of the contactor coil and the overload relay's outputs. 3. Remove the control circuit power. Verify all control wiring is properly secured.

Trip and Warning Troubleshooting Procedures

The following table lists the possible causes for each trip type and the recommended action to take.

Table 5.3 Trip/Warn LED Troubleshooting Procedures

Overload	<ol style="list-style-type: none"> 1. Motor overloaded 2. Improper setting 	<ol style="list-style-type: none"> 1. Check and correct source of overload (load, mechanical transmission components, motor bearings). 2. Set FLA dial and trip class to match the motor and application requirements.
Phase Loss	<ol style="list-style-type: none"> 1. Missing supply phase 2. Poor electrical connection 3. Contactor operation 4. Improper device type 	<ol style="list-style-type: none"> 1. Check for open line (i.e. blown fuse). 2. Check all power terminations from the branch circuit-protecting device down to the motor for proper tightness. Ensure that the overload connection to the contactor is secure. 3. Inspect contactor for proper operation. 4. Bulletin 193S or 592S are required for single-phase applications.
Jam	<ol style="list-style-type: none"> 1. Motor current has exceeded the programmed jam level 2. Improper parameter settings 	<ol style="list-style-type: none"> 1. Check for the source of the jam (i.e. excessive load or mechanical transmission component failure). 2. Parameter 20, <i>Jam Trip Level</i>, is set too low for the application. Check to ensure that the FLA dial is set correctly.

Specifications

Terminal Ratings:		
Terminal Screw		M3
Wire Cross Section		See wiring diagram section
Torque		0.5...0.6 N•m (4.4...5.3 lb.-in)
Degree of Protection		IP20
Power Supply Ratings:		
Terminals		DeviceNet Connector: V+(Red), V-(Black)
Rated Supply Voltage	U_s	24V DC
Rated Operating Range	U_e	11...25V DC
Rated Supply Current	I_e	0.23 A at 11V DC 0.10 A at 25V DC
Maximum Surge Current at Power-Up		2.5 A
Maximum Power Consumption		2.5 W
Maximum Power Interruption Time @11V DC @25V DC		0.2 ms 1.5 ms
Output Relay Ratings:		
Terminals OUT A:		13/14
Type of Contacts		Form A SPST - NO
Rated Thermal Current	I_{the}	5 A
Rated Insulation Voltage	U_i	300V AC
Rated Operating Voltage	U_e	240V AC
Rated Operating Current	I_e	3 A (at 120V AC), 1.5 A (at 240V AC) 0.25 A (at 110V DC), 0.1 A (at 220V DC)
Minimum Operating Current		10 mA at 5V DC
Rating Designation		B300
Utilization Category		AC-15
Resistive Load Rating (p.f.=1.0)		5 A, 250V DC 5 A, 30V DC
Inductive Load Rating (p.f.=0.4), (L/R=7 ms)		2 A, 250V AC 2 A, 30V DC
Short Circuit Current Rating		1,000 A

Recommended Control Circuit Fuse	KTK-R-6 (6 A, 600V)
Rated Number of Operations Out A: W/100-C-09...100-C43 W/100-C-60...100-C85 W/NEMA Size 0...2 W/NEMA Size 3	5,000,000 2,500,000 1,000,000 300,000
Input Ratings:	
Terminals IN 1: IN 2: SSV (Sensor Supply Voltage)	1 2 3
Supply Voltage (provided by module)	24V DC±15%
Type of Inputs	Current Sinking
ON-State Voltage	15V DC
On-State Current (turn-on)	2 mA
Steady State Current	5 mA
Off-State Voltage	5V DC
Off-State Current	0.5 mA
Transition Voltage	5...15V DC
Transition Current	0.5...2.0 mA
Environmental Ratings:	
Ambient Temperature <i>Tamb</i> Storage Operating (Open) (Enclosed)	-40...+85°C (-40...+185°F) -20...+60°C (-4...+140°F) -20...+40°C (-4...+104°F)
Humidity Operating Damp Heat - Steady State Damp Heat - Cyclic	5...95% non-condensing per IEC 68-2-3 per IEC 68-2-30
Cooling Method	Natural Convection
Vibration (per IEC 68-2-6)	3 G
Shock (per IEC 68-2-27)	30 G
Maximum Altitude	2000 m
Pollution Environment	Pollution Degree 2
Terminal Marking	EN 50012
Degree of Protection	IP20
Electromagnetic Compatibility	
Electrostatic Discharge Immunity Test Level Performance Criteria	8 kV Air Discharge 4 kV Contact Discharge 1①↻

RF Immunity	Test Level	10V/m
	Performance Criteria	1①🚧
Electrical Fast Transient/Burst Immunity	Test Level	2 kV (Power) 1 kV (control)
	Performance Criteria	1①🚧
Surge Immunity	Test Level	2 kV L-E 1 kV L-L
	Performance Criteria	1①🚧
Radiated Emissions		Class A
Conducted Emissions		Not tested

① Performance Criteria 1 requires the DUT (device under test) not to experience degradation or loss of performance.

🚧 Environment 2 - Heavy Industrial.

WARNING

This is a class A product. In domestic environment, this product may cause radio interference, in which case the user may be required to take adequate measures.

DeviceNet Communications:

Baud Rate	125 k, 250 k, 500 k
Auto-Baud Rate identification	Yes
Group 2 - Master-Slave Connection Set	Yes
Polled I/O Messaging	Yes
Change of State Messaging	Yes
Cyclic Messaging	Yes
Explicit Messaging	Yes
Full Parameter Object Support	Yes
Group 4 - Off-line Node Recovery Messaging	Yes
Configuration Consistency Value	Yes
Unconnected Message Manager (UCMM)	Yes

Jam Protection:

Trip Level	150...600% FLA
Trip Delay	0.1...25.0 sec.
Inhibit	0...250 sec.

Standards

UL 508
CSA 22.2, No. 14
EN 60947-4-1

DeviceNet Information

Electronic Data Sheets

Electronic Data Sheet (EDS) files are specially formatted ASCII files that provide all of the information necessary for a configuration tool (e.g., RSNetWorx for DeviceNet) to access and alter the parameters of a device. The EDS file contains all the parameter information of a device: number of parameters, groupings, parameter name, min, max, and default values, units, data format and scaling. The EDS file for the E1 Plus DeviceNet Module is available from the Internet at www.ab.com/networks/eds/index/html. It can also be built automatically by some configuration tools since all of the information necessary for an EDS file may be extracted from the E1 Plus DeviceNet Module.

DeviceNet Objects

The following object classes are supported.

Table B.1 DeviceNet object Classes

Class	Object
0x0001	Identity
0x0002	Message Router
0x0003	DeviceNet
0x0004	Assembly
0x0005	Connection
0x0008	Discrete Input Point
0x0009	Discrete Output Point
0x000F	Parameter
0x0010	Parameter Group
0x0029	Control Supervisor
0x002B	Acknowledge Handler
0x002C	Overload
0x00B4	DN Interface

Identity Object — CLASS CODE 0x0001

The following class attributes are supported for the Identity Object:

Table B.2 Identity Object Class Attributes

Attribute ID	Access Rule	Name	Data Type	Value
1	Get	Revision	UINT	1

Two instances (instance 1-2) of the Identity Object are supported. The following table shows what each instance will represent, and what the revision attribute reports:

Table B.3 Identity Object Instances

Inst.		Revision Attribute
1	Operating System Flash	The firmware rev of the OS stored in flash memory.
2	Boot Code Flash	The firmware rev of the boot code stored in flash memory.

Identity Object instances contain the following instance attributes:

Table B.4 Identity Object Instance Attributes

Attribute ID	Access Rule	Name	Data Type	Value
1	Get	Vendor	UINT	Programmable via test object
2	Get	Device Type	UINT	3
3	Get	Product Code	UINT	200 or 201
4	Get	Revision Major Revision Minor Revision	Structure of USINT USINT	1 1
5	Get	Status	WORD	Bit 0: 0=Not owned; 1=Owned by master Bit 2: 0=Factory Defaulted; 1= Configured Bit 8: Minor Recoverable fault Bit 9: Minor Unrecoverable fault Bit 10: Major Recoverable fault Bit 11: Major Unrecoverable fault
6	Get	Serial Number	UDINT	unique number for each device
7	Get	Product Name String Length ASCII String	Structure of: USINT STRING	
8	Get	State	USINT	Returns the value "3=Operational"
9	Get	Configuration Consistency Value	UINT	Unique value depending on output of the parameter checksum algorithm.
10	Get/Set	Heartbeat Interval	USINT	In seconds. Default=0.

The following common services are implemented for the Identity Object:

Table B.5 Identity Object Common Services

Service Code	Implemented for:		Service Name
	Class	Instance	
0x0E	No	Yes	Get_Attribute_Single
0x10	No	Yes	Set_Attribute_Single
0x05	No	Yes	Reset

Message Router — CLASS CODE 0x0002

No class or instance attributes are supported. The message router object exists only to rout explicit messages to other objects.

DeviceNet Object — CLASS CODE 0x0003

The following class attributes are supported for the DeviceNet Object:

Table B.6 DeviceNet object Class Attributes

Attribute ID	Access Rule	Name	Data Type	Value
1	Get	Revision	UINT	2

A single instance (instance 1) of the DeviceNet Object is supported. The following instance attributes are supported.

Table B.7 DeviceNet Object Instance Attributes

Attribute ID	Access Rule	Name	Data Type	Value
1	Get/Set	Node Address	USINT	0...63
2	Get/Set	Baud Rate	USINT	0=125k 1=250k 2=500k
5	Get	Allocation Info Allocation Choice Master Node Addr	Structure of: BYTE USINT	Allocation_byte** 0...63=address 255=unallocated

**Allocation_byte

- Bit 0 Explicit messaging
- Bit 1 Polled I/O
- Bit 4 COS I/O
- Bit 5 Cyclic I/O
- Bit 6 Acknowledge Suppression

The following services are implemented for the DeviceNet Object:

Table B.8 DeviceNet Object Common Services

Service Code	Implemented for:		Service Name
	Class	Instance	
0x0E	Yes	Yes	Get_Attribute_Single
0x10	No	Yes	Set_Attribute_Single
0x4B	No	Yes	Allocate_Master/Slave_Connection_Set
0x4C	No	Yes	Release_Master/Slave_Conncetion_Set

Assembly Object — CLASS CODE 0x0004

The following class attributes are supported for the Assembly Object:

Table B.9 Assembly Object Class Attributes

Attribute ID	Access Rule	Name	Data Type	Value
2	Get	Max Instance	UINT	TBD

Output Assemblies

The following output assembly instances are implemented:

Table B.10 Instance 2 — Basic Overload Output Assembly from ODVA Profile

Byte	Bit 7	Bit 6	Bit 5	Bit 4	Bit 3	Bit 2	Bit 1	Bit 0
0						Trip Reset		

Table B.11 Instance 101 — Similar to Basic Contactor Output Assembly in ODVA Contactor Profile

Byte	Bit 7	Bit 6	Bit 5	Bit 4	Bit 3	Bit 2	Bit 1	Bit 0
0								Output A

Table B.12 Instance 103 — Similar to Basic Motor Starter Output Assembly in ODVA Starter Profile

Byte	Bit 7	Bit 6	Bit 5	Bit 4	Bit 3	Bit 2	Bit 1	Bit 0
0						Trip Reset		Output A

*Input Assemblies***Table B.13 Instance 50 — Basic Overload Input Assembly from ODVA Overload Profile**

Byte	Bit 7	Bit 6	Bit 5	Bit 4	Bit 3	Bit 2	Bit 1	Bit 0
0								Tripped

Table B.14 Instance 51 — Extended Overload Input Assembly from ODVA Overload Profile

Byte	Bit 7	Bit 6	Bit 5	Bit 4	Bit 3	Bit 2	Bit 1	Bit 0
0							Warning	Tripped

Table B.15 Instance 100 — Parameter Based Input Assembly

Word	Byte	Bit 7	Bit 6	Bit 5	Bit 4	Bit 3	Bit 2	Bit 1	Bit 0
0	0	Value of the parameter pointed to by parameter #30 (low byte)							
	1	Value of the parameter pointed to by parameter #30 (high byte)							
1	2	Value of the parameter pointed to by parameter #31 (low byte)							
	3	Value of the parameter pointed to by parameter #31 (high byte)							
2	4	Value of the parameter pointed to by parameter #32 (low byte)							
	5	Value of the parameter pointed to by parameter #32 (high byte)							
3	6	Value of the parameter pointed to by parameter #33 (low byte)							
	7	Value of the parameter pointed to by parameter #33 (high byte)							

Table B.16 Instance 106 — Motor Starter Input Assembly

Byte	Bit 7	Bit 6	Bit 5	Bit 4	Bit 3	Bit 2	Bit 1	Bit 0
0	Motor Current		Input 2	Input 1		Out A Stat	Warning	Tripped

Table B.17 Instance 110 — Extended Motor Starter Input Assembly

Byte	Bit 7	Bit 6	Bit 5	Bit 4	Bit 3	Bit 2	Bit 1	Bit 0
0	Motor Current		Input 2	Input 1		Out A Stat	Warning	Tripped
1	Unused							
2	Average %FLA							
3								
4	%Therm Utilized							
5								

The following services are implemented for the Assembly Object:

Table B.18 DeviceNet Object Common Services

Service Code	Implemented for:		Service Name
	Class	Instance	
0x0E	Yes	Yes	Get_Attribute_Single
0x10	No	Yes	Set_Attribute_Single
0x18	No	Yes	Get_Member

Connection Object — CLASS CODE 0x0005

No class attributes are supported for the Connection Object. Multiple instances of the Connection Object are supported, instances 2 and 4 from the group 2 predefined master/slave connection set, and instances 5-7 are available explicit UCMM connections.

Instance 2 is the Polled I/O Message Connection. The following instance 2 attributes are supported:

Table B.19 Connection Object Instance 2 Attributes

Attribute ID	Access Rule	Name	Data Type	Value
1	Get	State	USINT	0=Nonexistant 1= Configuring 3=Established 4=Timed out
2	Get	Instance Type	USINT	1=I/O Connection
3	Get	Transport Class Trigger	USINT	0x82: Server, Transport Class 2 (If alloc_choice!=polled and ack suppression is enabled, the value = 0x80)
4	Get	Produced Connection ID	UINT	01111xxxxx xxxxxx=node address
5	Get	Consumed Connection ID	UINT	10xxxxxx101 xxxxxx=node address
6	Get	Initial Comm Characteristics	USINT	0x21
7	Get	Produced Connection Size	UINT	0...8
8	Get	Consumed Connection Size	UINT	0...8
9	Get/Set	Expected Packet Rate	UINT	in milliseconds
12	Get/Set	Watchdog Action	USINT	0=Transition to timed out 1=Auto deleted 2=Auto reset
13	Get	Produced Connection Path Length	UINT	8
14	Get/Set	Produced Connection Path		21 04 00 25 (assy inst) 00 30 03
15	Get	Consumed Connection Path Length	UINT	8
16	Get/Set	Consumed Connection Path		21 04 00 25 (assy inst) 00 30 03

Instance 4 is the Predefined Group 2 Connection Set Change of State/Cyclic I/O Message Connection. The following instance 4 attributes are supported:

Table B.20 Connection Object Instance 4 Attributes

Attribute ID	Access Rule	Name	Data Type	Value
1	Get	State	USINT	0=Nonexistent 1=Configuring 3=Established 4=Timed out
2	Get	Instance Type	USINT	1=I/O Connection
3	Get	Transport Class Trigger	USINT	0x00 (Cyclic, unacknowledged) 0x03 (Cyclic, acknowledged) 0x10 (COS, unacknowledged) 0x13 (COS, acknowledged)
4	Get	Produced Connection ID	UINT	01101xxxxx xxxxxx=node address
5	Get	Consumed Connection ID	UINT	10xxxxxx101 xxxxxx=node address
6	Get	Initial Comm Characteristics	USINT	0x02 (acknowledged) 0x0F (unacknowledged)
7	Get	Produced Connection Size	UINT	0...8
8	Get	Consumed Connection Size	UINT	0...8
9	Get/Set	Expected Packet Rate	UINT	in milliseconds
12	Get	Watchdog Action	USINT	0=Transition to timed out 1=Auto delete 2=Auto reset
13	Get	Produced Connection Path Length	UINT	8
14	Get	Produced Connection Path		21 04 00 25 (assy inst) 00 30 03
15	Get	Consumed Connection Path Length	UINT	8
16	Get/Set	Consumed Connection Path		21 04 00 25 (assy inst) 00 30 03

Instances 5...7 are available group 3 Explicit Message Connections that are allocated through the UCMM. The following attributes are supported:

Table B.21 Connection Object Instances 5...7 Attributes

Attribute ID	Access Rule	Name	Data Type	Value
1	Get	State	USINT	0=Nonexistent 1=Configuring 3=Established 4=Timed out
2	Get	Instance Type	USINT	0=Explicit Message
3	Get	Transport Class Trigger	USINT	0x83: Server, Transport Class 3
4	Get	Produced Connection ID	UINT	Depends on message group and Message ID
5	Get	Consumed Connection ID	UINT	Depends on message group and Message ID
6	Get	Initial Comm Characteristics	USINT	0x33 (Group 3)
7	Get	Produced Connection Size	UINT	0
8	Get	Consumed Connection Size	UINT	
9	Get/Set	Expected Packet Rate	UINT	in milliseconds
12	Get	Watchdog Action	USINT	01=auto delete 03=deferred delete
13	Get	Produced Connection Path Length	UINT	0
14	Get	Produced Connection Path		Empty
15	Get	Consumed Connection Path Length	UINT	0
16	Get	Consumed Connection Path		Empty

The following are implemented for the Connection Object:

Table B.22 Connection Object Common Services

Service Code	Implemented for:		Service Name
	Class	Instance	
0x05	No	Yes	Reset
0x0E	No	Yes	Get_Attribute_Single
0x10	No	Yes	Set_Attribute_Single

Discrete Input Point Object — CLASS CODE 0x0008

The following class attributes are supported for the Discrete Input Point Object:

Table B.23 Discrete Input Point Object Class Attributes

Attribute ID	Access Rule	Name	Data Type	Value
1	Get	Revision	UINT	2
2	Get	Max Instance	UINT	2

Two instances of the Discrete Input Point Object are supported as follows:

Table B.24 Discrete Input Point Object Instances

Attribute ID	Access Rule	Name	Data Type	Value
3	Get	Value	BOOL	0=OFF 1=ON

The following common services are implemented for the Discrete Input Point Object:

Table B.25 Discrete Input Object Common Services

Service Code	Implemented for:		Service Name
	Class	Instance	
0x0E	Yes	Yes	Get_Attribute_Single
0x10	No	Yes	Set_Attribute_Single

Discrete Output Point Object — CLASS CODE 0x0009

The following class attributes are supported for the Discrete Output point Object:

Table B.26 Discrete Output Point Object Class Attributes

Attribute ID	Access Rule	Name	Data Type	Value
1	Get	Revision	UINT	1
2	Get	Max Instance	UINT	1

A single instance is implemented and contains the following attributes:

Table B.27 Discrete Output Point Object Instance Attributes

Attribute ID	Access Rule	Name	Data Type	Value
3	Get	Value	BOOL	0=OFF 1=ON
5	Get/Set	Fault Action	BOOL	0=Fault Value Attribute 1=Hold Last State
6	Get/Set	Fault Value	BOOL	0=Off 1=ON
7	Get/Set	Idle Action	BOOL	0=Fault Value Attribute 1=Hold Last State
8	Get/Set	Idle Value	BOOL	0=OFF 1=ON
113	Get/Set	Pr Fault Action	BOOL	0=Pr Fault Value Attribute 1=Ignore
114	Get/Set	Pr Fault Value	BOOL	0=Off 1=On

The following common services are implemented for the Discrete Output Point Object:

Table B.28 Discrete Output Object Common Services

Service Code	Implemented for:		Service Name
	Class	Instance	
0x0E	No	Yes	Get_Attribute_Single
0x10	No	Yes	Set_Attribute_Single

Parameter Object —CLASS CODE 0x000F

The following class attributes are supported for the Parameter Object:

Table B.29 Parameter Object Class Attributes

Attribute ID	Access Rule	Name	Data Type	Value
1	Get	Revision	UINT	1
2	Get	Max Instance	UINT	38
8	Get	Parameter Class Descriptor	WORD	0x03
9	Get	Configuration Assembly Instance	UINT	0
10	Get	Native Language	UINT	1= English

The following instance attributes are implemented for all parameter attributes:

Table B.30 Parameter Object Instance Attributes

Attribute ID	Access Rule	Name	Data Type	Value
1	Get/Set	Value	Specified in Descriptor	
2	Get	Link Path Size	USINT	08
3	Get	Link Path	Array of BYTE EPATH	Path to specified object attribute.
4	Get	Descriptor	WORD	Parameter Dependent
5	Get	Data Type	EPATH	Parameter Dependent
6	Get	Data Size	USINT	Parameter Dependent
7	Get	Parameter Name String	SHORT_STRING	Parameter Dependent
8	Get	Units String	SHORT_STRING	Parameter Dependent
9	Get	Help String	SHORT_STRING	Parameter Dependent
10	Get	Minimum Value	Specified in Descriptor	Parameter Dependent
11	Get	Maximum Value	Specified in Descriptor	Parameter Dependent
12	Get	Default Value	Specified in Descriptor	Parameter Dependent
13	Get	Scaling Multiplier	UINT	01
14	Get	Scaling Divisor	UINT	01
15	Get	Scaling Base	UINT	01
16	Get	Scaling Offset	INT	00
17	Get	Multiplier Link	UINT	0
18	Get	Divisor Link	UINT	0
19	Get	Base Link	UINT	0
20	Get	Offset Link	UINT	0
21	Get	Decimal Precision	USINT	Parameter Dependent

The following common services are implemented for the Parameter Object:

Table B.31 Parameter Object Common Services

Service Code	Implemented for:		Service Name
	Class	Instance	
0x0E	Yes	Yes	Get_Attribute_Single
0x10	No	Yes	Set_Attribute_Single

Parameter Group Object — CLASS CODE 0x0010

The following class attributes are supported for the Parameter Object:

Table B.32 Parameter Group Object Class Attributes

Attribute ID	Access Rule	Name	Data Type	Value
1	Get	Revision	UINT	1
2	Get	Max Instance	UINT	5
8	Get	Native Language	USINT	1= English

The following parameter group objects are supported:

- Instance 1 = Monitor Parameters
- Instance 2 = Reset/Lock Parameters
- Instance 3 = Advanced Setup Parameters
- Instance 4 = DeviceNet Setup Parameters
- Instance 5 = I/O Parameters

The following instance attributes are supported for all parameter group instances:

Table B.33 Parameter Group Object Instance Attributes

Attribute ID	Access Rule	Name	Data Type	Value
1	Get	Group Name String	SHORT_STRING	
2	Get	Number of Members	UINT	
3	Get	1st Parameter	UINT	
4	Get	2nd parameter	UINT	
n	Get	Nth Parameter	UINT	

The following common services are implemented for the Parameter Group Object:

Table B.34 Parameter Group Object Common Services

Service Code	Implemented for:		Service Name
	Class	Instance	
0x0E	Yes	Yes	Get_Attribute_Single

Control Supervisor Object — CLASS CODE 0x0029

No class attributes are supported for the Control Supervisor Object. A single instance (instance 1) of the Control Supervisor Object is supported. The following instance attributes are supported.

Table B.35 Control Supervisor Object Instance Attributes

Attribute ID	Access Rule	Name	Data Type	Value
10	Get	Tripped	BOOL	0=No Fault present 1= Fault Latched
11	Get	Warning	BOOL	0=No Warning Present 1=Warning present (not latched)
12	Get/Set	Fault Reset	BOOL	1...>1=Trip Reset; otherwise no action
13	Get	Trip Code	UINT	ODVA TRip Code—In trip state indicates cause of trip; if not tripped, indicates cause of last trip.
14	Get	Warning Code	UINT	ODVA Warning Code—In warning state indicates cause of warning; if no warning, indicates cause of last warning.
100	Get	Trip Status	WORD	Bit 0=Overload Bit 1=Phase Loss Bit 2=Jam Bit 3=Not Used Bit 4=Not Used Blt 5=Not Used Bit 6=Not Used Bit 7=Not Used
101	Get	Warning Status	WORD	Bit 0=Overload Bit 1=Not Used Bit 2=Jam Bit 3=Underload Bit 4=Not Used Blt 5=Comm Fault Bit 6=Comm Idle Bit 7=EEPROM
102	Get	Trip Lob 0	WORD	Last trip condition. Bit definitions of the value are the same as attribute 114.
103	Get	Trip Log 1	WORD	Last trip condition. Bit definitions of the value are the same as attribute 114.

Table B.35 Control Supervisor Object Instance Attributes

Attribute ID	Access Rule	Name	Data Type	Value
104	Get	Trip Log 2	WORD	Last trip condition. Bit definitions of the value are the same as attribute 114.
105	GEt	Trip Log 3	WORD	Last trip condition. Bit definitions of the value are the same as attribute 114.
106	Get	Trip Log 4	WORD	Last trip condition. Bit definitions of the value are the same as attribute 114.
107	Get	Device Status	WORD	Bit 0=Trip Bit 1=Warning Bit 2=OutputA Bit 3=Input 1 Bit 4=Input 2 Bit 5=Motor Current
108	Get/Set	Trip Enable	WORD	Bit 0=Not Used Bit 1=Not Used Bit 2=Jam Bit 3=Not Used Bit 4=Not Used Bit 5=Not Used Bit 6=Not Used Bit 7=Not Used
109	Get/Set	Warning Enable	WORD	Bit 0=Overload Bit 1=Not Used Bit 2=Jam Bit 3=Underload Bit 4=Not Used Bit 5=Comm Fault Bit 6=Comm Idle Bit 7=Not Used
110	Get/Set	Reset Mode	BOOL	0=Manual 1=Automatic
111	Get/Set	IN1 Assignment	USINT	0=Normal 1=Trip Rest 2=OL Contact
112	Get/Set	IN2 Assignment	USINT	0=Normal 1=Trip Reset 2=OL Contact

The following common services are implemented for the Control Supervisor Object:

Table B.36 Control Supervisor Object Common Services

Service Code	Implemented for:		Service Name
	Class	Instance	
0x0E	No	Yes	Get_Attribute_Single
0x10	No	Yes	Set_Attribute_Single

Acknowledge Handler Object — CLASS CODE 0x002B

No class attributes are supported for the Acknowledge Handler Object. A single instance (instance 1) of the Acknowledge Handler Object is supported. The following instance attributes are supported:

Table B.37 Acknowledge Handler Object Instance Attributes

Attribute ID	Access Rule	Name	Data Type	Value
1	Get/Set	Acknowledge Timer	UINT	milliseconds
2	Get	Retry Limit	USINT	1
3	Get	COS Producing Connection Instance	UINT	4

The following common services are implemented for the Acknowledge Handler Object:

Table B.38 Acknowledge Handler Object Common Services

Service Code	Implemented for:		Service Name
	Class	Instance	
0x0E	No	Yes	Get_Attribute_Single
0x10	No	Yes	Set_Attribute_Single

6.12. Overload Object — CLASS CODE 0x002C

No class attributes are supported for the Overload Object. A single instance (instance 1) of the Overload Object is supported:

Table B.39 Overload Object Instance Attributes

Attribute ID	Access Rule	Name	Data Type	Value
7	Get	% Thermal Utilized	USINT	xxx% FLA
108	Get	Average %FLA	UINT	0...1000 %FLA
109	Get	% Thermal Utilized	USINT	0...100%
127	Get/Set	Single/Three Phase	BOOL	0=Single Phase 1=Three Phase
132	Get/Set	OL Warn Level	USINT	0...100% TCU
141	Get/Set	Jam Inhibit Time	USINT	0...250 Sec.
142	Get/Set	Jam Trip Delay	USINT	0.5...25.0 Sec.
143	Get/Set	Jam Trip Level	UINT	150...600 %FLA
144	Get/Set	Jam Warn Level	UINT	100...600 %FLA
145	Get/Set	UL Inhibit Time	USINT	0...250 Sec.
148	Get/Set	UL Warn Level	USINT	30...100 %FLA

The following common services are implemented for the Overload Object:

Table B.40 Overload Object Common Services

Service Code	Implemented for:		Service Name
	Class	Instance	
0x0E	No	Yes	Get_Attribute_Single
0x10	No	Yes	Set_Attribute_Single

DeviceNet Interface Object — CLASS CODE 0x00B4

The following class attributes are supported for the DeviceNet Interface Object:

Table B.41 DeviceNet Interface Object Class Attributes

Attribute ID	Access Rule	Name	Data Type	Value
1	Get	Revision	UINT	3

A single instance (instance 1) of the DeviceNet Interface Object is supported:

Table B.42 Acknowledge Handler Object Instance Attributes

Attribute ID	Access Rule	Name	Data Type	Min/Max	Default	Description
5	Get/Set	Nonvolatile MAC ID	USINT	0...63	63	
6	Get/Set	Nonvolatile Baud	USINT	0...2	0	
7	Get/Set	Assy Word 0 Param	USINT	0...41	1	
8	Get/Set	Assy Word 1 Param	USINT	0...41	2	
9	Get/Set	Assy Word 2 Param	USINT	0...41	3	
10	Get/Set	Assy Word 3 Param	USINT	0...41	4	
12	Get	Firmware Rev	UINT	0...65.535	1.001	Firmware rev in EDS parameter format
15	Get/Set	Autobaud Enable	BOOL	0...1	1	1=Enabled 0=Disabled
16	Get/Set	Consumed Assy	USINT	0...103	103	Output Assembly Instance
17	Get/Set	Produced Assy	USINT	0...110	110	Input Assembly Instance
18	Get/Set	Param Lock	BOOL	0...1	0	0=Unlocked 1=Locked
19	Get/Set	Set To Defaults	BOOL	0...1	0	0=No action 1=Reset

The following common services are implemented for the DeviceNet Interface Object.

Table B.43 DeviceNet Interface Object Common Services

Service Code	Implemented for:		Service Name
	Class	Instance	
0x0E	No	Yes	Get_Attribute_Single
0x10	No	Yes	Set_Attribute_Single

ODVA Fault Codes

The following ODVA fault codes are returned by the Control Supervisor Object instance attribute 13 “TripCode”.

Table B.44 ODVA Fault Codes

Trip Code	Description
21	Thermal Overload
28	Jam
29	Underload
60	Hardware Fault
62	Memory Fault
102	Communications Fault
103	Communications Idle

Rockwell Automation Support

Rockwell Automation provides technical information on the web to assist you in using its products. At <http://support.rockwellautomation.com>, you can find technical manuals, a knowledge base of FAQs, technical and application notes, sample code and links to software service packs, and a MySupport feature that you can customize to make the best use of these tools.

For an additional level of technical phone support for installation, configuration and troubleshooting, we offer TechConnect Support programs. For more information, contact your local distributor or Rockwell Automation representative, or visit <http://support.rockwellautomation.com>.

Installation Assistance

If you experience a problem with a hardware module within the first 24 hours of installation, please review the information that's contained in this manual. You can also contact a special Customer Support number for initial help in getting your module up and running:

United States	1.440.646.3223 Monday – Friday, 8am – 5pm EST
Outside United States	Please contact your local Rockwell Automation representative for any technical support issues.

New Product Satisfaction Return

Rockwell tests all of its products to ensure that they are fully operational when shipped from the manufacturing facility. However, if your product is not functioning and needs to be returned:

United States	Contact your distributor. You must provide a Customer Support case number (see phone number above to obtain one) to your distributor in order to complete the return process.
Outside United States	Please contact your local Rockwell Automation representative for return procedure.

www.rockwellautomation.com

Power, Control and Information Solutions Headquarters

Americas: Rockwell Automation, 1201 South Second Street, Milwaukee, WI 53204-2496 USA, Tel: (1) 414.382.2000, Fax: (1) 414.382.4444

Europe/Middle East/Africa: Rockwell Automation, Vorstlaan/Boulevard du Souverain 36, 1170 Brussels, Belgium, Tel: (32) 2 663 0600, Fax: (32) 2 663 0640

Asia Pacific: Rockwell Automation, Level 14, Core F, Cyberport 3, 100 Cyberport Road, Hong Kong, Tel: (852) 2887 4788, Fax: (852) 2508 1846