

# **MP-Series Stainless Steel Servo Motor**

Catalog Numbers MPS-A330, MPS-A4540, MPS-B330, MPS-B4540, MPS-B560

<b>Topic</b>	<b>Page</b>
Important User Information	2
Before You Begin	4
Installing the Motor	9
Motor Mounting Requirements	9
Power Cable Shielding	9
Motor Connections	16
Dimensions	13
Removing and Installing a Shaft Key	19
Slinger and Shaft Seal Removal and Installation	20
Motor Cables and Accessory Kits	24
Specifications	23
Additional Resources	26

## **About the MP-Series Stainless Steel Servo Motor**

The MP-Series stainless-steel motors are designed to meet the unique needs of hygienic manufacturing environments such as food, beverage, brewing, dairy, health and beauty, and pharmaceutical products.

MP-Series stainless-steel motors are available in frame sizes up to 165 mm.

## Important User Information

Solid state equipment has operational characteristics differing from those of electromechanical equipment. Safety Guidelines for the Application, Installation and Maintenance of Solid State Controls (Publication SGI-1.1 available from your local Rockwell Automation sales office or online at <http://literature.rockwellautomation.com>) describes some important differences between solid state equipment and hard-wired electromechanical devices. Because of this difference, and also because of the wide variety of uses for solid state equipment, all persons responsible for applying this equipment must satisfy themselves that each intended application of this equipment is acceptable.





In no event will Rockwell Automation, Inc. be responsible or liable for indirect or consequential damages resulting from the use or application of this equipment.

The examples and diagrams in this manual are included solely for illustrative purposes. Because of the many variables and requirements associated with any particular installation, Rockwell Automation, Inc. cannot assume responsibility or liability for actual use based on the examples and diagrams.

No patent liability is assumed by Rockwell Automation, Inc. with respect to use of information, circuits, equipment, or software described in this manual.

Reproduction of the contents of this manual, in whole or in part, without written permission of Rockwell Automation, Inc., is prohibited.

Throughout this manual, when necessary, we use notes to make you aware of safety considerations.

<p><b>WARNING</b></p> 	Identifies information about practices or circumstances that can cause an explosion in a hazardous environment, which may lead to personal injury or death, property damage, or economic loss.
<p><b>IMPORTANT</b></p>	Identifies information that is critical for successful application and understanding of the product.
<p><b>ATTENTION</b></p> 	Identifies information about practices or circumstances that can lead to personal injury or death, property damage, or economic loss. Attentions help you identify a hazard, avoid a hazard and recognize the consequences.
<p><b>SHOCK HAZARD</b></p> 	Labels may be on or inside the equipment, for example, a drive or motor, to alert people that dangerous voltage may be present.
<p><b>BURN HAZARD</b></p> 	Labels may be on or inside the equipment, for example, a drive or motor, to alert people that surfaces may reach dangerous temperatures.

## Catalog Number Explanation

### MP S - B 3 30 P - M J 5 2 D A

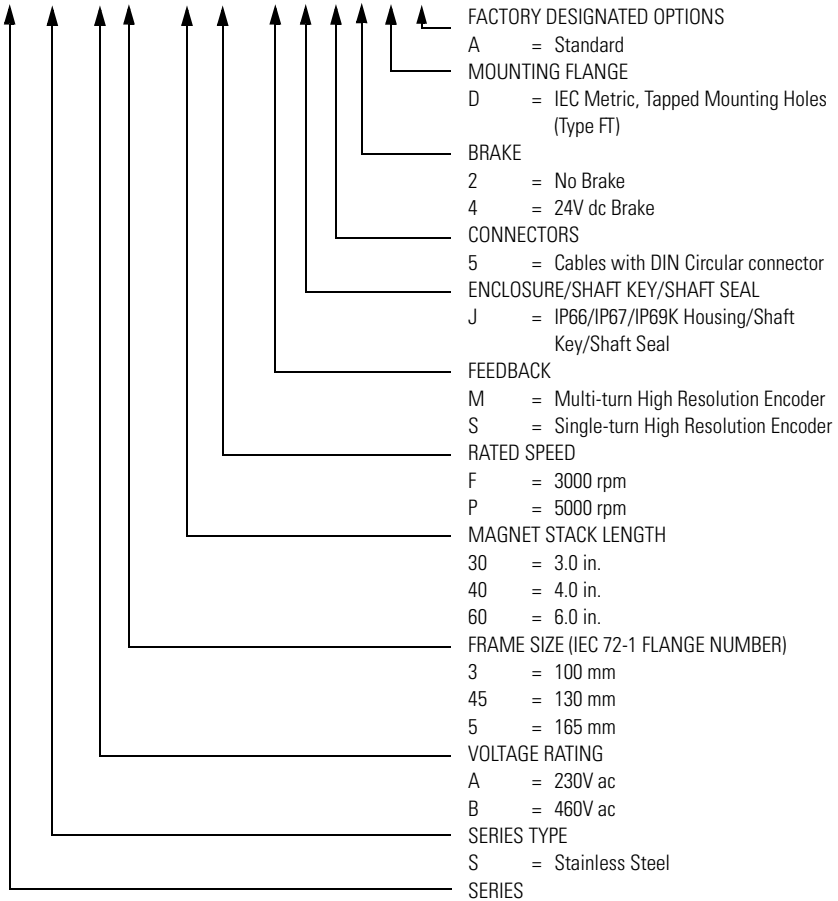

## Before You Begin

Before unpacking the product, inspect the shipping carton for damage. If damage is visible, immediately contact the shipper and request assistance. Otherwise, proceed with unpacking.

Remove the motor carefully from its shipping container, and visually inspect the motor for any damage. Carefully examine the motor frame, front output shaft, and mounting pilot for any defects.

Keep the original packing material in case you need to return the product for repair or transport it to another location. Use both the inner and outer packing cartons to verify adequate protection for a unit returned for service.

---

### WARNING



Do not attempt to open and modify the motor. This manual describes modifications that you can perform in the field. Do not attempt other changes.

Only a qualified Allen-Bradley employee can service this type of motor.

Failure to observe these safety procedures could result in personal injury or damage to equipment.

---

## Installation and Maintenance Guidelines

The guidelines in this section advise you on how to install your product so it provides safe and reliable service.

---

### WARNING



Avoid spraying liquids under high pressure directly on the connectors, as well as directly on the motor and enclosure joints.

Fluids under high pressure can be forced into the connectors, resulting in an electrical short circuit. Fluids also can be forced around worn seals, and contaminate the motor bearings. Bearing contamination significantly shortens the life of a servo motor.

The motor has 3 m (9.8 ft) cables with nickel-plated connectors for motor power and feedback. These connectors are not designed to withstand high pressure washdown or washdown with aggressive cleaning compounds. Position connectors away from direct exposure to cleaning processes, for example within washdown-rated conduit or junction boxes.

Failure to observe these safety procedures could result in personal injury or damage to equipment.

---

## To Prolong Motor Life

Thoughtful design and proper maintenance can increase the life of a servo motor. Use these guidelines to maximize the life of a servo motor within a food processing environment:

- Always install the motor with the cable entry point positioned underneath the motor housing, and provide a drip loop in each cable. A drip loop is a downward bend in the cable that lets water gather and drip off the cable rather than continue to flow along the cable. These two installation practices greatly reduce issues caused by moisture.

### Recommended Connector Orientation with Drip Loop

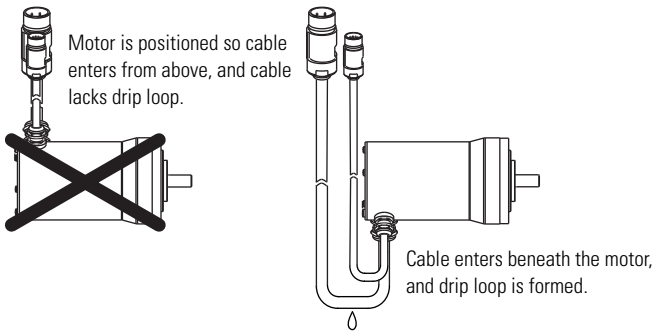

- Avoid installing the motor with the shaft pointing upward. This orientation increases the risk of contaminant ingress.
- Avoid spraying liquids under high pressure directly on the junction of the motor shaft, housing, and connectors, as well as the enclosure joints. Fluids under high pressure can be forced around worn seals, and may contaminate the motor bearings. Bearing contamination significantly shortens the life of a servo motor.
- If design requirements permit, provide shields or junction boxes that protect the motor housing, shaft seals, connectors, and their junctions from product contamination, caustic agents, and high pressure fluids.
- Replace the shaft seal at or before its expected 12 month lifetime elapses. Refer to Removing and Installing a Shaft Key on page 19 for more information on shaft seals.
- Inspect the motor and seals for damage or wear on a regular basis. If damage or adverse wear is suspected, replace the item.
- If desired, seal the motor front flange to the driven equipment with a bead of food-grade RTV around the periphery of the motor to equipment joint. Use of a gasket or RTV on the mating surfaces may cause misalignment of the shaft and result in damage to the motor and driven equipment.

- Brakes on these servo motors are holding brakes. The brakes are spring-set, and release when voltage is applied to the brake coil. Use a power source, either external or internal to the servo drive, to disengage the brake. You can apply a servo motor controller to this power source, in addition to manual operator control. Brakes on these servo motor are holding brakes. The brakes are spring-set, and release when voltage is applied to the brake coil. Verify that the power circuit for the motor brake includes a suppression device, either a metal oxide varistor (MOV) or diode, as shown in the figure.

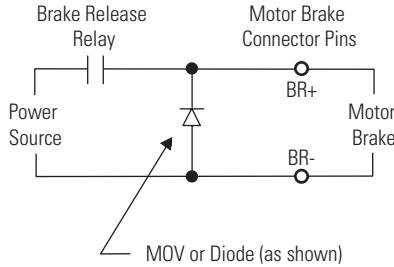

If system main power fails, holding brakes can withstand occasional use as stopping brakes. However, this creates rotational mechanical backlash that is potentially damaging to the system, increases brake wear, and reduces brake life.

---

**IMPORTANT**

Holding brakes are not designed to stop rotation of the motor shaft, nor are they intended to be used as a safety device. The brake is designed to hold a motor shaft at 0 rpm for up to the rated holding torque.

To prevent shaft rotation, follow these steps:

1. Command the servo drive to 0 rpm.
2. Verify the motor is at 0 rpm.
3. Engage the brake.
4. Disable the drive.

Disabling the drive removes the potential for brake wear caused by a badly-tuned servo system oscillating the shaft.

---

### *Mechanical Connections*

Mechanical connections to the motor shaft, such as couplings and pulleys, require a torsionally rigid coupling or a reinforced timing belt. The high dynamic performance of servo motors can cause couplings, pulleys, or belts to loosen or slip over time. A loose or slipping connection causes system instability and may damage the motor shaft. All connections between the machine and the motor shaft must be rigid to achieve acceptable system response. Periodically inspect connections to verify their rigidity.

When mounting couplings or pulleys to the shaft, verify that the connections are properly aligned and that axial and radial loads are within the specifications of the motor.

Refer to Motor Load Force Ratings on page 15 for guidelines on how to achieve 20,000 hours of motor bearing life.

**ATTENTION**

Do not strike the shaft, key, couplings, or pulleys with tools during installation or removal.

Damage may occur to the motor bearings and the feedback device if a sharp impact is applied to the shaft during installation of couplings and pulleys, or to remove the shaft key.

Damage to the feedback device also may result from applying leverage from the faceplate to remove devices mounted on the motor shaft.

Apply a constant pressure, with a wheel puller for example, to the user end of the shaft to remove a friction fit or a stuck device.

Failure to observe these safety procedures could result in damage to the motor and its components.

A shaft key provides a rigid mechanical connection with the potential for self-alignment, but the key must be properly installed in the keyway. Refer to these sections for additional information:

- Dimensions on page 13 for information about the key and shaft keyway dimensions.
- Removing and Installing a Shaft Key on page 19 for recommendations on how to remove and install a shaft key.

### *Interconnect Cables*

Knowledgeable cable routing improves system electromagnetic compatibility (EMC). Refer to Shielding of Signal Wires within the Power Cable (2090-XXNPMF-xxSxx) on page 10 for suggested cable trim lengths, and for cable shield grounding at the motor frame.

To install the cables, follow these steps:

1. Keep wire lengths as short as physically possible.
2. Route signal cables away from motor and power wiring.

Typical signal cables transmit encoder, serial, or analog data at low voltages.

3. Separate cables by a minimum of 0.3 m (1 ft) for every 9 m (30 ft) of parallel run.

4. Ground both ends of the cable shield and twist the signal wire pairs to prevent electromagnetic interference from other equipment.

---

**WARNING**

High voltage can be present on the shields of a power cable, if the shields are not grounded.

Verify there is a connection to ground for all shields in the power cable.

Failure to observe these safety procedures could result in personal injury or damage to equipment.

---

### *Electrical Noise*

Electromagnetic interference (EMI), commonly called noise, may adversely impact motor performance by inducing stray signals. Effective techniques to counter EMI include filtering the ac power, shielding and separating signal carrying lines, and practicing good grounding techniques. Effective ac-power filtering can be achieved by using isolated ac-power transformers or properly installed ac line filters.

To reduce EMI, follow these guidelines:

- Physically separate signal lines from motor cabling and power wiring. Do not route signal wires with motor and power wires, and do not route signal wires over the vent openings of servo drives or other electrical power sources.
- Ground all equipment through a single-point parallel ground system that employs ground bus bars or large straps. If necessary, use additional electrical-noise reduction techniques to reduce EMI in noisy environments.

### *Shaft Seals*

A seal is installed on the motor shaft to protect the front bearing from fluids or fine dust that could contaminate the motor bearing and reduce its lifetime. The IP66, IP67, or IP69K rating for the motor depends on the usage of shaft seals and environmentally sealed connectors and cables.

- Refer to Shaft Seal and Slinger Kits on page 24 to find the catalog numbers of seal kits available for your motor.
- Refer to Specifications on page 23 for brief descriptions of IP ratings.
- Refer to Kinetix Motion Control Selection Guide, publication GMC-SG001, to find environmentally sealed cables compatible with the MPS motors.



---

## Installing the Motor

Before mounting and connecting the motor, review and become familiar with these steps:

- Motor Mounting Requirements
- Power Cable Shielding
- Mounting and Connecting the Motor
- Motor Connections
- Motor Load Force Ratings
- Dimensions

### Motor Mounting Requirements

All MPS motors include a mounting pilot for aligning the motor on a machine. Preferred fasteners are stainless steel. The installation must comply with all local regulations and use of equipment and installation practices that promote electromagnetic compatibility and safety.

---

**WARNING**

Unmounted motors, disconnected mechanical couplings, loose shaft keys, and disconnected cables are dangerous if power is applied.

Disassembled equipment should be appropriately identified (tagged-out) and access to electrical power restricted (locked-out).

Before applying power to the motor, remove the shaft key and other mechanical couplings that could be thrown from the shaft.

Failure to observe these safety procedures could result in personal injury or damage to equipment.

---

### Power Cable Shielding

Power cables must be shielded, and the cable shield must connect to ground.

---

**WARNING**

High voltage can be present on the shields of a power cable, if the shields are not grounded.

Verify there is a connection to ground for all shields in the power cable.

Failure to observe these safety procedures could result in personal injury or damage to equipment.

---

Verify the separate signal-wire shield connect to the overall chassis ground by looping back each of the signal wire pairs as shown in *Shielding of Signal Wires* within the Power Cable (2090-XXNPMF-xxSxx). Clamp all three shields together at the power cable (chassis) ground connection on the drive.

### Shielding of Signal Wires within the Power Cable (2090-XXNPMF-xxSxx)

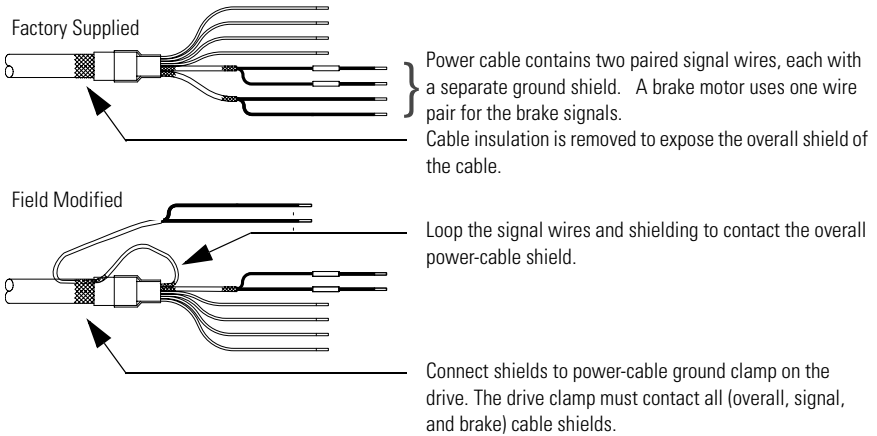

### Mounting and Connecting the Motor

To install an MPS motors, follow these procedures and recommendations:

---

**ATTENTION**



Servo motors are not for direct connection to an ac power line.

Servo motors are designed for connection to a servo drive that controls the application of ac power.

Failure to observe these safety precautions could result in damage to the motor and equipment.

---

**ATTENTION**



Do not strike the shaft, couplings, or pulleys with tools during installation or removal.

Damage may occur to the motor bearings and the feedback device if you apply a sharp impact to the shaft during installation of couplings and pulleys, or a shaft key.

Failure to observe these safety procedures could result in damage to the motor and its components.

---

1. Allow sufficient clearances in the area of the motor for it to stay within its specified operating temperature range.

Do not install the motor in an area with restricted airflow. Keep other heat producing devices away from the motor.

**WARNING**

Outer surfaces of the motor can reach high temperatures, 125 °C (275 °F) during motor operation.

Take precautions to prevent accidental contact with hot surfaces. Consider motor surface temperature when selecting motor mating connections and cables.

Failure to observe these safety procedures could result in personal injury or damage to equipment.

- Obtain the specified motor thermal rating by mounting the motor on a surface with heat dissipation equivalent to a 304.8 x 304.8 x 12.7 mm (12 x 12 x 0.5 in.) aluminum heatsink.
  - Refer to Specifications on page 23 for the operating range.
  - Do not install the motor in an area with restricted airflow, and keep other heat producing devices away from the motor.
2. Refer to Motor Load Force Ratings on page 15 to determine the radial and axial shaft load limitations of your motor.
  3. Position the motor with the cable connections beneath the motor.

Refer to Recommended Connector Orientation with Drip Loop on page 5 for a visual reference of correct motor and cable positioning.

4. Properly mount and align the motor.

The index pulse occurs on a single-turn encoder when the shaft key is aligned with the connectors. Refer to Dimensions on page 13 for a visual reference of this alignment.

5. Form a drip loop in the cables directly before each cable enters the motor.

A drip loop lets liquids gather and drip off the cable rather than flow along the cable to an electrical connection or the motor. Refer to Recommended Connector Orientation with Drip Loop on page 5 for a visual example.

**ATTENTION**

Be sure that cables are installed and restrained to prevent uneven tension or flexing at the cable connectors.

Excessive and uneven lateral force at the cable connectors may result in the connector's environmental seal opening and closing as the cable flexes.

Failure to observe these safety procedures could result in damage to the motor and its components.

**ATTENTION**



Servo drive power must be turned off before connecting or disconnecting the cables to the motor, and if a cable is left disconnected at the motor end.

Arcing or unexpected motion could occur if the feedback, power, or brake cables are connected or disconnected while power is applied to the servo drive.

Failure to observe these safety procedures could result in personal injury or damage to the motor and equipment.

---

6. Connect the feedback cable, and the combined power and brake cable after the motor is mounted.
- 

**ATTENTION**



Keyed connectors must be properly aligned and hand-tightened the recommended number of turns.

Improper connector alignment is indicated by the need for excessive force, such as the use of tools, to fully seat connectors.

Failure to observe these safety procedures could result in damage to the motor, cables, and connector components.

---

- a. Carefully align each cable connector with the respective motor connector as shown in Visual Cues for Cable Connector Alignment.

Do not apply excessive force when mating the cable and motor connectors. If the connectors do not go together with light hand force, realign and try again.

- b. Hand tighten the knurled collar five to six turns to fully seat each connector.

**Visual Cues for Cable Connector Alignment**

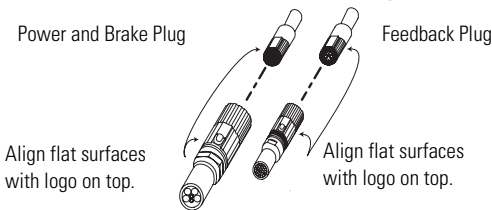

## Dimensions

Refer to the tables beginning on page 14 for the dimension symbols and physical dimensions for the different frame sizes and stack lengths of MPS motors.

### References for Motor Mounting Dimensions

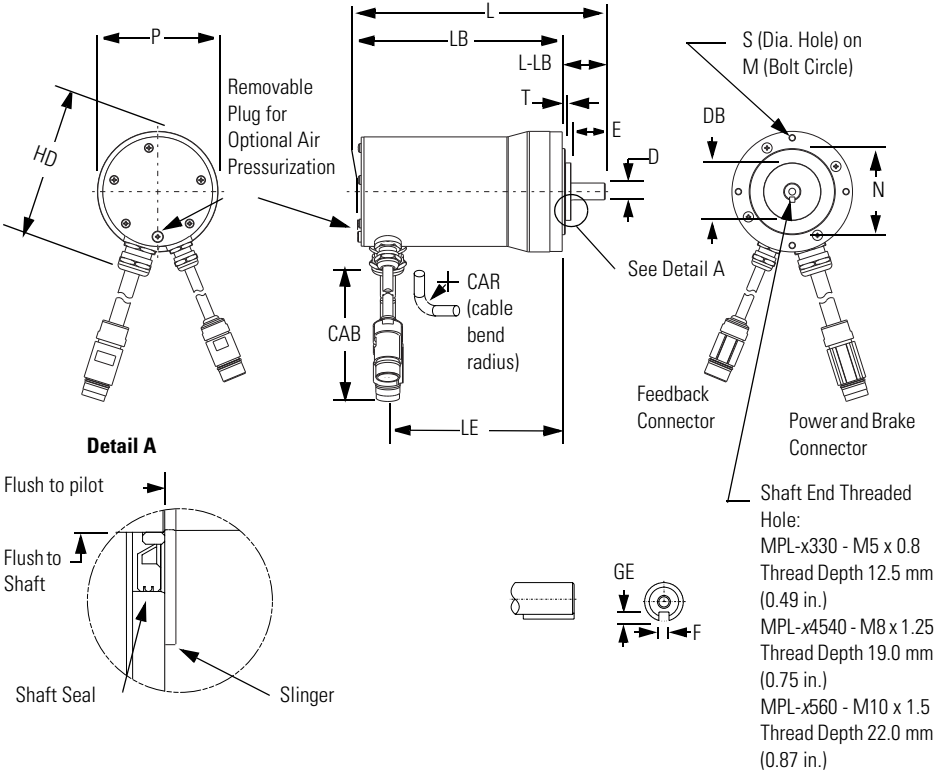

1. Cable length measurement does not include mounting hardware or connector.
2. LE measures to center of connectors

Catalog number MPS-x330x faceplate shown above.

Catalog numbers MPS-x4540x and MPS-x560x have additional housing screws evenly distributed.

MPS motors are designed to metric dimensions. Inch dimensions are mathematical conversions from millimeters.

The dimensions in the table are for non-brake motors with a single-turn encoder. Footnotes provide the additional dimensions for the brake options, and the tolerances for common dimensions.

**MP-Series Stainless Steel Motor Dimensions**

MPS-A or MPS-B	D <sup>(1)</sup>	DB	E	HD	L <sup>(2), (3)</sup>	L-LB <sup>(2), (3)</sup>	LB	LE <sup>(4)</sup>	M
	mm (in.)	mm (in.)	mm (in.)	mm (in.)	mm (in.)	mm (in.)	mm (in.)	mm (in.)	mm (in.)
330	16.0 (0.63)	50.8 (2.0)	32.13 (1.26)	135.0 (5.31)	230.0 (9.06)	40.0 (1.58)	190.0 (7.49)	162.0 (6.38)	100.0 (3.94)
4540	24.0 (0.945)	63.5 (2.50)	41.4 (1.63)	164.0 (6.46)	266.0 (10.45)	50.0 (1.97)	216.0 (8.48)	185.0 (7.30)	130.0 (5.12)
560	28.0 (1.1024)	82.6 (3.25)	56.62 (2.229)	198 (7.79)	396 (15.60)	60.0 (2.362)	336 (13.24)	302 (11.90)	165 (6.496)

(1) Tolerance for this dimension is: MPS-x330 +0.008, -0.003 (+0.0001, -0.0002) MPS-x4540 +0.009, -0.004 (+0.0001, -0.0002); and MPS-x560 +0.009, -0.004 (+0.0003, -0.0002).

(2) Tolerance for this dimension is ±0.7 (±0.28).

(3) If ordering an MPS-x330 motor with brake, add 35.0 mm (1.38 in.) to L and LB, and 34.0 mm (1.34 in.) to LE.  
 If ordering an MPS-x4540 motor with brake, add 48.5 mm (1.91 in.) to L, LB, and LE.  
 If ordering an MPS-x560 motor with brake, add 51.6 mm (2.03 in.) to dimensions L, LB, and LE.

**MP-Series Stainless Steel Motor Dimensions (cont.)**

MPS-A or MPS-B	N <sup>(1)</sup>	P <sup>(2)</sup>	S <sup>(3)</sup>	T	CAB <sup>(4)</sup>	CAR <sup>(5)</sup> Pwr	CAR <sup>(3)</sup> Fdbk	F <sup>(6)</sup>	GE <sup>(7)</sup>
	mm (in.)	mm (in.)	mm (in.)	mm (in.)	mm (in.)	mm (in.)	mm (in.)	mm (in.)	mm (in.)
330	80.0 (3.15)	112.0 (4.41)	M6 x 1.0 x 7 (0.28)	2.87 (0.113)	3000.0 (118.1)	148.0 (5.84)	96.52 (3.80)	5.0 (0.197)	3.0 (0.118)
4540	110.0 (4.331)	143.2 (5.64)	M8 x 1.25 - 6H x 9.0 (0.35)	3.38 (0.133)	3000.0 (118.1)	148.0 (5.84)	96.52 (3.80)	8.0 (0.315)	4.0 (0.158)
560	130 (5.118)	181 (7.13)	M10 x 1.5 - 6H x 11 (0.43)	3.38 (0.133)	3000.0 (118.1)	187.0 (7.37)	96.52 (3.80)	8.0 (0.315)	4.0 (0.158)

(1) Tolerance for this dimension is: MPS-x330 +0.012, -0.007 (+0.0001, -0.0007); MPS-x4540 +0.013, -0.009 (+0.0001, -0.0002); and MPS-x560 +0.014, -0.009 (+0.0007, -0.0002).

(2) This dimension is the largest diameter on the motor housing.

(3) Metric (M) threading dimensions include major diameter (mm) X thread pitch - tolerance class X thread depth in mm and (in.).

(4) This dimension includes the total length of the cable and the connector.

(5) Factory cables do not have a continuous flex rating, the specified cable bend radius is a one-time bend.

(6) Tolerance for this dimension is: MPS-x330 -0.03 (-0.001); MPS-x4540 -0.04 (-0.001); and MPS-x560 -0.04 (-0.001).

(7) Tolerance for this dimension is: MPS-x330 +0.1 (+0.004); MPS-x4540 +0.2 (+0.007); and MPS-x560 +0.2 (+0.007).

## Motor Load Force Ratings

Motors can operate with a sustained shaft load. The figure shows radial and axial load force locations, and the tables provide maximum values for each.

### Load Forces on Shaft

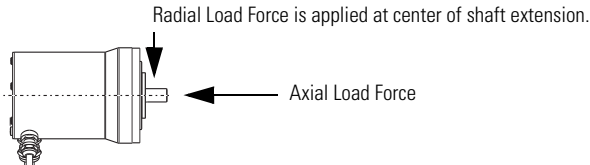

The tables represent 20,000 hour L10 bearing fatigue life at various loads and speeds. The 20,000 hour life does not account for possible application-specific life reduction that may occur due to bearing grease contamination from external sources.

Loads are measured in pounds; kilograms are mathematical conversions.

### Radial Load Force Ratings

Motor	500 rpm		1000 rpm		2000 rpm		3000 rpm		3500 rpm		4000 rpm		5000 rpm	
	kg	(lb)	kg	(lb)	kg	(lb)	kg	(lb)	kg	(lb)	kg	(lb)	kg	(lb)
MPS-A/B330	—	—	74	(163)	59	(130)	—	—	49	(108)	—	—	43	(95)
MPS-A/B4540	140	(309)	111	(245)	89	(195)	77	(170)	—	—	—	—	—	—
MPS-A/B560	—	—	154	(338)	122	(268)	106	(234)	—	—	—	—	—	—

### Axial Load Force Ratings with Maximum Radial Load

Motor	500 rpm		1000 rpm		2000 rpm		3000 rpm		3500 rpm		4000 rpm		5000 rpm	
	kg	(lb)	kg	(lb)	kg	(lb)	kg	(lb)	kg	(lb)	kg	(lb)	kg	(lb)
MPS-A/B330	—	—	27	(59)	20	(44)	—	—	16	(35)	—	—	13	(29)
MPS-A/B4540	49	(107)	36	(80)	27	(59)	22	(49)	—	—	—	—	—	—
MPS-A/B560	—	—	52	(115)	39	(85)	32	(71)	—	—	—	—	—	—

### Axial Load Force Ratings with Zero Radial Load

Motor	500 rpm		1000 rpm		2000 rpm		3000 rpm		3500 rpm		4000 rpm		5000 rpm	
	kg	(lb)	kg	(lb)	kg	(lb)	kg	(lb)	kg	(lb)	kg	(lb)	kg	(lb)
MPS-A/B330	—	—	36	(79)	27	(59)	—	—	21	(46)	—	—	18	(40)
MPS-A/B4540	69	(152)	51	(112)	38	(83)	31	(69)	—	—	—	—	—	—
MPS-A/B560	—	—	68	(149)	50	(109)	42	(92)	—	—	—	—	—	—

## Motor Connections

These tables contain connector pin descriptions for the feedback connector, and the combined power and brake connector on the MPS motor.

Feedback		
Pin	High Resolution Encoder for 230V Motors (MPS-Axxx)	High Resolution Encoder for 460V Motors (MPS-Bxxx)
1	Sin+	Sin+
2	Sin-	Sin-
3	Cos+	Cos+
4	Cos-	Cos-
5	Data+	Data+
6	Data-	Data-
7	Reserved	Reserved
8		
9		
10		
11	Reserved	EPWR 9V
12		ECOM
13	TS+	TS+
14	TS-	TS-
15	Reserved	Reserved
16		
17		

Intercontec Part Number AKUA034MR04120035000

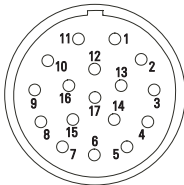

Power and Brake	
Pin	MPS-Axxx and MPS-Bxxx
A	Phase U
B	Phase V
C	Phase W
D	Ground
E	Reserved
F	MBRK+
G	MBRK-
H	Reserved
L	

Intercontec Part Number  
BKUA090MR26590035000

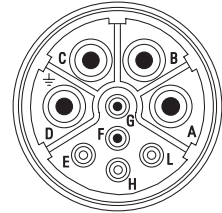

1 The U, V, and W power phases may be labelled as R, S, and T respectively.



## Motor Cables

Use these figures to identify the cable wiring for 230V motors (catalog number MPS-Axxx) or 460V motors (catalog number MPS-Bxxx).

This figure depicts the wiring of a power and brake cable for a 230V or 460V motor.

### Power/Brake Cable Schematic

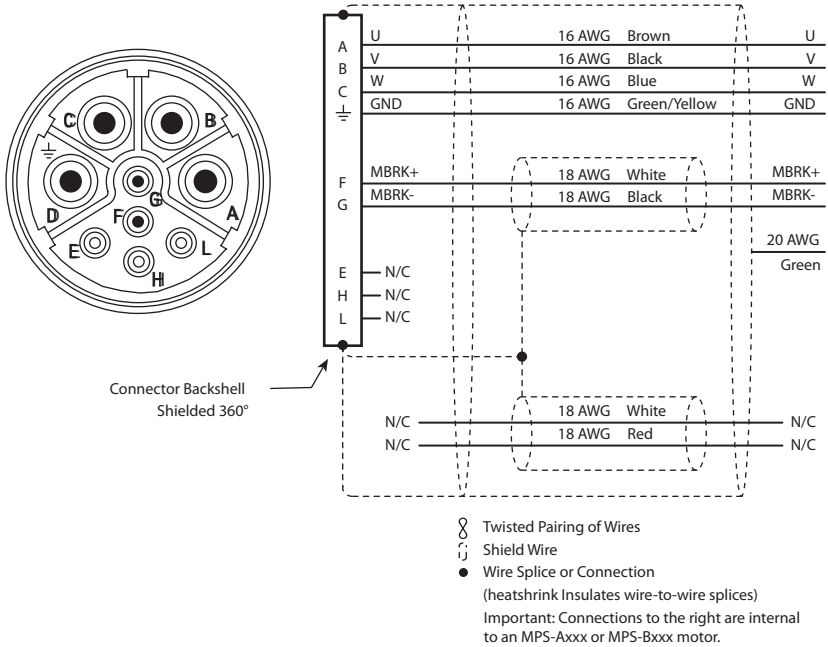

### Feedback Cable Schematics

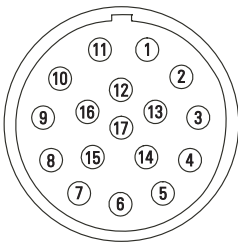
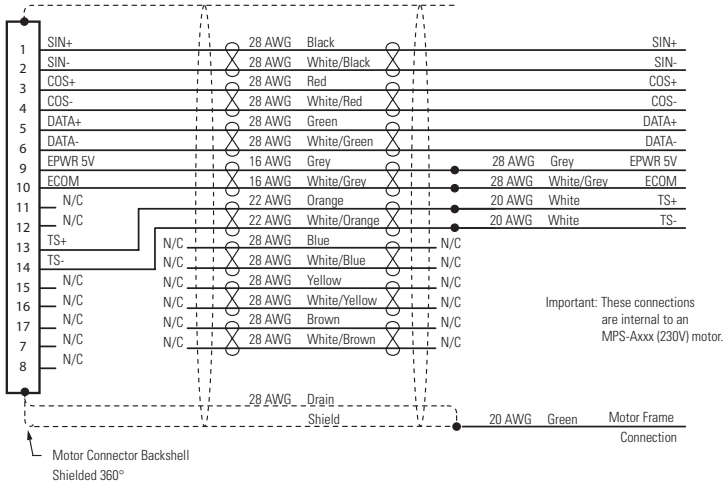

- Twisted Pairing of Wires
- Shield Wire
- Wire Splice or Connection (heatshrink Insulates wire-to-wire splices)

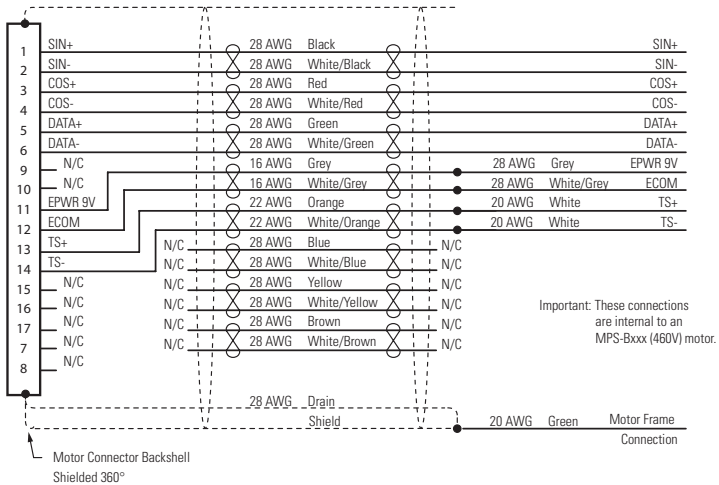

## Removing and Installing a Shaft Key

Shaft keys for the MPS motors are constructed of Stainless steel - 300 series and tolerated for interference fit (slightly larger than the opening) to provide a secure and rigid fit for the mating connection.

### ATTENTION



Do not strike the shaft, couplings, or pulleys with tools during installation or removal of the shaft key.

Damage may occur to the motor bearings and the feedback device if a sharp impact is applied to the shaft during installation of couplings and pulleys, or to remove the shaft key, or if leverage is applied from the motor mounting face to remove devices mounted on the motor shaft.

Apply a constant pressure, with a wheel puller, to the user end of the shaft to remove a friction fit or stuck device.

Failure to observe these safety procedures could result in damage to the motor and its components.

To remove a shaft key, perform one of these actions:

- Lift the key by grasping it with a plier or similar tool.
- Lever the key with a screwdriver inserted between the key and the slot.

To install a shaft key, follow these steps:

1. Verify the replacement key matches the keyway in the shaft and the mating mechanical connection (for example, a coupling or pulley) before proceeding.
2. Align the front of the key with the front of the motor shaft.

This prevents the radiused end-of-cut at the motor end of the keyway from interfering with correct seating of the key.

3. Support the underside of the shaft diameter with a fixture, and use a controlled press device to apply a constant force across the top surface to press the key into the shaft.

### Key Alignment and Shaft Support

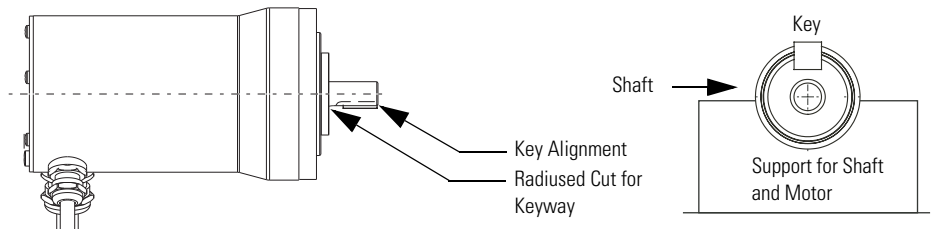

## Slinger and Shaft Seal Removal and Installation

Shaft seals that provide environmental sealing of MPS motors are available from Allen-Bradley. Shaft seals provide an additional barrier to moisture and particle intrusion to the motor bearings. Motors are shipped with a PolyTetraFluoroEthylene (PTFE) shaft seal installed.

Lubricate shaft seals with a food-grade polyurea base grease, such as Chevron FM (NLGI 2), which is included with shaft seal kits. Replace shaft seals every 12-months.

---

**IMPORTANT**

Damage to the motor surface where the slinger and shaft seals make contact can cause excessive wear and early failure of the slinger and shaft seal.

Use care to prevent scratching or damaging the surface of the motor.

Failure to observe these safety procedures could result in damage to equipment.

---

Remove the slinger and shaft seal by carefully lifting around the outside edge of the slinger or seal with a small screwdriver.

## Install a Shaft Seal

To install a shaft seal, follow these steps:

1. Remove the shaft key, if present.

Proper removal technique is limited to these actions:

- Grasping and lifting the key with a plier or similar tool.
- Levering the key with a screwdriver inserted between the key and the slot.

---

**ATTENTION**

Do not strike the shaft, couplings, or pulleys with tools during installation or removal of the shaft key.

Damage may occur to the motor bearings and the feedback device if a sharp impact is applied to the shaft during installation of couplings and pulleys, or to remove the shaft key, or if leverage is applied from the motor mounting face to remove devices mounted on the motor shaft.

Apply a constant pressure, with a wheel puller, to the user end of the shaft to remove a friction fit or stuck device.

Failure to observe these safety procedures could result in damage to the motor and its components.

---

2. Remove the slinger from the shaft.

Proper removal technique is limited to these actions:

- Grasping the slinger with a plier or similar tool.
  - Levering around the slinger with a screwdriver inserted between the slinger and the pilot.
  - Using a wheel or gear puller.
3. Remove the shaft seal by carefully lifting with a screwdriver around the outside edge of the seal.
  4. Visually inspect the motor and the new shaft seal.

Verify the seal is undamaged, and the motor shaft, faceplate, bearing bore, wear sleeve, and keyway where the shaft seal will make contact during installation and motor use is free from nicks, burrs, grooves, or spiral machine marks.

---

**IMPORTANT**

Check the motor shaft and surrounding surfaces. Remove any nicks, burrs, or surface damage. Significant grooving or damage will require service by Rockwell Automation to provide appropriate seal performance.

---

5. Protect the seal lip from the sharp edges of the keyway.

If necessary, place masking tape over the keyway or use a coned assembly sleeve as shown in Shaft Seal Installation for MPS Motors on page 22.

6. Position the seal on the shaft with the sealing lip positioned and slanting outward as shown in Shaft Seal Installation for MPS Motors on page 22.
7. Apply a bead of lubricant to the area around the internal sealing lip, as well as to the shaft.

Do not apply an excessive amount of lubricant, and do not apply lubricant to the sealing o-ring.

---

**IMPORTANT**

Do not bottom out the shaft seal. Proper seating of the shaft seal to a specific depth is important to prolong motor life.

Insert the shaft seal so the outer diameter of the seal is 1.0 mm (0.04 in.) beneath the front surface of the motor.

---

8. Apply these techniques when using tools to seat the shaft seal:
- Avoid canting or angling the seal, and do not hammer directly on shaft seal.
  - Applying an even force around the outer edge with a soft face tool, arbor press, or a work piece made from soft wood.

The seating tool should barely slide over the motor shaft while its outside diameter should be sufficiently thick to contact the motor mounting surface. This distributes installation forces evenly across the front of the shaft seal, prevents canting of the seal, and physically prevents the shaft seal seating too deep in the bearing bore. Leave a 1 mm (0.04 in.) clearance between the front surface of the shaft seal and that of the retaining ring.

### Shaft Seal Installation for MPS Motors

Exploded view of shaft seal seated beneath the front surface of the motor.



1 mm  
(0.04 in.)

Proper seating provides necessary clearance between shaft seal and retaining ring.

The retaining ring and coned assembly sleeve are shaded in this figure.

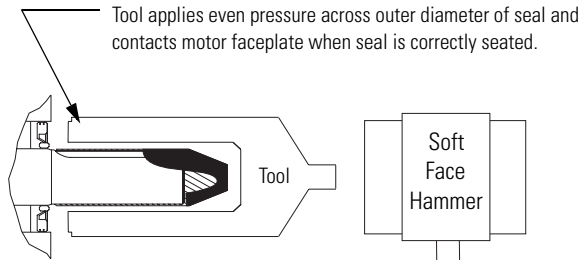

Shown with coned assembly sleeve covering motor shaft.

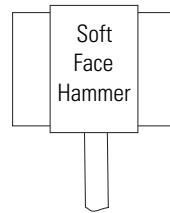

9. Reinstall the slinger and, if present, the shaft key as described on page 19.

## Specifications

The exterior surfaces of the MP-Series Stainless Steel Servo Motors are made from the materials in the table. Always store a motor in a clean and dry location within the environmental conditions.

### Exterior Surface Materials

Surface	Material
Shaft	Stainless steel - grade 303
Shaft key	Stainless steel - 300 series
Housing	Stainless steel - grade 304
Connector	Nickel-plated zinc casting

### Environmental Specifications

Attribute	Value
Temperature, operating	0...40 °C (32...104 °F)
Temperature, storage	-30...70 °C (-2...158 °F)
Relative humidity	5...95% noncondensing
Atmosphere	Noncorrosive
Motor housings are rated with multiple International Protection Codes (IP ratings) for environmental protection	
IP66	Dust tight, powerful water jets, room temperature water <sup>(1)</sup>
IP67	Dust tight, temporary immersion, room temperature water <sup>(1)</sup>
IP69K	Dust tight, water/steam jets up to 100 bar (1200 psi) with nozzle pressure at approximately 80 °C (176 °F) <sup>(1)</sup>

Connectors are IP66 and IP67 rated <sup>(1)</sup>

<sup>(1)</sup> IP rating descriptions are for reference only. Refer to the international standards for more complete rating descriptions.

#### WARNING



Avoid spraying liquids under high pressure directly on the connectors.

The connectors are not designed to withstand high pressure washdown or washdown with aggressive cleaning compounds. Position connectors away from direct exposure to cleaning processes, for example within washdown-rated conduit or junction boxes.

Failure to observe these safety procedures could result in personal injury or damage to equipment.

## Motor Cables and Accessory Kits

Accessories available from the factory include these items.

### Motor Cables

Factory manufactured feedback and power cables are available in standard cable lengths. They provide the sealing needed to achieve environmental ratings and shield termination.

For a complete listing of available cables, contact your nearest Rockwell Automation sales office or refer to the Kinetix Motion Control Selection Guide listed on page 26.

### Shaft Seal and Slinger Kits

MPS Shaft Seal and Slinger Kits catalog numbers and dimensions are in the table.

Motor	Catalog Number	Shaft Seal			Slinger		
		Inside Dia.	Outside Dia.	Width	Inside Dia.	Outside Dia.	Width
		mm (in.)	mm (in.)	mm (in.)	mm (in.)	mm (in.)	mm (in.)
MPS-A330, and B330	MPS-SST-A3B3	23 (0.90)	47 (1.85)	6 (0.24)	16.0 (0.63)	50.8 (2.0)	5.10 (0.20)
MPS-A4540, and B4540	MPS-SST-A45B45	31 (1.22)	62 (2.44)	7 (0.27)	24.0 (0.945)	63.5 (2.50)	5.10 (0.20)
MPS-A560, and B560	MPS-SST-F165	36 (1.42)	72 (2.84)	8 (0.315)	28.0 (1.1024)	82.6 (3.25)	5.10 (0.20)

Shaft seals require a food-grade polyurea lubricant to reduce wear. Lubricant is provided with kit.

### Sealing Air Accessory Kit

A sealing air pressure kit (catalog number MPS-AIR-PURGE) is available for field installation on MPS motors.

The kit provides a quick-release female air fitting. Positive air pressure applied to the motor provides an additional level of protection against the ingress of foreign substances and moisture.

#### *Sealing Air Accessory Kit Guidelines*

You must supply these items, with the sealing plug:

- Plastic air tubing should be 4 mm (5/32 in.) OD Teflon FEP tubing.
- Air supplied to the motor should not exceed 0.1 bar (1.45 psi).



**ATTENTION**

Excessive air pressure and improper filtering of air can result in damage to the motor.

Air supplied to the motor must be clean, dry, and of instrument quality. Maximum air pressure should be 0.1 bar (1.45 psi).

Failure to observe these safety procedures could result in personal injury or damage to equipment.

---

### *Sealing Air Accessory Kit Installation*

1. Remove the 5 mm (0.20 in.) sealing plug with a Phillips screwdriver.
2. Inspect the air fitting and motor opening to verify the surface area is undamaged, and the contact area is clean.

Torque the air fitting to 1.1...1.2 Nm (10...12 lb-in).

3. Visually inspect the circumference of the connection for proper seating.

# Additional Resources

For additional information about motors and compatible Rockwell Automation drives, refer to these publications.

For	Read This Publication	Publication Number
Connecting to a drive.	Kinetix 2000 Multi-axis Servo Drive User Manual	2093-UM001
	Kinetix 6000 Multi-axis Servo Drive User Manual	2094-UM001
	Ultra3000 Digital Servo Drive Installation Manual	2098-IN003
	Ultra3000 Digital Servo Drive Integration Manual	2098-IN005
Installing a shaft seal	Shaft-seal Kit Installation Instructions	2090-IN012
A glossary of industrial automation terms and abbreviations	Allen-Bradley Industrial Automation Glossary	AG-7.1
How to minimize and control system-level noise	System Design for Control of Electrical Noise Reference Manual	GMC-RM001
An overview of Allen-Bradley motion controls and systems, including information about this and other motors	Kinetix Motion Control Selection Guide	GMC-SG001

You can view or download publications at <http://literature.rockwellautomation.com>. To order paper copies of technical documentation, contact your local Rockwell Automation distributor or sales representative.

Allen-Bradley, Kinetix, Rockwell Automation, TechConnect, and Ultra3000 are trademarks of Rockwell Automation, Inc.

Trademarks not belonging to Rockwell Automation are property of their respective companies.

[www.rockwellautomation.com](http://www.rockwellautomation.com)

#### Power, Control and Information Solutions Headquarters

Americas: Rockwell Automation, 1201 South Second Street, Milwaukee, WI 53204-2496 USA, Tel: (1) 414.382.2000, Fax: (1) 414.382.4444  
Europe/Middle East/Africa: Rockwell Automation, Vortlaan/Boulevard du Souverain 36, 1170 Brussels, Belgium, Tel: (32) 2.663.0600, Fax: (32) 2.663.0640  
Asia Pacific: Rockwell Automation, Level 14, Core F, Cyberport 3, 100 Cyberport Road, Hong Kong, Tel: (852) 2887.4788, Fax: (852) 2508.1846

Publication MP-IN005D-EN-P - November 2007

PN-14887

Supersedes Publication MP-IN005C-EN-P - October 2005

Copyright © 2007 Rockwell Automation, Inc. All rights reserved. Printed in the U.S.A.