

LDC-Series Iron Core Linear Servo Motors



Catalog Numbers

**LDC-C030xxx-xHT11, LDC-C050xxx-xHT11, LDC-C075xxx-xHT11,
LDC-C100xxx-xHT11, LDC-C150xxx-xHT11**

**LDC-C030xxx-xHT20, LDC-C050xxx-xHT20, LDC-C075xxx-xHT20,
LDC-C100xxx-xHT20, LDC-C150xxx-xHT20**

LDC-M030xxx, LDC-M050xxx, LDC-M075xxx, LDC-M100xxx, LDC-M150xxx

**LDC-030-xxx-CP, LDC-050-xxx-CP, LDC-075-xxx-CP,
LDC-100-xxx-CP, LDC-150-xxx-CP**

User Manual

Important User Information

Solid state equipment has operational characteristics differing from those of electromechanical equipment. Safety Guidelines for the Application, Installation and Maintenance of Solid State Controls (publication [SGI-1.1](#) available from your local Rockwell Automation sales office or online at <http://literature.rockwellautomation.com>) describes some important differences between solid state equipment and hard-wired electromechanical devices. Because of this difference, and also because of the wide variety of uses for solid state equipment, all persons responsible for applying this equipment must satisfy themselves that each intended application of this equipment is acceptable.





In no event will Rockwell Automation, Inc. be responsible or liable for indirect or consequential damages resulting from the use or application of this equipment.

The examples and diagrams in this manual are included solely for illustrative purposes. Because of the many variables and requirements associated with any particular installation, Rockwell Automation, Inc. cannot assume responsibility or liability for actual use based on the examples and diagrams.

No patent liability is assumed by Rockwell Automation, Inc. with respect to use of information, circuits, equipment, or software described in this manual.

Reproduction of the contents of this manual, in whole or in part, without written permission of Rockwell Automation, Inc., is prohibited.

Throughout this manual, when necessary, we use notes to make you aware of safety considerations.

WARNING 	Identifies information about practices or circumstances that can cause an explosion in a hazardous environment, which may lead to personal injury or death, property damage, or economic loss.
IMPORTANT	Identifies information that is critical for successful application and understanding of the product.
ATTENTION 	Identifies information about practices or circumstances that can lead to personal injury or death, property damage, or economic loss. Attentions help you identify a hazard, avoid a hazard, and recognize the consequence
SHOCK HAZARD 	Labels may be on or inside the equipment, for example, a drive or motor, to alert people that dangerous voltage may be present.
BURN HAZARD 	Labels may be on or inside the equipment, for example, a drive or motor, to alert people that surfaces may reach dangerous temperatures.

Allen-Bradley, Rockwell Automation, Kinetix, Ultra3000, LDC-Series Iron Core Linear Servo Motors, RSLogix 5000, and TechConnect are trademarks of Rockwell Automation, Inc.

Trademarks not belonging to Rockwell Automation are property of their respective companies.

	Preface	
	About This Publication	7
	Who Should Use This Manual	7
	Additional Resources.	7
	Chapter 1	
Safety Considerations	Introduction	9
	Labels.	9
	High Energy Magnets	10
	Unpacking and Handling	10
	Air Freight Restrictions	11
	Vertical or Incline Installation	12
	Operational Guidelines	13
	Chapter 2	
Start	Introduction	15
	Catalog Number Explanation	16
	Linear Motor Components	17
	Design Consideration	18
	Motor Air Gap	18
	Bumpers, Shock Absorbers, or End Stops	18
	Linear Encoder	19
	Carriage/Heat Sink.	19
	Maintenance	19
	Motor Storage	19
	Chapter 3	
Installing the LDC-Series Linear Motor	Introduction	21
	Unpacking and Inspection.	21
	Installing Linear Motor Components.	22
	Required Tools	22
	Mount a Single Coil and Multiple Magnet Tracks.	22
	Mount a Single Coil with a Single Magnet Track	27
	Chapter 4	
LDC-Series Linear Motor Connector Data	Introduction	31
	Linear Motor Coil Connectors	31
	Power Connector.	31
	PTC Thermistor Connector	32
	Hall Effect Module Connectors.	32
	Feedback Connector	32
	PTC Thermistor Connector	33
	Encoder Connector	33

Wiring the LDC-Series Linear Motor	<p>Chapter 5</p> <p>Introduction 35</p> <p>Connect the Linear Motor Coil 35</p> <p>Signal and Wire Definitions for Flying Lead Components . . . 37</p> <p style="padding-left: 20px;">Linear Motor Coil 37</p> <p style="padding-left: 20px;">Hall Effect Module 38</p> <p>Making Your Own Extension Cables 38</p> <p>Mounting and Wiring Two Identical Coils in Tandem 39</p> <p style="padding-left: 20px;">Cables Exit to the Right 39</p> <p style="padding-left: 20px;">Cables Exit in the Center 40</p> <p style="padding-left: 20px;">Cables Exit on Opposite Ends 41</p>
Configure and Start Up the LDC-Series Linear Motor	<p>Chapter 6</p> <p>Introduction 43</p> <p>Before You Begin 43</p> <p style="padding-left: 20px;">Motor Direction Defined 43</p> <p>What You Need 44</p> <p>Required Files 44</p> <p>Follow These Steps 45</p> <p>Update Linear Motor Database 45</p> <p>Set Up the Connection to Kinetix 6000 or</p> <p style="padding-left: 20px;">Kinetix 2000 Drive 46</p> <p>Set Up the Connection to an Ultra3000 Drive 51</p> <p>Verify Motor Encoder Direction 53</p> <p>Verify Motor Encoder Resolution 54</p> <p>Verify Linear Motor Wiring and Function 54</p> <p>Additional Adjustments for Cooling Plate Option 58</p>
Specifications and Dimensions	<p>Appendix A</p> <p>Introduction 59</p> <p>Performance Specifications 60</p> <p style="padding-left: 20px;">Common Performance Specifications 60</p> <p style="padding-left: 20px;">Performance Specifications 61</p> <p>General Specifications 66</p> <p style="padding-left: 20px;">Weight Specification 66</p> <p style="padding-left: 20px;">Carriage Weight and Heat Sink Area Requirements 67</p> <p style="padding-left: 20px;">Cooling Plate Flow Rate Specifications 68</p> <p style="padding-left: 20px;">Environmental Specifications 68</p> <p style="padding-left: 20px;">Certifications 68</p> <p>Product Dimensions 69</p> <p style="padding-left: 20px;">Motor Coil Dimensions 70</p> <p style="padding-left: 20px;">Magnet Track Dimensions 74</p> <p style="padding-left: 20px;">Cooling Plate Dimensions 75</p>

Interconnect Diagrams	Appendix B	
	Introduction	77
	Wiring Examples.	77
Sin/Cos Linear Encoder and Kinetix 6000 Drives	Appendix C	
	Introduction	87
	Kinetix 6000 Drive Feedback Connection.	87
	Encoder Counting Direction	88
	Set Up the Axis Properties.	88
	Index	

About This Publication

This manual provides detailed installation instructions for mounting, wiring, and maintaining your LDC-Series Iron Core Linear Servo Motors.

Who Should Use This Manual

This manual is intended for engineers or technicians directly involved in the installation, wiring, and maintenance of LDC-Series iron core linear motors.

If you do not have a basic understanding of linear motors, contact your local Rockwell Automation sales representative for information on available training courses before using this product.

Additional Resources

The following documents contain additional information concerning related Rockwell Automation products.

Resource	Description
Kinetix 2000 Multi-axis Servo Drive User Manual, publication 2093-UM001	How to install, setup, and troubleshoot a Kinetix 2000 drive
Kinetix 6000 Multi-axis Servo Drive User Manual, publication 2094-UM001	How to install, setup, and troubleshoot a Kinetix 6000 drive
Ultra3000 Digital Servo Drives Installation Manual, publication 2098-IN003	How to install, setup, and troubleshoot an Ultra3000 drive
Ultra3000 Digital Servo Drives Integration Manual, publication 2098-IN005	
Ultra3000 Digital Servo Drives User Manual, publication 2098-UM001	Instruction on configuring Ultra3000 and Ultra500 drives, creating and configuring project, source, and header files and creating and running programs
Motion Analyzer CD, download at http://ab.com/e-tools .	Drive and motor sizing with application analysis software
Motion Modules in Logix5000 Control Systems User Manual, publication LOGIX-UM002	Information on configuring and troubleshooting your ControlLogix and CompactLogix SERCOS interface modules, and using the home to torque-level sequence
System Design for Control of Electrical Noise Reference Manual, publication GMC-RM001	Information, examples, and techniques designed to minimize system failures caused by electrical noise
Kinetix Motion Control Selection Guide, publication GMC-SG001	Information about Kinetix products
Safety Guidelines for the Application, Installation, and Maintenance of Solid State Controls, publication SGI-IN001	Characteristics, application, installation, and maintenance of solid state controls
Allen-Bradley Industrial Automation Glossary, publication AG-7.1	A glossary of industrial automation terms and abbreviations
Rockwell Automation Product Certification Website, publication available at http://www.ab.com	For declarations of conformity (DoC) currently available from Rockwell Automation
National Electrical Code. Published by the National Fire Protection Association of Boston, MA.	An article on wire sizes and types for grounding electrical equipment

You can view or download publications at <http://literature.rockwellautomation.com>. To order paper copies of technical documentation, contact your local Rockwell Automation distributor or sales representative.

Notes:

Safety Considerations

Introduction

This chapter describes the safety issues encountered while using a linear motor and the precautions you can take to minimize risk. Potential hazards discussed here are identified by labels affixed to the device.

Topic	Page
Labels	9
High Energy Magnets	10
Vertical or Incline Installation	12
Operational Guidelines	13



Labels

Here you will find the safety and identification labels affixed to your linear motor components. To prevent injury and damage to the linear motor, review the safety label and its details and location before using the linear motor.

Safety Label

Title	Location	Label	Details
Magnetic Field Danger	A		<p>The Magnetic Fields label identifies non-ionizing radiation found in the magnet tracks. Magnet tracks are constructed with strong magnets. Strong magnets can disrupt the functionality of automatic implantable cardioverter defibrillators (AICD); people with a pacemaker should not work near the magnet tracks. Maintenance personnel working near the magnet tracks should avoid the use of metallic tools and secure items such as badge clip and other personal effects that could be attracted by the strong magnets. Strong magnets can erase magnetic media. Never let credit cards or electronic media contact or come near the magnet tracks.</p>

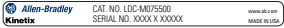
Identification Labels

Title	Location	Label	Details
Coil Name Plate	B		This name plate shows the coil catalog number, serial number operating voltage and frequency
Magnet Track Name Plate	C		This name plate shows the magnet track catalog number, serial number.
RoHS Compliant	D		LDC-Series linear motor components are RoHS compliant.

Label Locations for LDC-Series Linear Motor

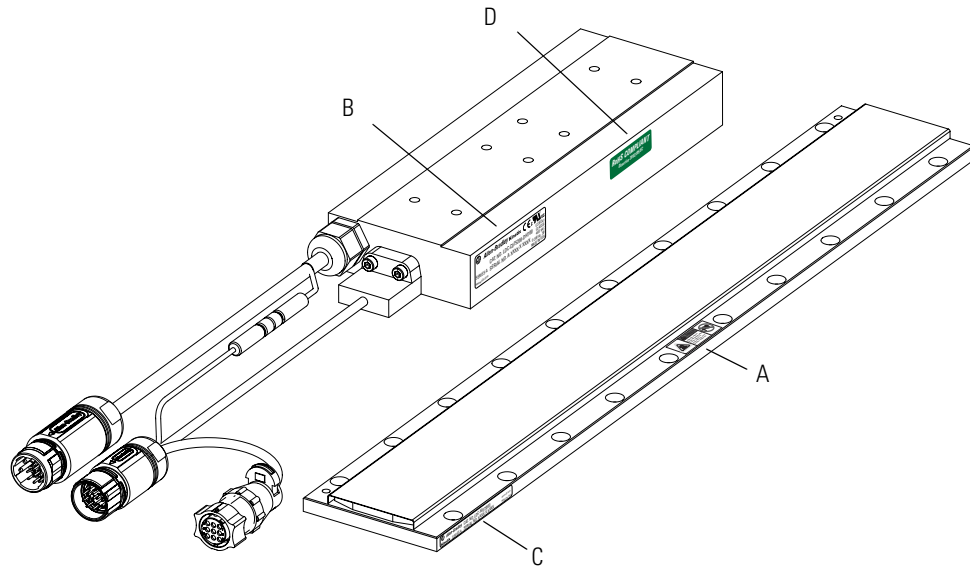

High Energy Magnets

Linear motor magnet tracks contain high energy magnets that attract ferrous metals from a considerable distance. Precautions must be taken while unpacking, handling, and shipping by air.

Unpacking and Handling

Unpack magnet tracks one at a time. Repack magnet tracks after inspection and before it is stocked or staged for installation. Leave protective wrapping, cardboard and flux containment plates in place

until magnet track is installed. Clear the inspection and repacking area of any ferrous metals that will be attracted to or attract the magnetic assembly. If magnet tracks must be unpacked at the same time maintain a distance of 1.5 m (5 ft) between assemblies.

Air Freight Restrictions

When air freighting linear motor special preparations and precautions must be taken. The following information outlines the basic requirements at the publication date of this document. However, regulations are subject to change and additional area or carrier restrictions may be imposed. Always check with your carrier or logistics specialist regarding current local, regional, and national transportation requirements when shipping this product.

Linear motor magnet track contain magnetized material, as classified by International Air Transport Association (IATA) Dangerous Goods Regulations. An IATA trained individual must be involved when shipping this product via domestic or international air freight. Packing Instruction 902 provides information regarding the preparation of this product for air transportation. Follow these regulations for general marking and labeling requirements, the application of specific Magnetized Material Handling Labels, and instructions for preparing the Shipper's Declaration for Dangerous Goods.

As a minimum, refer to the following IATA Dangerous Goods Regulations:

- Subsection 1.5: Training
- Subsection 3.9.2.2: Classification as Magnetized Material
- Subsection 4.2: Identification as UN 2807, Magnetized Material, Class 9, Packing Instruction 902
- Subsection 7.1.5: Marking
- Subsection 7.2: Labeling
- Subsection 7.4.1: Magnetized Material Label
- Section 8: Shipper's Declaration for Dangerous Goods

When shipped via ground in the United States, these products are **not** considered a U.S. D.O.T. Hazardous Material and standard shipping procedures apply.

Vertical or Incline Installation

A linear motor driven system mounted vertically or on an incline will not maintain position when the power is removed. Under the influence of gravity the motion platform and its payload will fall to the low end of travel. Design engineers should allow for this by designing in controlled power down circuits or mechanical controls to prevent the linear motor driven system and its payload from being damaged when the power fails.

ATTENTION



Linear motors are capable of high accelerations, sudden and fast motion. Rockwell Automation is not responsible for misuse, or improper implementation of this equipment.

ATTENTION



Linear motor driven systems must have end of travel bumpers. They must be designed to take a large impact from uncontrolled motion. The payload must be secured to the system such that it will not shear off in the event of an impact in excess of the bumper ratings.

ATTENTION



The Hall effect module contains an electrostatic discharge (ESD) sensitive device. You are required to follow static-control precautions when you install, test, service, or repair this assembly. If you do not follow ESD control precautions, components can be damaged. If you are not familiar with static control precautions, refer to Guarding Against Electrostatic Damage, publication [8000-4.5.2](#), or any other applicable ESD awareness handbook.

BURN HAZARD



When the linear motors are running at their maximum rating the temperature of attached heat sink can reach 100 °C (212 °F).

SHOCK HAZARD



An assembled linear motor will generate power if the coil or magnet track is moved. Un-terminated power cables present an electrical shock hazard. Never handle flying leads or touch power pins while moving the motor.

Operational Guidelines

Please read and follow the guidelines shown here to safely operate the linear motor created from the these linear motor components.

ATTENTION

Observe maximum safe speed. Linear motors are capable of very high forces, accelerations, and speeds. The maximum obtainable acceleration and speed is based on the drive output (bus voltage and current settings). The allowable maximum speed is application specific and partly based on the linear motion mechanics supplied by others.

ATTENTION

Moving parts can cause injury. Before operating the linear motor, make sure all components are secure and magnet mounting hardware is below magnet surface. Remove all unused parts from the motor travel assembly to prevent them from jamming in the motor air gap and damaging the coil or flying off and causing bodily injury.

IMPORTANT

You are responsible for making sure the servo control system safely controls the linear motor with regards to maximum safe force, acceleration, and speed, including runaway conditions.

A runaway condition can be caused by incorrect motor, hall effect, and position feedback wiring resulting in violent uncontrolled motion.

ATTENTION

Keep away from the line of motor travel at all times. Always have bumpers in place and securely fastened before applying power to your linear motor.

ATTENTION

High Voltage can kill. Do not operate with exposed wires. Do not go near electrically live parts.

WARNING



Large Position Error Tolerances, such as those calculated by the Auto Tune function in RSLogix 5000 programming software, or when configuring a new axis with RSLogix 5000 software, can lead to undetected and repetitive high energy impacts against axis end stops if proper precautions are not in place. These tolerances can also lead to undetected and repetitive high energy impacts against unexpected obstructions. Such impacts can lead to equipment damage and/or serious injury.

To identify the safety concerns that you have with default Position Error Tolerance or after an Auto-Tune Function go to the [Rockwell Automation Knowledgebase](#). Click on Find Technical Support Answers and search for Answer Id 55937.

Start

Introduction

Use this chapter to become familiar with the linear motor components, their maintenance needs, and their configuration.

Topic	Page
Catalog Number Explanation	16
Linear Motor Components	17
Design Consideration	18
Maintenance	19
Motor Storage	19

Catalog Number Explanation

An iron core linear motor is comprised of a coil and a magnet track. The following keys show the catalog definition for the LDC-Series linear motors.

LDC - x xxx xxx - x x x x x

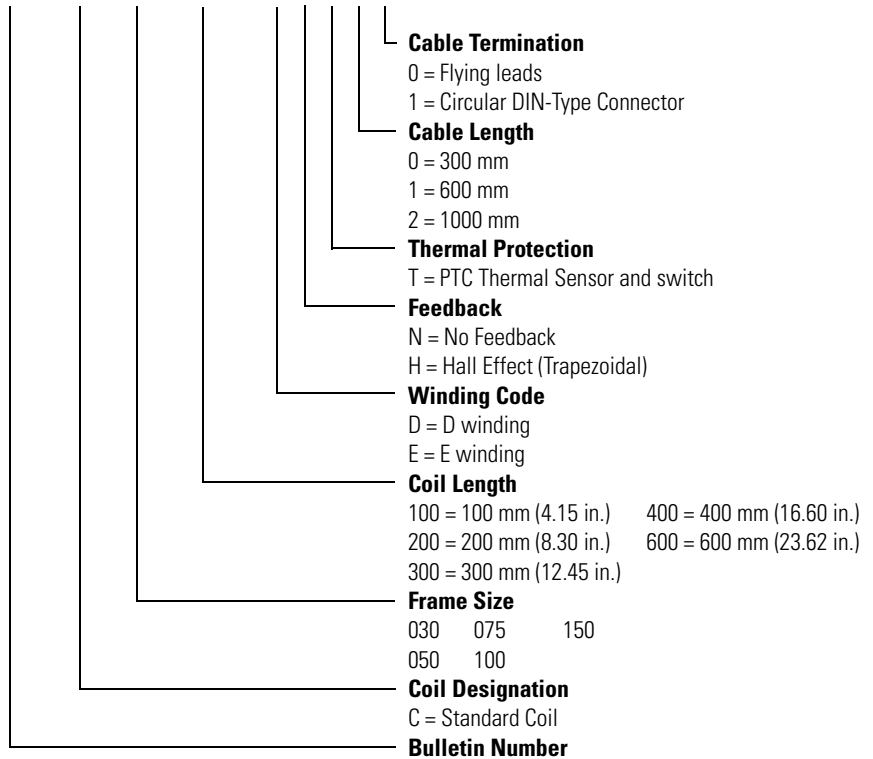

LDC - x xxx xxx

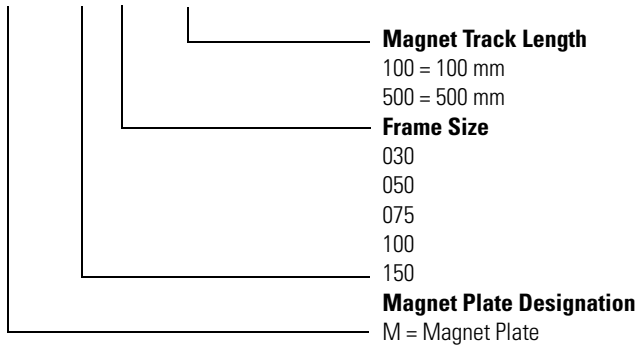

LDC - xxx - xxx - CP

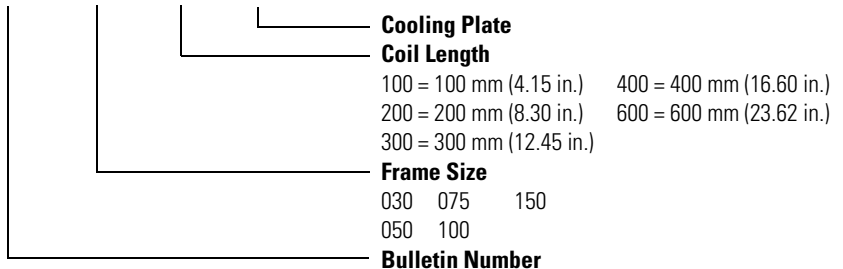

Linear Motor Components

Use the diagrams and descriptions to identify the unique components of the linear motor.

Components of Iron Core Motor Coil and Magnet Track

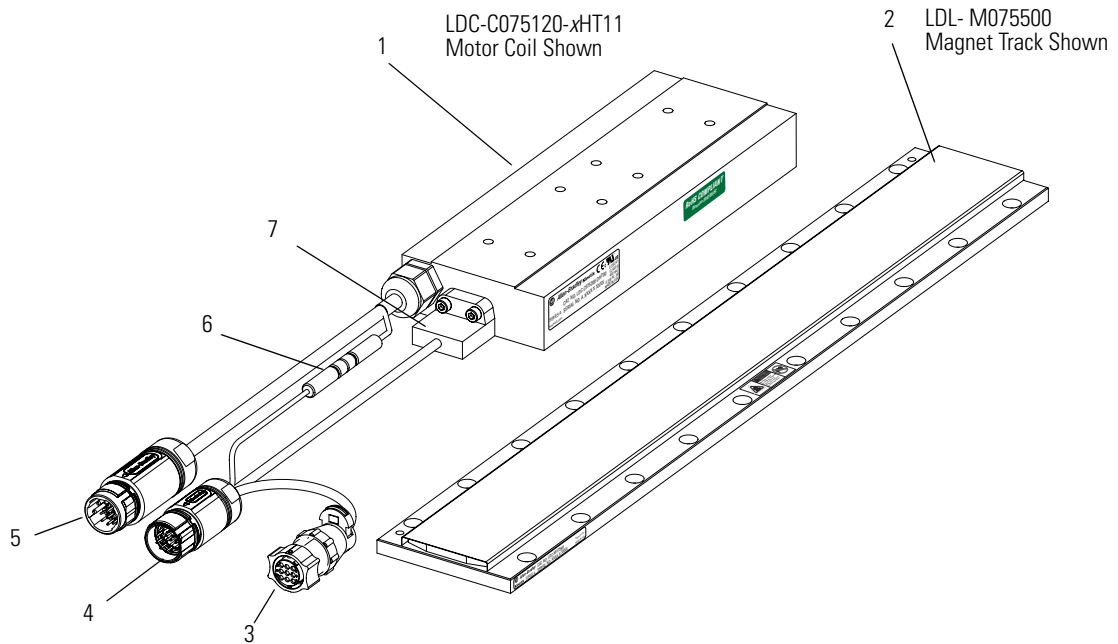

Component Number	Component	Description
1	Iron core motor coil	Copper coils contained in an epoxy form. When powered, the coil interacts with the magnet track.
2	Magnet track	High powered static magnets create the flux field the powered coil interacts with.
3	Encoder connector	Connect your encoder here using connector kit, catalog number LDC-ENC-CNCT.
4	Feedback connector	Connect to your drive feedback using either catalog number 2090-CFBM4DF-CDAFxx (for moving coil) or 2090-XXNFMF-Sxx (for moving magnet).
5	Power connector	Connect to your drive power using either catalog number 2090-CPWM4DF-xxAFxx (for moving coil) or 2090-XXNPMF-xxSxx (for moving magnet).
6	Thermistor connector	Connects the PTC thermistor signal to the feedback connector.
7	Hall effect module	This module provides input signals for commutation start-up. Replacement catalog numbers for the Hall effect module are LDC-HALL-C for LDC-xxxxxx-xHT11 and LDC-HALL-F for LDC-xxxxxx-xHT20.

Design Consideration

The information provided here is critical to using linear motor components. Design your system to comply with the following points to run safe and successfully.

Motor Air Gap

Maintaining the air gap is critical to proper installation and operation of the linear motor components. Use the coil, magnet and cooling plate drawings in [Appendix A](#) to calculate the installation envelope dimension. By maintaining installation envelope dimension in your design the vertical air gap requirement will be met. The following diagram shows the critical dimensions.

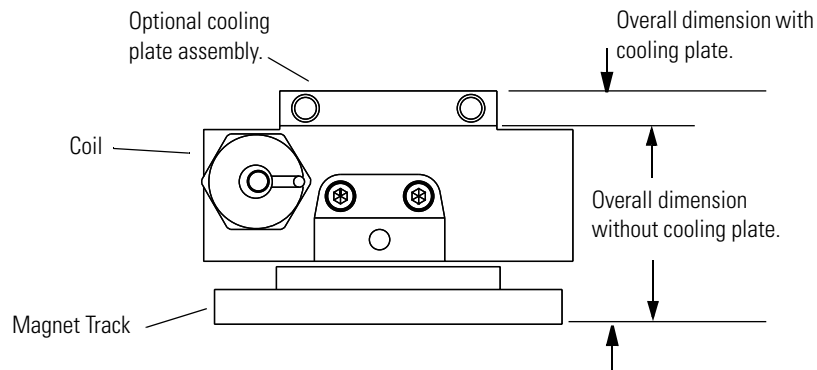

Bumpers, Shock Absorbers, or End Stops

Always include in your design a mechanical stop at the ends of travel. Design them such that they can prevent the moving mass from leaving its travel limits. Take into consideration the maximum speed and inertia of your moving mass when designing your mechanical stops. The following diagram shows a minimal system with mechanical stops.

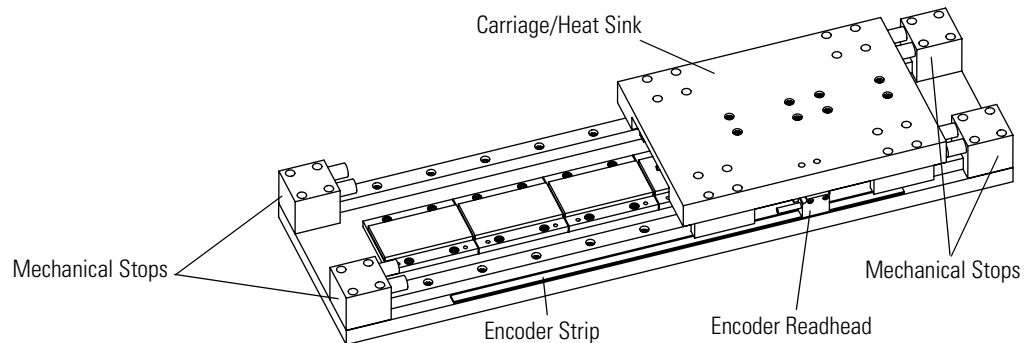

Linear Encoder

Your linear motor components needs to be integrated with a linear encoder purchased from a third party.

Carriage/Heat Sink

The linear motor coil requires a heat sink to maintain performance. The heat sink requires a minimal mass and surface area as shown on [page 67](#). It can as so serve as the carriage in moving coil system or be designed into the base in moving magnet system.

Maintenance

Linear motors require no maintenance when operated in a relatively clean environments. For operation in harsh and dirty environments, minimal cleaning is recommended every 6 months.

Clean the metallic debris and other contaminants from the air gap. Use a strip of masking tape to effectively remove the metal debris. Apply a strip of tape on the magnet track and then remove it. Keeping the magnet track clean will prevent witness marks. Witness marks are caused by metal debris being dragged across the surface of the stainless steel by the magnet field of the moving coil. Witness marks have no effect on the performance of the motor.

Motor Storage

Motor storage area should be clean, dry, vibration free, and have a relatively constant temperature. If a motor is stored on equipment, it should be protected from the weather. All motor surfaces subject to corrosion should be protected by applying a corrosion resistant coating.

Notes:

Installing the LDC-Series Linear Motor

Introduction

In this section you will unpack, inspect and install a your linear motor components creating your own linear motor.

Topic	Page
Unpacking and Inspection	21
Installing Linear Motor Components	22

Unpacking and Inspection

Handle magnet tracks carefully please read the following.

ATTENTION



Linear motors contain powerful permanent magnets which require extreme caution during handling. When handling multiple magnet tracks do not allow the tracks to come in contact with each other. Do not disassemble the magnet tracks. The forces between tracks are very powerful and can cause bodily injury. Persons with pacemakers or Automatic Implantable Cardiac Defibrillator (AICD) should maintain a minimum distance of 0.33 m (1ft) from magnet assemblies. Additionally, unless absolutely unavoidable, a minimum distance of 1.5 m (5 ft) must be maintained between magnet assemblies and other magnetic/ferrous composite materials. Use only non-metallic instrumentation when verifying assembly dimension prior to installation.

Inspect motor components and verify they are damage free. Any damage or suspected damage should be immediately documented. Claims for damage due to shipment are usually made against the transportation company. Contact Rockwell Automation for further advise.

- Compare the purchase order with the packing slip.
- Check the quantity of magnet tracks received matches your job requirements.
- Identify the options that came with your linear motor.
- Inspect the assemblies and confirm the presence of specified options.

Installing Linear Motor Components

Use one of the following procedures to install the magnet track(s) and the motor coil.

Required Tools

- Aluminum straight edge
- Non-magnetic M5 hex wrench
- Magnet track alignment tool.

IMPORTANT

The alignment tool is shipped attached to the cables next to the Hall effect module. Remove before operating the linear motor.

TIP

Non-magnetic tools and hardware made of beryllium copper, 300 series stainless steel, and others should be used. If not available, proceed carefully since magnetic and ferrous items will be attracted to the magnet track.

Mount a Single Coil and Multiple Magnet Tracks

Follow these steps to install a single coil with multiple magnet tracks.

ATTENTION

To avoid damage due to the magnetic attraction between the magnet tracks, maintain a minimum distance of 1.5 m (5 ft) between the magnet tracks that are being installed and the magnet tracks awaiting installation. Keep the protective cardboard and the metal plate in place until the installation is complete.

ATTENTION

Never attempt to place the coil assembly directly on the magnet plates. Strong magnetic attraction will cause uncontrolled movement causing a pinch hazard and possible damage to the components.

1. Clear the magnet track mounting surface of foreign material. If necessary stone the mounting surface, acetone or methanol may be applied as cleaning agent.

IMPORTANT

Do not use abrasives to clean the surface.

2. Verify the flatness of the surface to which the magnet track is to be mounted.

Total Indicator Reading (TIR) is 0.127 mm (.005 in.) per 300 mm (12.0 in.). TIR or runout correlates to the overall flatness requirement of the surface.

3. Verify the dimension of the opening for the magnet track, coil, and cooling plate if used.
4. Remove all burrs and clean the motor coil mounting surface.
5. Position the carriage toward the end of travel where you want the cable to exit.
6. Install the motor under the carriage, using M5 x 0.8 bolts that extend through the slide by at least 12 mm (0.5 in.), but no more than 20 mm (0.7 in.).

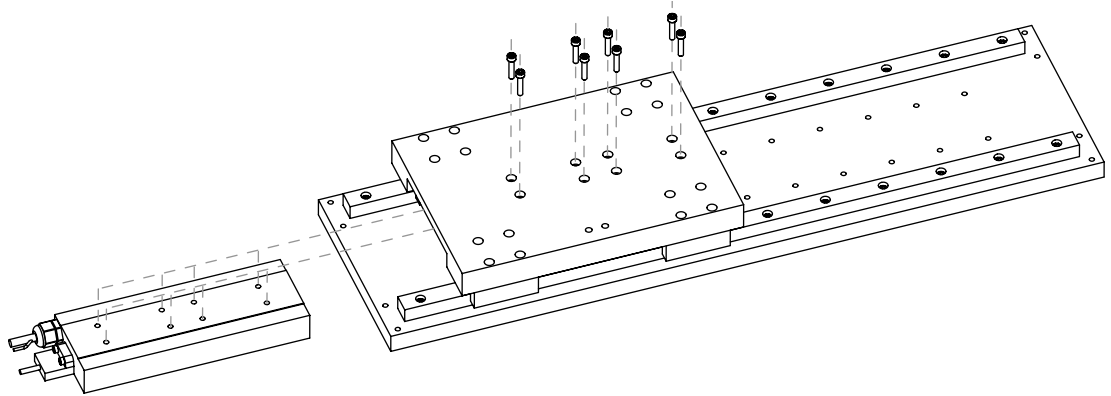

7. Tighten the screws but do not torque.
8. On the opposite end of the base, install the first magnet track using M5 x 0.8 x 16 mm Socket Head Captive Screw (SHCS). Do not tighten screws.

IMPORTANT

Use non-magnetic tools and hardware such as beryllium copper, 300 series stainless steel. If not available proceed with care since ferrous items will be attracted to the magnet tracks.

9. Install additional magnet tracks.

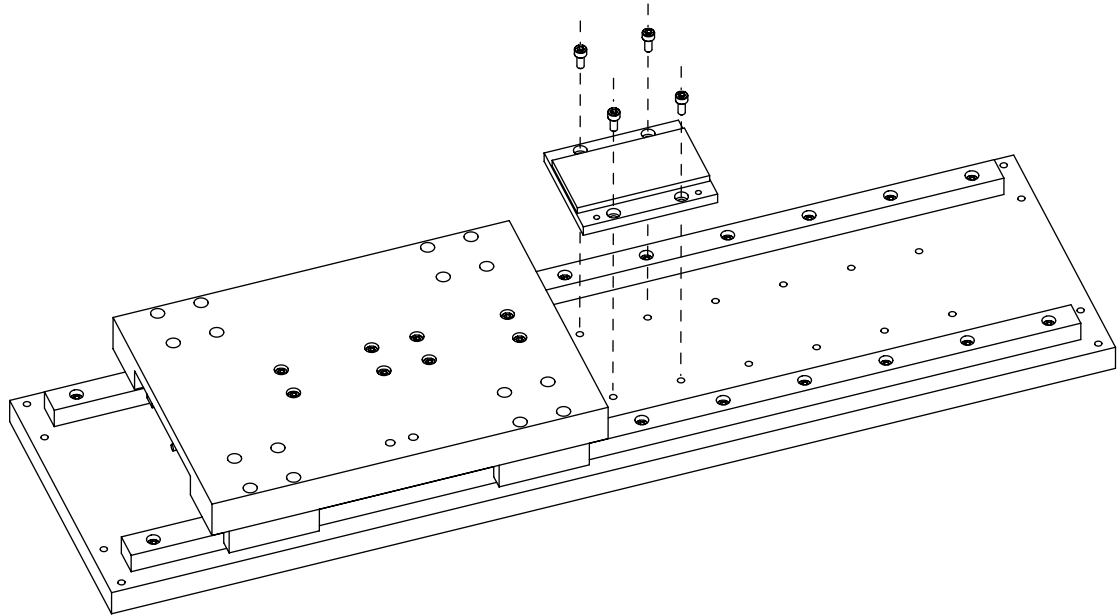

10. Place each magnet track on the base and slide towards the previously install magnet track.

For correct magnetic polarity the alignment holes should all be on the same side.

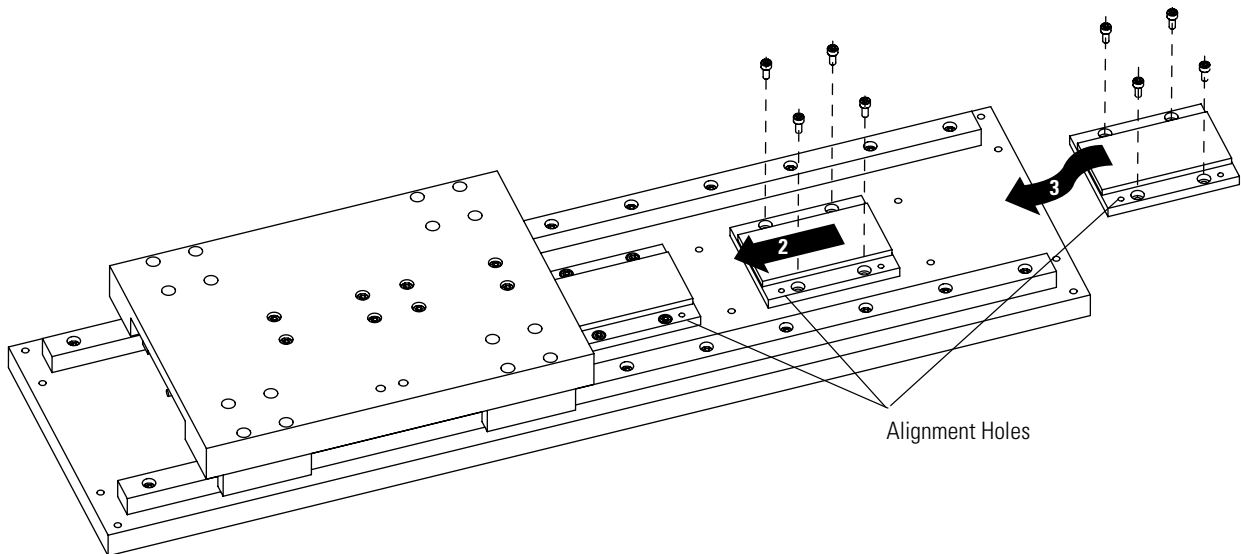

11. Move the carriage with motor coil installed over the installed magnet tracks.

There may be some resistance while moving onto the tracks, this is normal.

12. Measure the gap between the motor coil and magnet track using plastic shim stock. The gap should be 0.79 mm (0.031 in.) to 1.70 mm (0.067 in.).

If gap is too large, add a brass or a stainless steel shim between motor coil and carriage. If gap is too small, machine the slide or place shims under the bearing pucks.

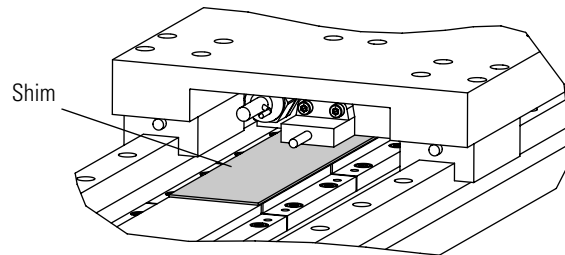

13. Install the remaining magnet tracks in order shown.

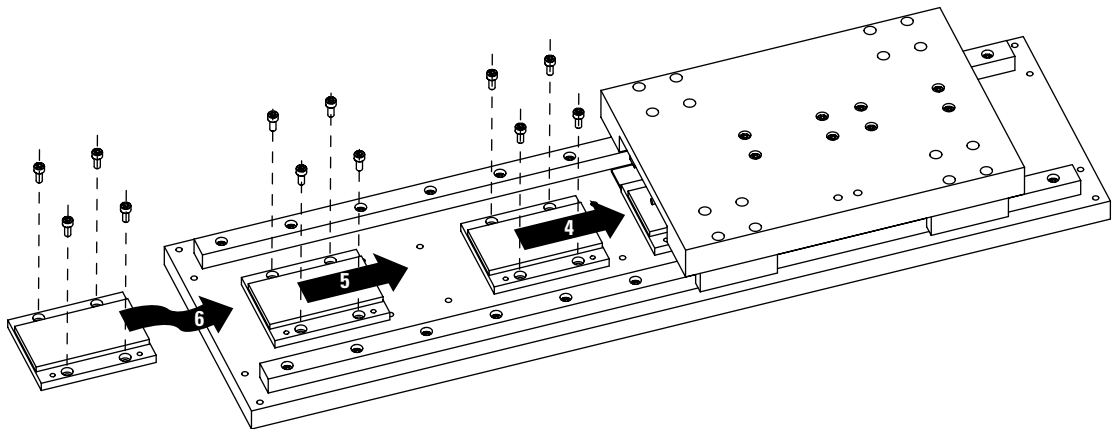

14. Slightly loosen the mounting screws on the exposed magnet tracks. Do not loosen the magnet tracks that are covered by the motor coil.

15. Align the magnet tracks with an aluminum straight edge, and the supplied alignment tool.

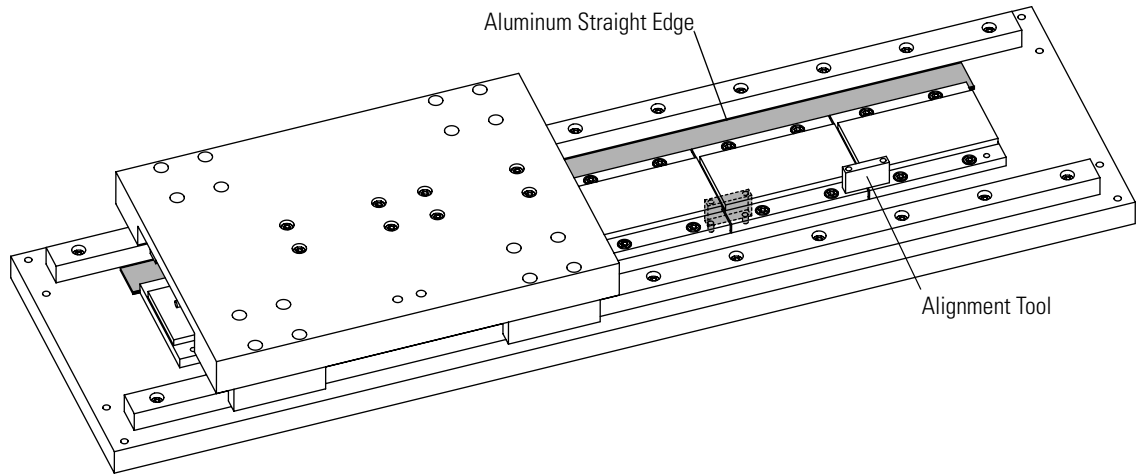

16. Place the alignment tool in the holes on each of the magnet tracks. Align the edges of the magnet tracks with the aluminum straight edge and tighten the bolts. Position the slide over the complete sections and continue aligning the remainder of the magnet tracks. .

TIP

If space limitation prevents the use of an aluminum straight edge. Place a 0.020 mm (0.0008 in.) plastic shim between the magnet tracks, tighten the bolts, and then remove the shim.

17. Torque all screws to value listed in the table. Secure assemblies in place using all mounting holes.

SHCS	SHCS Torque	
	Black Oxide Steel N•m (lb•ft)	Stainless Steel N•m (lb•ft)
M5	9.5 (7.0)	6.36 (4.7)

ATTENTION



Remove alignment tool and make certain all magnet track mounting hardware is flush or below magnet surface to prevent damage to the coil.

Mount a Single Coil with a Single Magnet Track

Follow these steps to install a single coil with single magnet track.

1. Install the magnet track using M5 x 0.8 x 16 mm SHCS.

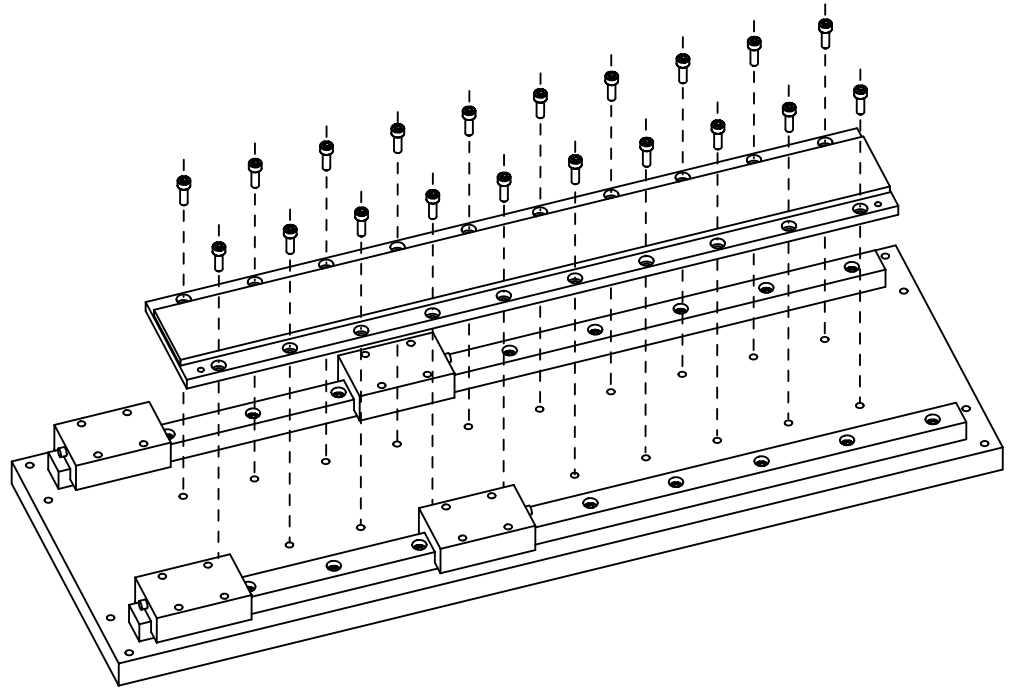

2. Remove any burrs and clean the motor coil mounting surface.
3. Install the motor coil under the carriage, using M5 x 0.8 screws that extend through the slide by at least 12 mm (0.5 in.), but no more than 20 mm (0.7 in.).

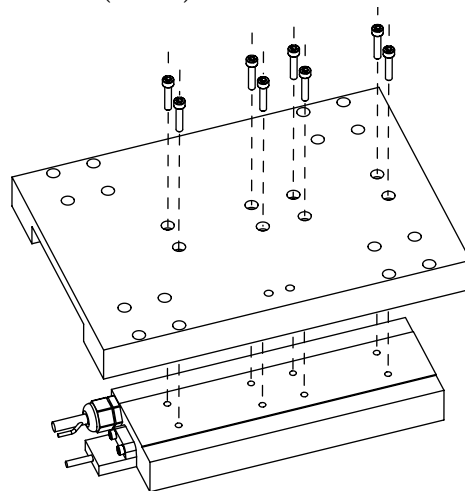

4. Tighten screws but do not torque.
5. Slide carriage assembly on to the bearing pucks.

There will be resistance from magnetic forces while moving onto the bearing pucks, this is normal.

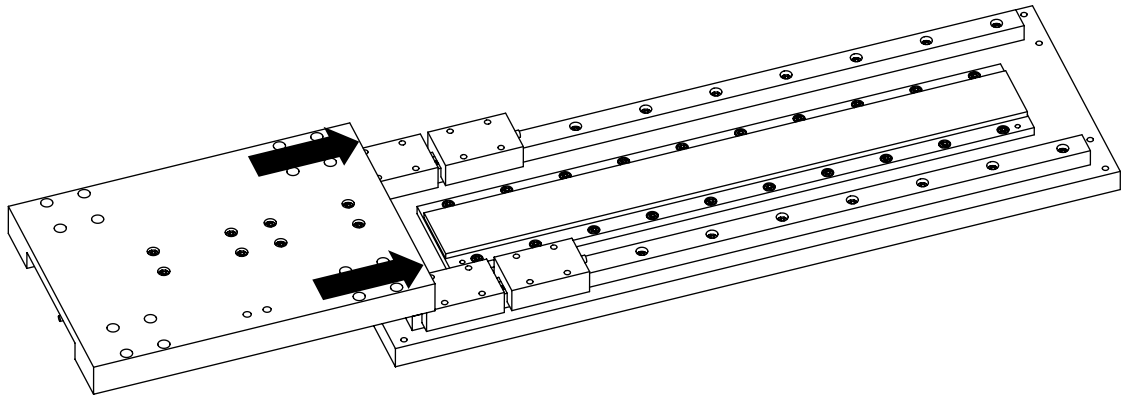

6. Attach the carriage assembly to the bearing pucks.

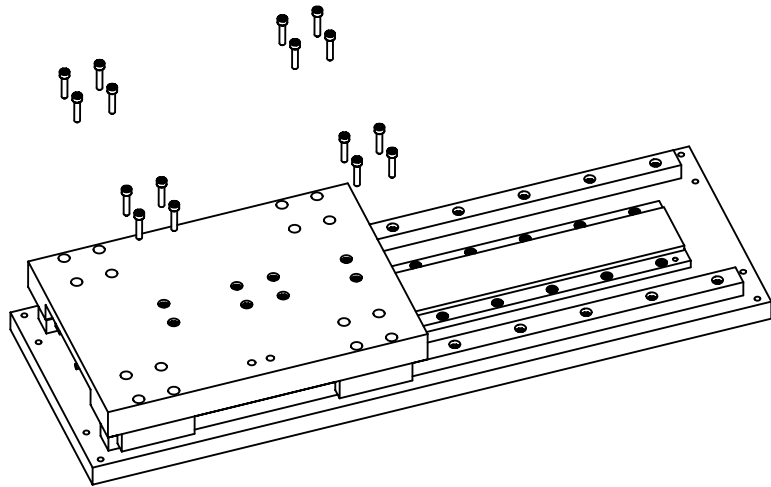

7. Measure the gap between the motor and magnet using plastic shim stock. The gap should be 0.79 mm (0.031 in.) to 1.70 mm (0.067 in.).

If gap is too large, add brass or stainless steel shim between motor and slide. If gap is too small, machine the slide or place shims under the bearing pucks.

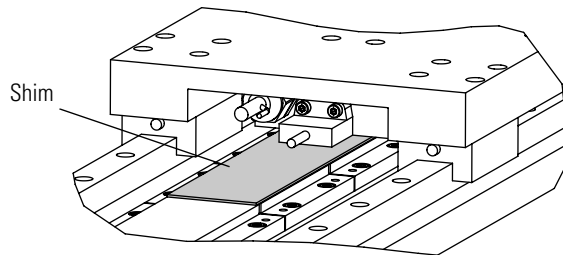

8. Torque all screws to value listed in the table. Secure assemblies in place using all mounting holes.

SHCS	SHCS Torque	
	Black Oxide Steel N•m (lb•ft)	Stainless Steel N•m (lb•ft)
M5	9.5 (7.0)	6.36 (4.7)

ATTENTION



Remove alignment tool and make certain all magnet track mounting hardware is flush or below magnet surface to prevent damage to the coil.

Notes:

LDC-Series Linear Motor Connector Data

Introduction

This chapter provides power, thermistor, and Hall effect cable connector information for the linear motor coil and Hall effect module.

Topic	Page
Linear Motor Coil Connectors	31
Hall Effect Module Connectors	32

Linear Motor Coil Connectors

There are two connectors on the linear motor coil, catalog number LDC-xxxxxxx-xxT11, the power and the Positive Temperature Coefficient (PTC) thermistor.

Power Connector

The following tables identify the power signals for DIN style circular connector.#

Pin	Color	Signal
A	Red	U (A) Phase
B	White	V (B) Phase
C	Black	W (C) Phase
D	Green/Yellow	Ground
Case	Shield	Cable Shield and GND

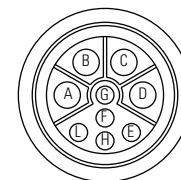

Intercontec P/N BKUA090NN00420220000
Mating Connector Kit Allen-Bradley 2090-KPBM4-12AA

ATTENTION



Properly ground the coil as described in this manual and the drive manual.

PTC Thermistor Connector

Pin	Description	Signal
1	Positive Temperature Coefficient (PTC) thermistor +	TS+
3	Positive Temperature Coefficient (PTC) thermistor -	TS-
4	–	Reserved

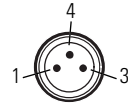

Mates with PTC thermistor connector on Hall effect module.

Hall Effect Module Connectors

The following tables show the pinouts the Hall effect module.

Feedback Connector

Pin	Description	Signal
1	A Quad B TTL (1 V p-p), + A Differential	AM+ (SIN+)
2	A Quad B TTL (1 V p-p), - A Differential	AM- (SIN-)
3	A Quad B TTL (1 V p-p), + B Differential	BM+ (COS+)
4	A Quad B TTL (1 V p-p), - B Differential	BM- (COS+)
5	TTL + Index Mark Differential	IM+
6	TTL - Index Mark Differential	IM-
7	Reserved	–
8		
9	Encoder and Hall Sensor Power	+5V DC
10	Common	Common
11	Reserved	–
12	Common	Common
13	PTC Thermistor	PTC Temp+
14	PTC Thermistor	PTC Temp-
15	TTL - Trapezoidal Hall Commutation	S1
16	TTL - Trapezoidal Hall Commutation	S2
17	TTL - Trapezoidal Hall Commutation	S3
Case	Shield	–

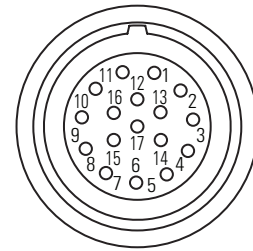

Intercontec P/N AKUA015NN00400220000
Mating Connector Kit Allen-Bradley 2090-KFBM4-CAAA

PTC Thermistor Connector

Pin	Description	Signal
1	Positive Temperature Coefficient (PTC) thermistor +	TS+
4	Reserved	—
3	Positive Temperature Coefficient (PTC) thermistor -	TS-

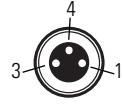

Mates with PTC thermistor connector on linear motor coil.

Encoder Connector

Pin	Description	Signal
1	A Quad B TTL, + A Differential	AM+
2	A Quad B TTL, + B Differential	BM+
3	TTL + Index Mark Differential	IM+
4	A Quad B TTL, - A Differential	AM-
5	A Quad B TTL, - B Differential	BM-
6	TTL - Index Mark Differential	IM-
7	5V DC Return	Common
8	Encoder and Hall Sensor Power	+5V DC
9	Shield Drain	—

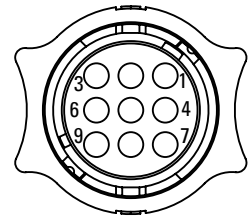

Mating connector available a part of encoder connector kit catalog number LDC-ENC-CNCT.

Notes:

Wiring the LDC-Series Linear Motor

Introduction

This section shows you how to wire your LDC-Series linear motor.

Topic	Page
Connect the Linear Motor Coil	35
Signal and Wire Definitions for Flying Lead Components	37
Making Your Own Extension Cables	38
Mounting and Wiring Two Identical Coils in Tandem	39

Connect the Linear Motor Coil

Use the following procedure to connect your linear motor, catalog number LDC-xxxxxxx-xHT11.

- Using the Encoder Connector Kit, catalog number LDC-ENC-CNCT, and the connector data on [page 33](#), wire your encoder to the connector.

ATTENTION



Be sure that cables are installed and restrained to prevent uneven tension or flexing at the cable connectors. Use Bulk Head Connector Kit, catalog number LDC-BULK-HD, for mounting these connectors.

Excessive and uneven lateral force at the cable connectors may result in the connector's environmental seal opening and closing as the cable flexes.

Failure to observe these safety precautions could result in damage to the motor and its components.

- Connect your encoder to the encoder connector on the Hall effect module.
- Attach the feedback and the power cables.

ATTENTION



Do not connect or disconnect the motor feedback cable or the power cable while power. It may result in unexpected motion or cause damage to the components.

- Align flats on each connector.

- b. Do not apply excessive force when mating the cable and motor connectors. If the connectors do not go together with light hand force, realign and try again.

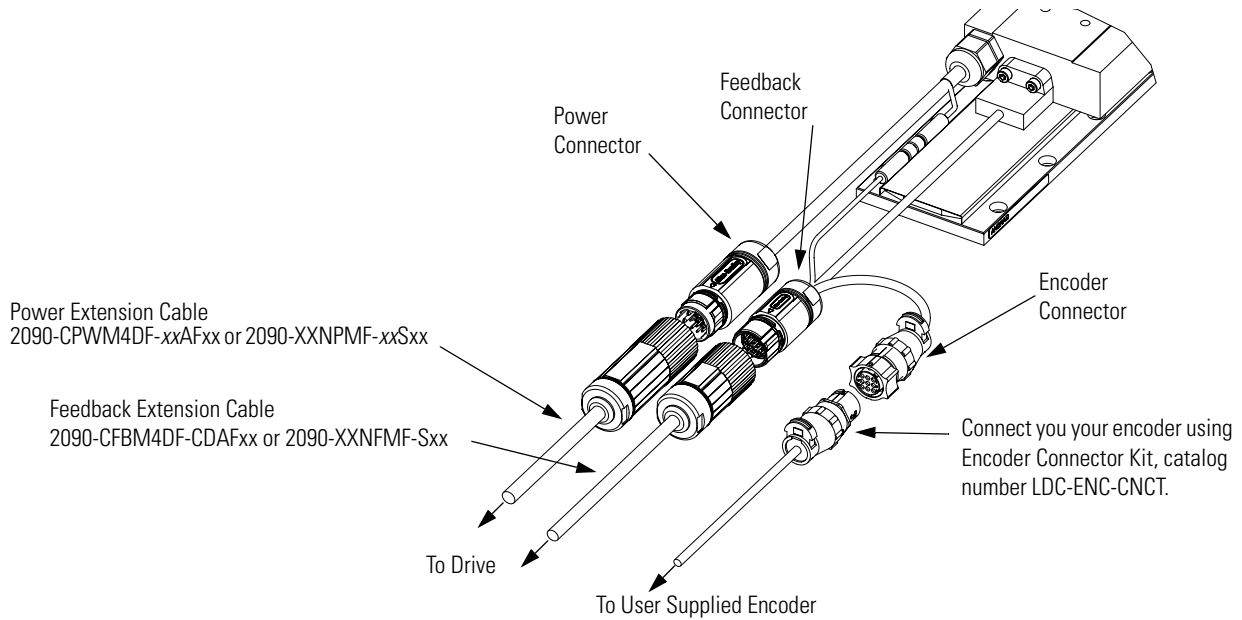

ATTENTION



Be sure that cables are installed and restrained to prevent uneven tension or flexing at the cable connectors. Excessive and uneven lateral force at the cable connectors may result in the connector's environmental seal opening and closing as the cable flexes. Failure to observe these safety precautions could result in damage to the motor or encoder.

- c. Hand tighten the knurled collar with five to six turns to fully seat the connector.

ATTENTION



Keyed connectors must be properly aligned and hand-tightened the recommended number of turns.

Improper alignment is indicated by the need for excessive force, such as the use of tools, to fully seat connectors.

Connectors must be fully tightened for connector seals to be effective.

Failure to observe these safety precautions could result in damage to the motor, cables, and connector components.

Signal and Wire Definitions for Flying Lead Components

For linear motors, catalog numbers LDC-xxxxxxx-xHT20, wire using wiring diagram on [page 80](#). Wire colors and signal types are shown here, for wire gauge information see [page 67](#).

Linear Motor Coil

The following shows the wire color and signals for the linear motor coil power and PTC thermistor cables, catalog number LDC-xxxxxxx-xxT20.

Power Signals

Color	Signal	Comments
Red	Motor Phase U (A)	<ul style="list-style-type: none"> Observe maximum applied voltage specification. Consult drive manual or supplier for specific wiring instructions to the drive. Wiring is phase/commutation sensitive.
White	Motor Phase V (B)	
Black	Motor Phase W (C)	
Green	Motor Ground	<ul style="list-style-type: none"> Terminate per drive manual instructions.
Shield	Cable Shield	<ul style="list-style-type: none"> Shield is not connected to the motor frame.

ATTENTION



Disconnect input power supply before installing or servicing motor.

Motor lead connections can short and cause damage or injury if not well secured and insulated.

Insulate the connections, equal to or better than the insulation on the supply conductors.

Properly ground the motor per selected drive manual.

PTC Thermistor Signals

Color	Description	Signal
Black	Positive Temperature Coefficient (PTC) thermistor +	TS+
Black	Positive Temperature Coefficient (PTC) thermistor -	TS-

Hall Effect Module

This table shows the signal and wire colors for Hall effect module with flying leads, catalog number LDC-HALL-F.

Color	Signal	Signal Spec
Red	+V	5...24V DC Hall supply, 20 mA.
Black	VRTN	Hall effect signal common.
White	S1	–
Blue	S2	
Orange	S3	
Silver braid	Cable shield	Terminate at drive end per drive manual instructions.

Making Your Own Extension Cables

Flying lead coil and Hall effect modules require circular DIN style connectors to interface with Allen-Bradley extension cables. The following connectors kits are available for terminating flying lead coils and Hall effect modules.

Connector Kit Cat. No.	Application
2090-KFBM4-CAAA	Feedback flex extension cable
2090-KPBM4-12AA	Power flex extension cable
2090-KFBE7-CAAA	Feedback non-flex extension cable
2090-KPBE7-12AA	Power non-flex extension cable

The cable length from the coil to drive should be limited to 10 m (32.8 ft). If longer cables are necessary a 1321-3R x - x series line reactor is required. Refer to 1321 Power Conditioning Products Technical Data, publication [1321-TD001](#), to choose a line reactor for applications requiring cable longer than 10 m (32.8 ft).

Mounting and Wiring Two Identical Coils in Tandem

This type of installation requires custom motor database file which is available upon request. Contact Application Engineering at 631.344.6600 to request this file.

The following tables and diagrams show the wiring and spacing for two identical coils mechanically top mounted to the same plate and driven by one amplifier. There are three configurations shown here for mounting motors in tandem: power and encoder cables exiting on the right, the center, and on opposite ends.

ATTENTION



Coils must have identical part numbers. Using mis-matched coils will cause a hazardous condition resulting in damage to the equipment and a possible fire.

Cables Exit to the Right

If mounting coils in tandem, such that the power cables exit both the coils on right side, as shown, use the following table to find the mounting distance and the phase wiring.

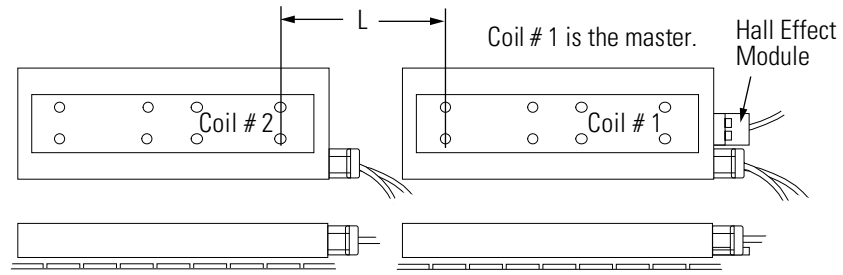

Phase Wiring for Right Exit Power Cables

L mm (in.)	Coil # 1 Master ⁽¹⁾	Coil # 2 Slave ⁽²⁾	Amplifier Phase
133.33 (5.249)	Red	Red	U
	White	White	V
	Black	Black	W

(1) Master has Hall effect module.

(2) Slave has no Hall effect module.

Cables Exit in the Center

If mounting coils in tandem, such that the power cables exit in the center as shown, use the following table to find the mounting distance and the phase wiring.

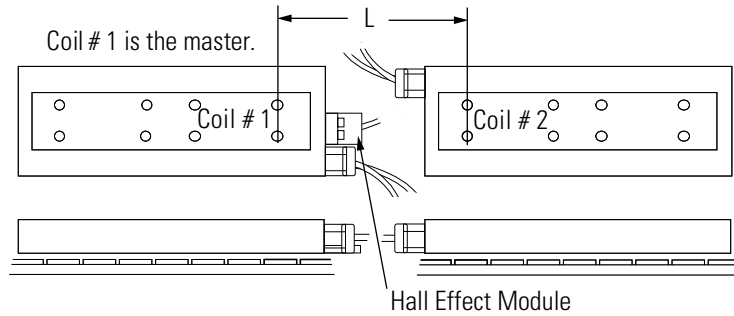

Phase Wiring for Center Exit Power Cables

L mm (in.)	Coil # 1 Master ⁽¹⁾	Coil # 2 Slave ⁽²⁾	Amplifier Phase
133.33 (5.249)	Red	Black	U
	White	White	V
	Black	Red	W

(1) Master has Hall effect module.

(2) Slave has no Hall effect module.

Cables Exit on Opposite Ends

If mounting coils in tandem such that the power cables exit opposite to each other as shown, use the following table to find the mounting distance and the phase wiring.

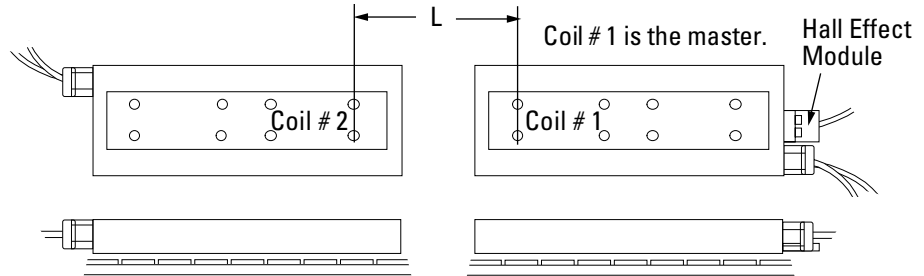

Phase Wiring for Opposite End Exit Power Cables

L mm (in.)	Coil # 1 Master ⁽¹⁾	Coil # 2 Slave ⁽²⁾	Amplifier Phase
100.00 (3.94)	Red	Red	U
	White	Black	V
	Black	White	W
133.33 (5.249)	Red	Black	U
	White	White	V
	Black	Red	W

(1) Master has Hall effect module.

(2) Slave has no Hall effect module.

Notes:

Configure and Start Up the LDC-Series Linear Motor

Introduction

This section covers the setup and connection verification of a linear motor with either Kinetix 6000, Kinetix 2000, or an Ultra3000 drive.

Topic	Pages
Before You Begin	43
What You Need	44
Required Files	44
Follow These Steps	45
Update Linear Motor Database	45
Set Up the Connection to Kinetix 6000 or Kinetix 2000 Drive	46
Set Up the Connection to an Ultra3000 Drive	51
Verify Motor Encoder Direction	53
Verify Motor Encoder Resolution	54
Verify Linear Motor Wiring and Function	54

Before You Begin

This chapter assumes you have wired your linear motor and Allen-Bradley drive as shown on wiring diagrams in [Appendix B](#) starting on [page 77](#).

IMPORTANT

It is important that the motor be wired correctly to get positive motion when commutated.

Please read and understand [Motor Direction Defined](#).

Motor Direction Defined

Positive motion is dependent on encoder orientation, encoder wiring, and coil or magnet track motion.

Most linear encoders are installed with the encoder cable facing the same direction as the coil cable.

Wire the linear encoder such that the position feedback is positive (phase A+ leads phase B+) when the motor is moving in the positive direction.

When the motor power and Hall sensor wiring is connected as shown in wiring diagrams in [Appendix B](#), the positive direction of motion is defined as the motor coil moving toward its power cable. This diagram shows positive motion for both a moving coil and a moving magnet track.

Motor Direction

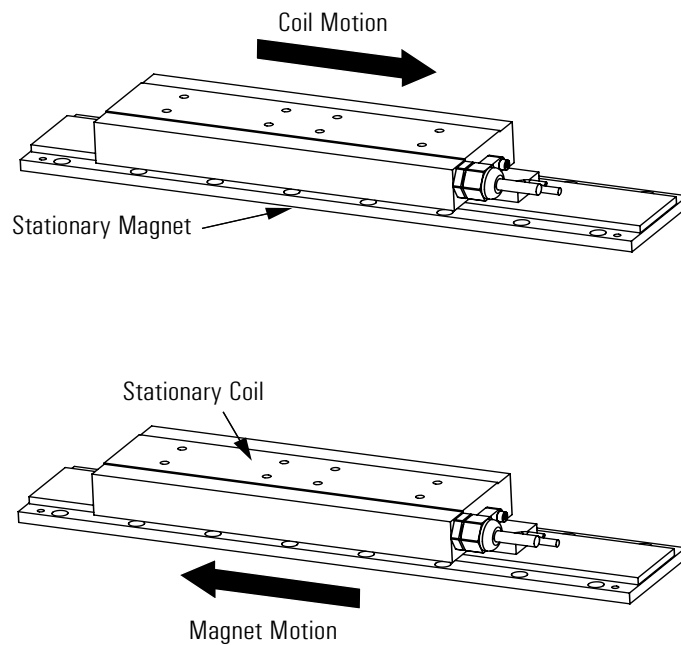

What You Need

You need a computer with RSLogix 5000 software installed and internet access.

Required Files

Firmware revisions and software versions required to support the linear motors include the following:

- RSLogix 5000 software, version 16.00 or later
- Kinetix 2000 or Kinetix 6000 multi-axis drives
 - Firmware revision 1.96 or later

- For RSLogix 5000 software, version 16.xx
use Motion Database file, version 4_17_0 or later
- For RSLogix 5000 software, version 17.xx or later
use Motion Database file, version 5_8_0 or later
- Ultra3000 drives
 - Firmware revision 1.52 or later
 - Motor Database, motor_03_18_09.mdb or later
- Motion Analyzer software, version 4.7 or later

Download these files from <http://support.rockwellautomation.com>. Contact Rockwell Automation Technical Support at 440.646.5800 for assistance.

Follow These Steps

The following flow chart illustrates the required steps.

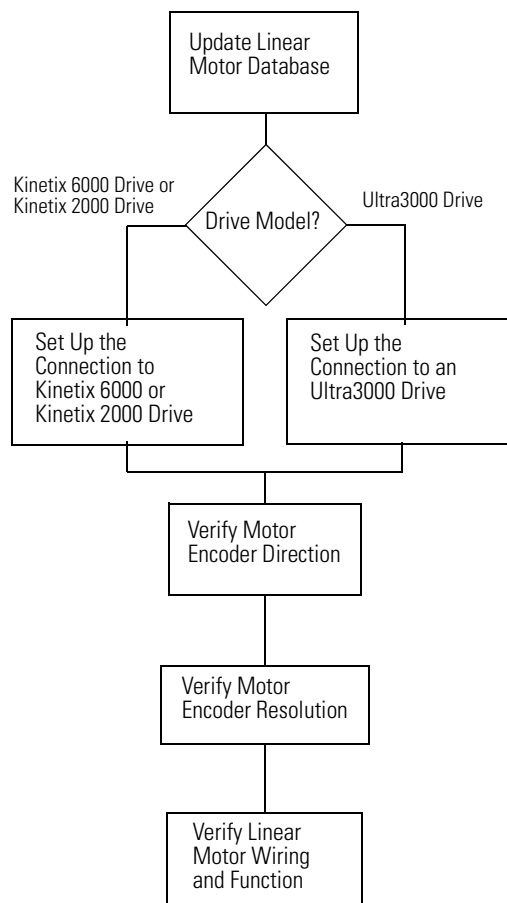

Update Linear Motor Database

Install the current Motion Database, as required, before commissioning your linear motor. See the [Required Files](#) on [page 44](#).

Set Up the Connection to Kinetix 6000 or Kinetix 2000 Drive

This procedure configures the Kinetix 6000 or Kinetix 2000 drive for your linear motor and encoder combination.

For help using RSLogix 5000 software as it applies to setting up your linear motor, refer to [Additional Resources](#) on [page 7](#). This procedure assumes you are familiar with RSLogix 5000 software.

1. Click the Driver/Motor tab.
2. Click Change Catalog and select the appropriate Motor Catalogue Number from the following list. Your catalog number will have a letter append to the end to indicated what drive your are using to power it A = 230V drive and B = 460V drive.

Cat. No.	Cat. No.
LDC-C030100-DHT _{xx} A	LDC-C030100-DHT _{xx} B
LDC-C030200-DHT _{xx} A	LDC-C030200-DHT _{xx} B
LDC-C030200-EHT _{xx} A	LDC-C030200-EHT _{xx} B
LDC-C050100-DHT _{xx} A	LDC-C050100-DHT _{xx} B
LDC-C050200-DHT _{xx} A	LDC-C050200-DHT _{xx} B
LDC-C050200-EHT _{xx} A	LDC-C050200-EHT _{xx} B
LDC-C050300-DHT _{xx} A	LDC-C050300-DHT _{xx} B
LDC-C050300-EHT _{xx} A	LDC-C050300-EHT _{xx} B
LDC-C075200-DHT _{xx} A	LDC-C075200-DHT _{xx} B
LDC-C075200-EHT _{xx} A	LDC-C075200-EHT _{xx} B
LDC-C075300-DHT _{xx} A	LDC-C075300-DHT _{xx} B
LDC-C075300-EHT _{xx} A	LDC-C075300-EHT _{xx} B
LDC-C075400-DHT _{xx} A	LDC-C075400-DHT _{xx} B
LDC-C075400-EHT _{xx} A	LDC-C075400-EHT _{xx} B
LDC-C100300-DHT _{xx} A	LDC-C100300-DHT _{xx} B
LDC-C100300-EHT _{xx} A	LDC-C100300-EHT _{xx} B
LDC-C100400-DHT _{xx} A	LDC-C100400-DHT _{xx} B
LDC-C100400-EHT _{xx} A	LDC-C100400-EHT _{xx} B
LDC-C100600-DHT _{xx} A	LDC-C100600-DHT _{xx} B
LDC-C100600-EHT _{xx} A	LDC-C100600-EHT _{xx} B
LDC-C150400-DHT _{xx} A	LDC-C150400-DHT _{xx} B
LDC-C150400-EHT _{xx} A	LDC-C150400-EHT _{xx} B
LDC-C150600-DHT _{xx} A	LDC-C150600-DHT _{xx} B
LDC-C150600-EHT _{xx} A	LDC-C150600-EHT _{xx} B
LDC-C030100-DHT _{xx} A	LDC-C030100-DHT _{xx} B
LDC-C030200-DHT _{xx} A	LDC-C030200-DHT _{xx} B

3. Using the screen image as a reference, configure the parameters as shown in the Setting column.

Parameter	Setting	Comment
Loop Configuration	Position Servo	–
Drive Resolution	200	5 µm encoder
	500	2 µm encoder
	1000	1 µm encoder
	2000	0.5 µm encoder
	10,000	0.1 µm encoder
	51200	20 µm pitch Sin/Cos encoder ⁽¹⁾
	25600	40 µm pitch Sin/Cos encoder
Drive Counts per	Motor Millimeter	–
Real Time Axis Information		
Attribute 1	Position Feedback	–

(1) Requires custom database file contact Application Engineering at 631.444.6600.

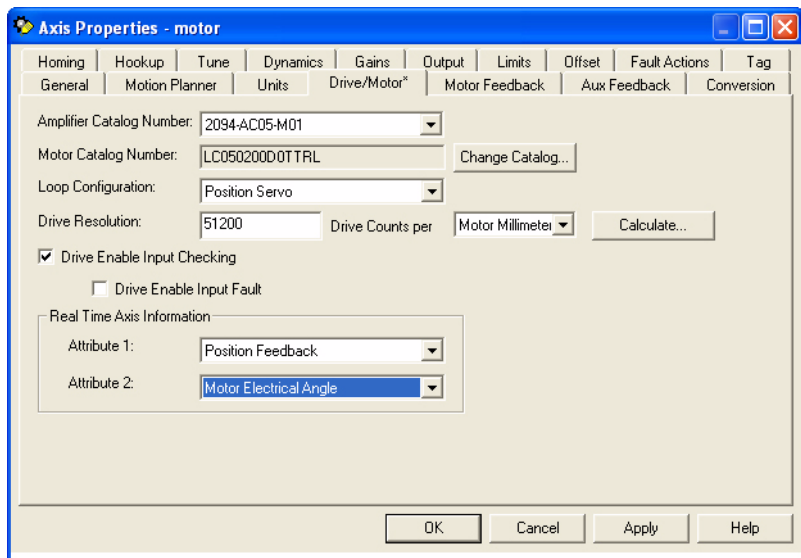

4. Click OK.

5. Click the Motor Feedback tab.

6. Using the screen image as a reference, configure the parameters as shown in the Setting column.

Parameter	Setting	Comment
Feedback Type	TTL or Sin/Cos	For RSLogix 5000 software,V16
	TTL with Hall or Sin/Cos with Hall	For RSLogix 5000 software, V17
Cycles	50	5 µm encoder
	125	2 µm encoder
	250	1 µm encoder
	500	0.5 µm encoder
	2500	0.1 µm encoder
	50	20 µm Sin/Cos encoder ⁽¹⁾
	25	40 µm Sin/Cos encoder
per	Millimeters	–
Interpolation Factor	4	TTL
	1024	Sin/Cos

(1) Requires custom database file contact Application Engineering at 631.444.6600.

RSLogix 5000 Software Version 15.00 and 16.00 TTL Encoder

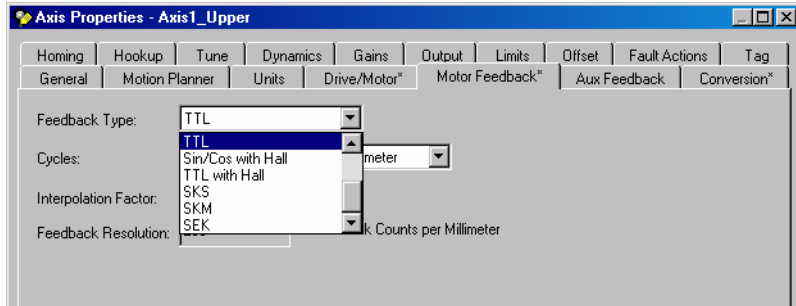

RSLogix 5000 Software Version 15.00 and 16.00 Sin/Cos Encoder

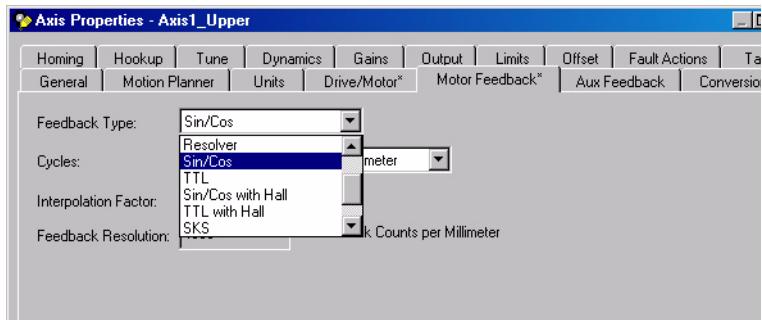

RSLogix 5000 Software Version 17.00 TTL Encoder

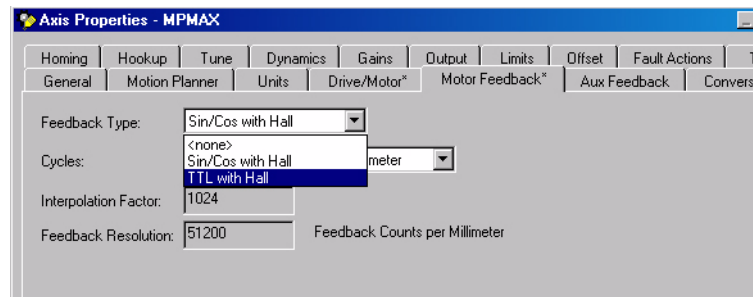

RSLogix 5000 Software Version 17.00 Sin/Cos Encoder

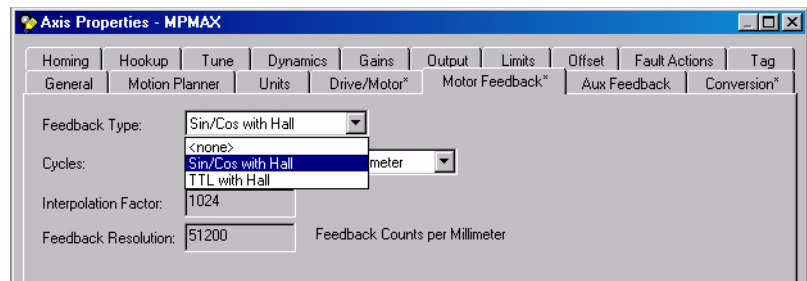

7. Click OK to set the values.
8. Click the Units tab.
9. Using the screen image as a reference, configure the parameters as shown in the Setting column.

Parameter	Setting
Position Units	mm
Average Velocity Timebase	0.25 s

You can change position units to inches, or other units, on this tab.

Example for a 5 μm resolution encoder:

200 drive cnts/mm x 25.4 mm/in.

Conversion Constant = 5080 drive cnts/in.

10. Click OK to set the values.

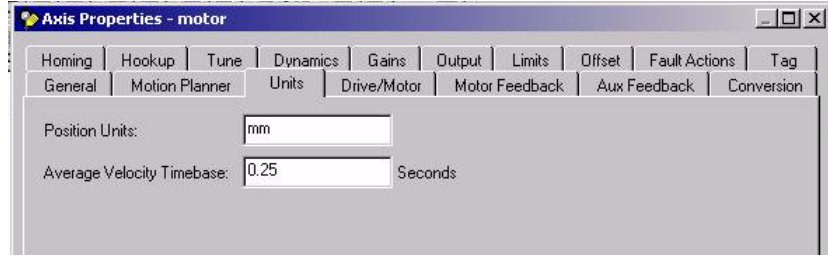

11. Click the Conversion tab.

12. Using the screen image as a reference, configure the parameters as shown in the Setting column.

Parameter	Setting	Comment
Positioning Mode	Linear	–
Conversion Constant	200	5 µm encoder
	500	2 µm encoder
	1000	1 µm encoder
	2000	0.5 µm encoder
	10,000	0.1 µm encoder
	51200	20 µm pitch Sin/Cos encoder ⁽¹⁾
	25600	40 µm pitch Sin/Cos encoder

(1) Requires custom database file contact Application Engineering at 631.444.6600.

13. Click OK.

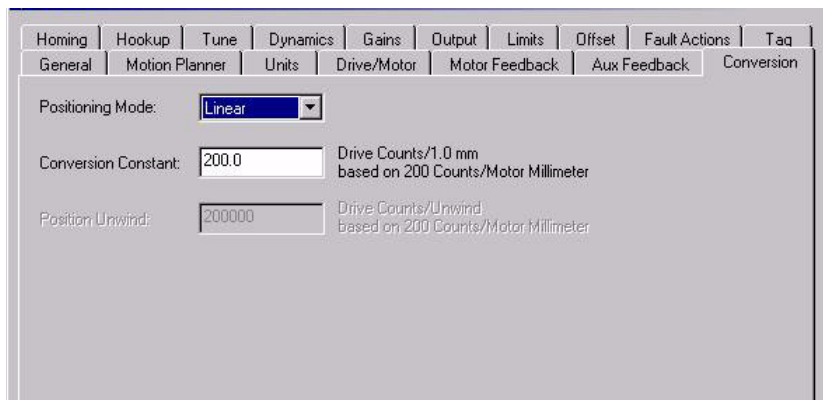

Set Up the Connection to an Ultra3000 Drive

This procedure configures the Ultra3000 drive for your linear motor and encoder combination.

For help using Ultraware software as it applies to setting up your linear motor, refer to [Additional Resources](#) on [page 7](#). This procedure assumes you are familiar with Ultraware software.

1. Open your Motor Configurator Utility.
2. Select the linear motor catalog number.
3. From the Edit menu, choose Duplicate.
4. Rename the Model.
5. Click Encoder Type and select either Incremental or Sin/Cos.
6. Click Lines Per Meter and enter the value.

The following tables list typical values for lines per meter.

Incremental	
Resolution	Value
10 µm	25,000
5 µm	50,000
2 µm	125,000
1 µm	250,000
0.5 µm	500,000
0.1 µm	2,500,000

Sin/Cos	
Encoder Scale Pitch	Value
100 µm	10,000
40 µm	25,000
20 µm	50,000

Incremental Encoder

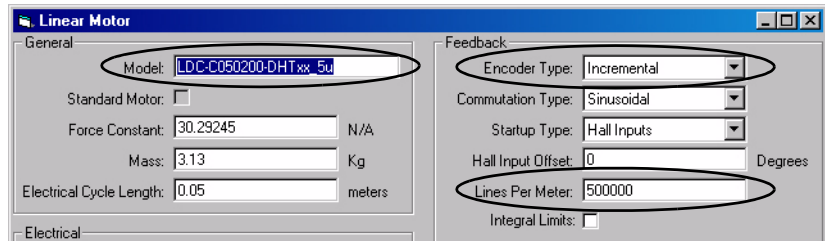

Sin/Cos Encoder

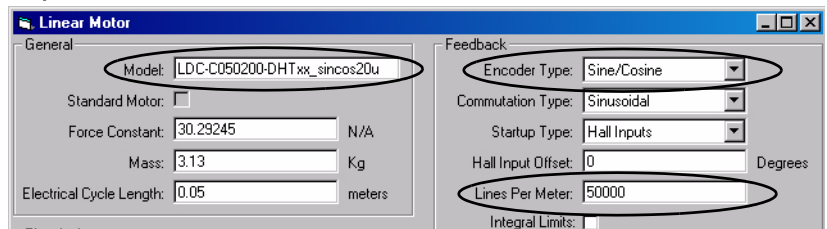

7. Click Close.
8. Open your Ultraware software.
9. Configure your Ultra3000 drive.
10. From the Workspace dialog select Motor.
11. Click Motor Model and choose the model you created from the pull-down menu.

If using an incremental encoder, you are finished. For Sin/Cos encoders continue with steps 12 and 13.

12. From the Workspace dialog, select Encoders.
13. Click Motor Encoder Interpolation and select a value from the pull-down menu.

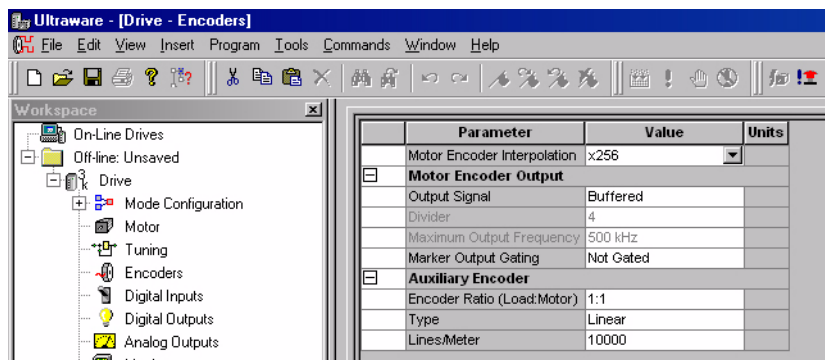

This table shows the encoder resolutions that could be achieved when using a 20 μ Sin/Cos encoder and different interpolation values.

Value	Encoder Resolution
X4	5 μ m
X8	2.5 μ m
X16	1.25 μ m
X32	0.625 μ m
X64	0.3125 μ m
X128	0.15625 μ m
X256	0.078125 μ m
X512	0.0390 μ m
X1024	0.01953125 μ m

Verify Motor Encoder Direction

In this section you use the monitor tags to evaluate the encoder installation.

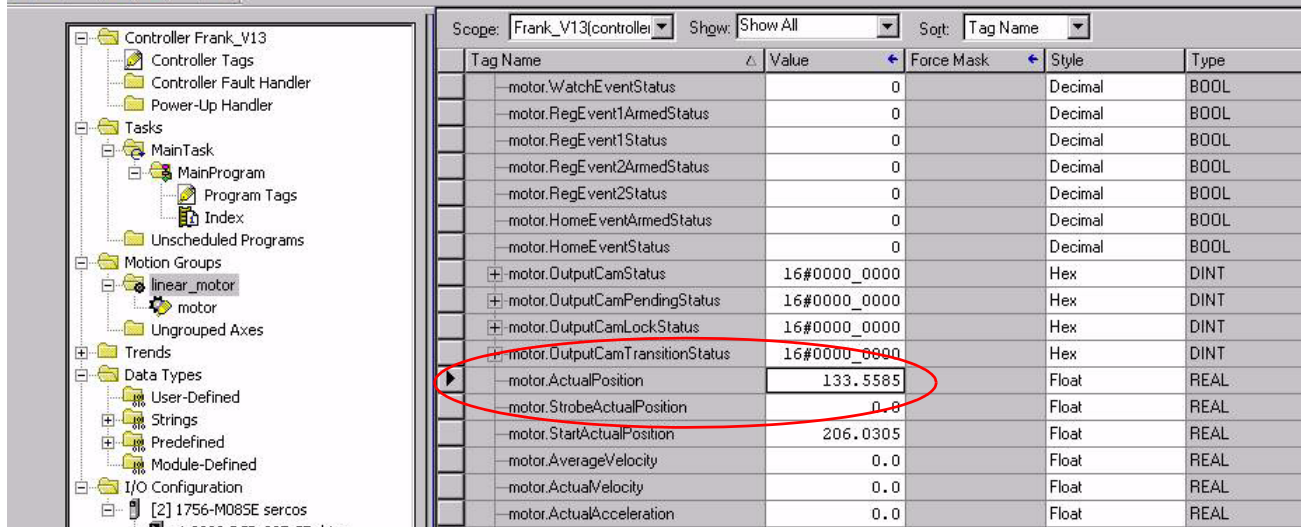

1. Disable the drive.
2. Note the ActualPosition tag value.
3. Move the axis in the positive direction.

See [page 43](#) for definition for positive direction.

4. Verify that the ActualPosition tag value increases as the axis moves.

If the positive direction of travel does not match what has been defined by the motor power and Hall Sensing wiring, then change the direction by re-wiring the encoder using the following table.

Move		To	
Encoder Phase	Drive CN2, pin	Encoder Phase	Drive CN2, pin
A+	1	B+	3
A-	2	B-	4
B+	3	A+	1
B-	4	A-	2

Verify Motor Encoder Resolution

This test compares the physically measured distance to the distance calculated by the software. It also verifies the encoder setting in the RSLogix 5000 software.

1. Measure and mark a fixed distance of travel on the axis.
2. Record the ActualPosition tag value with carriage at the starting position.
3. Move the carriage to the end position.
4. Record the ActualPosition tag value.
5. Calculate the distance moved using the record values.
6. Compare the actual distance and the calculated distance.

If the values do not match, verify resolution of installed encoder and the values used in the Motor Feedback, Conversion, and Units tabs.

Verify Linear Motor Wiring and Function

The Homing and Hookup tabs in RSLogix 5000 software check the motor power (U, V, W), Hall sensing signals (S1, S2, S3) and the encoder wiring are correct.

IMPORTANT

The following components must be wired correctly for your drive and linear motor to operate properly:

- Hall Effect module
 - Coil power wires
 - Thermistor
 - Encoder
-

Follow this steps to verify your motor wiring and function.

1. Click the Hookup tab.
2. Configure the parameters.

The following table shows the Suggested Settings.

Parameter	Suggested Setting
Test increment	60.00 mm
Drive Polarity	Positive

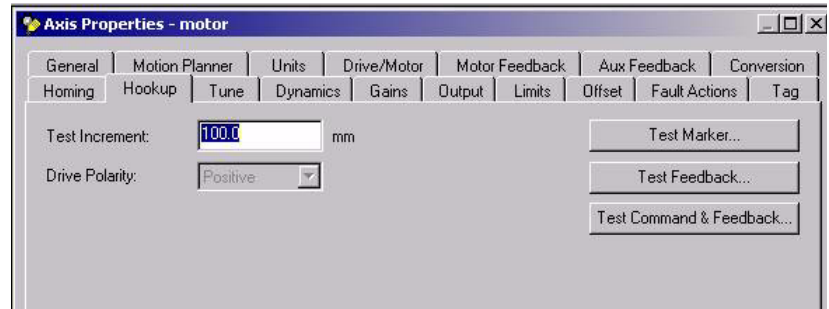
3. Click OK.**4.** Click Test Marker... to run the Test Marker test.

See your encoder user documentation for location and frequency of markers.

5. Position the coil so that it can move 60 mm (2.36 in.) in the forward or reverse direction.**6.** Click Test Feedback... to run the Test Feedback test.

Move the axis by hand at least 60 mm (2.36 in.) when prompted.

When using Allen-Bradley servo drives match the counting direction of your position feedback encoder to the direction the motor moves when positive current is applied.

7. Click Test Command & Feedback... to run the Test Command & Feedback test.

Follow the on-screen instructions.

IMPORTANT

Be sure all the tests on the Hookup tab have passed before proceeding.

IMPORTANT

When using Kinetix 6000 and Kinetix 2000 drives, the Test Command Feedback test may pass even though the Hall Effect module is not wired correctly.

8. Click the Tune tab.



WARNING Large Position Error Tolerances, such as those calculated by the Auto Tune function in RSLogix 5000 programming software, or when configuring a new axis with RSLogix 5000 software, can lead to undetected and repetitive high energy impacts against axis end stops if proper precautions are not in place. These tolerances can also lead to undetected and repetitive high energy impacts against unexpected obstructions. Such impacts can lead to equipment damage and/or serious injury.

To identify the safety concerns that you have with default Position Error Tolerance or after an Auto-Tune Function, go to the [Rockwell Automation Knowledgebase](#). Click Find Technical Support Answers and search for Answer Id 55937.

9. Configure the parameters in the Tune tab as suggested in the Initial Setting column. Leave all other tune options off for your first pass. If necessary, reduce the Velocity Loop Proportional Gain to maintain stability.

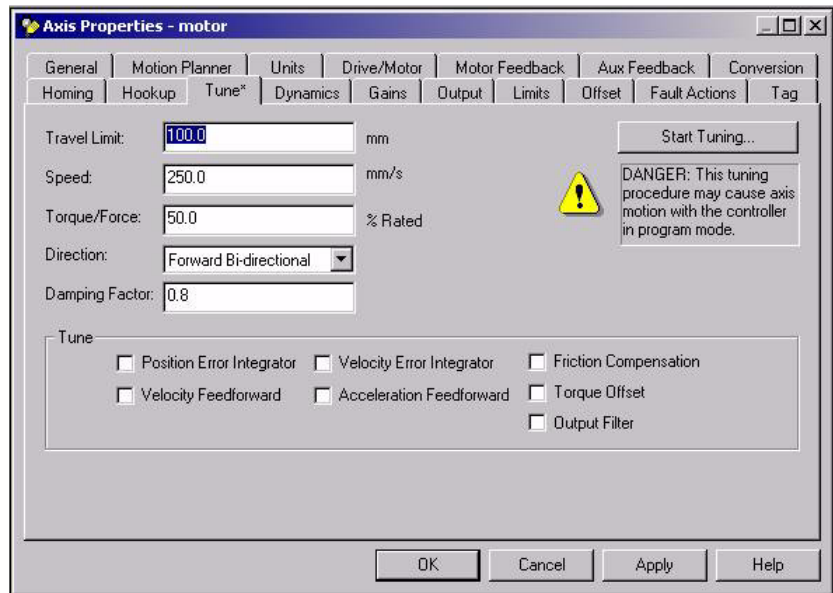

Parameter	Initial Setting	Units	Note
Travel Limit	100	mm	Suggested
Speed	250	mm/sec	–
Torque/Force	50	% Rated	–
Direction	Forward Bi-directional	–	–
Damping Factor	0.8	–	(default)

10. Click the Homing tab.
11. Choose Sequence to Switch-Marker, or Torque Level-Marker when a repeatable power-up position is desired.

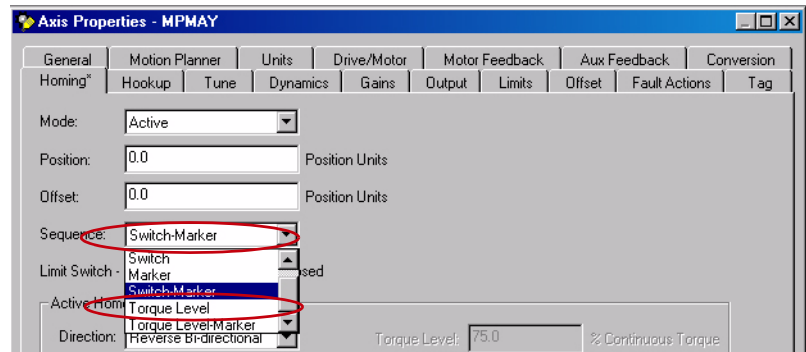

Typical linear TTL and Sin/Cos encoders will home repeatability to within one count of resolution when their index mark is used.

Additional Adjustments for Cooling Plate Option

If your linear servo motor has the cooling plate option installed, catalog number LDC-xxxxxx-CP, follow these steps to adjust Continuous Torque/Force Limit.

1. Click Limits tab.
2. Set the Continuous Torque/Force Limit to reflect the motor cooling configuration. For linear motors this field data entry is limited to integer values between 0...150 percent.

Cooling Option Used	Value
No cooling plate	0...100%
Cooling plate with forced air	0...120%
Cooling plate with forced water	0...150%

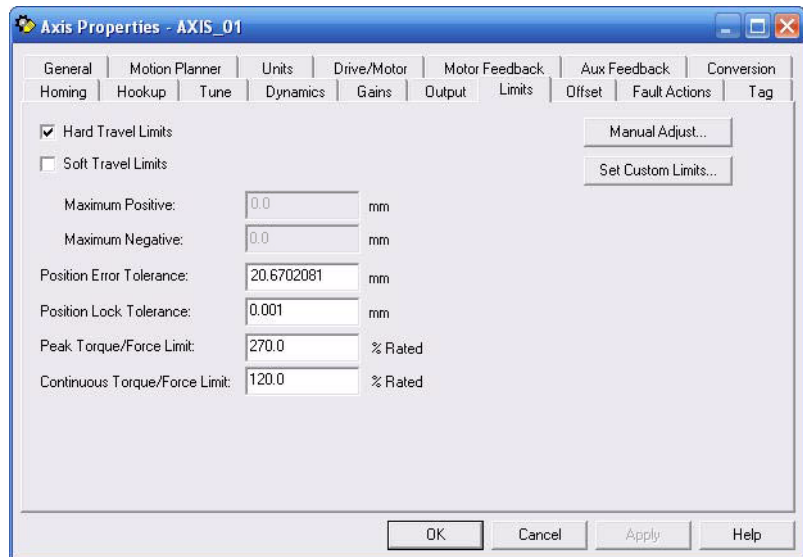

IMPORTANT

Increasing or decreasing the motor continuous current rating does not change the drives's continuous current limiting.

Specifications and Dimensions

Introduction

This appendix provides product specifications and mounting dimensions for your LDC-Series iron core linear servo motor components

Topic	Page
Performance Specifications	60
General Specifications	66
Product Dimensions	69

Performance Specifications

These tables provide performance specifications for the LDC-Series iron core linear servo motors.

Common Performance Specifications

These performance specifications apply to all LDC-Series iron core linear servo motors.

Attribute	Value
Motor type	3 phase, wye winding, synchronous permanent magnet stator, non-ventilated linear motor
Operating speed, max	10 m/s (32.8 ft/s)
Operating voltage, (not for direct connection to AC line)	460V AC rms
Dielectric rating of motor power connections (U,V,W), to ground for 1.0 s ⁽¹⁾	2500V AC rms 50/60 Hz
Cogging torque	< 5% of the continuous force
Applied bus voltage, max ⁽²⁾	650V DC
Electrical cycle length	50 mm (1.9685 in.)
Coil temperature, max	130 °C (266 °F)
Insulation class	130 °C (266 °F) Class B
Thermal time constant, Ref, winding to ambient	45 min
Paint color	Black

(1) Tested during manufacturing process. Do not re-apply test voltage. Contact Application Engineering (631.344.6600) for advice on testing coils post production.

(2) Maximum cable length is 10 m (32.8 ft). Consult Application Engineering (631.344.6600) for applications requiring longer cables.

Performance Specifications

Motor performance specifications are with sinusoidal commutation. Cooling options include NC (no cooling), AC (air cooling), and WC (water cooling).

LDC-Series Iron Core Linear Motors (30 mm frame size)

Attribute	Units	Symbol	LDC-C030100-DxTxx			LDC-C030200-DxTxx			LDC-C030200-ExTxx		
			NC	AC	WC	NC	AC	WC	NC	AC	WC
Force, continuous ^{(1) (2) (3)}	N (lbf)	F_c	74 (17)	93 (21)	111 (25)	148 (33)	185 (42)	222 (50)	148 (33)	185 (42)	222 (50)
Force, peak ⁽⁴⁾	N (lbf)	F_p	188 (42)			375 (84)					
Thermal resistance	°C/W	R_{th}	2.24	1.43	1.00	1.12	0.72	0.50	1.12	0.72	0.50
Force constant ^{(5) (6) (7)}	N/A _{pk} (lbf/A _{pk})	K_f	18.2 (4.1)			18.2 (4.1)			36.4 (8.2)		
Back EMF constant p-p ^{(5) (6) (7)}	V _p /m/s (V _p /in/s)	K_e	21.5 (0.55)			21.5 (0.55)			43.0 (1.09)		
Current, peak ^{(4) (6)}	A _{pk} (A _{rms})	I_p	12.1 (8.6)			24.3 (17.1)			12.1 (8.6)		
Current, continuous ^{(1) (2) (3) (6)}	A _{pk} (A _{rms})	I_c	4.1 (2.88)	5.1 (3.6)	6.1 (4.3)	8.1 (5.8)	10.2 (7.2)	12.2 (8.6)	4.1 (2.9)	5.1 (3.6)	6.1 (4.3)
Resistance p-p @ 20 °C (68 °F) ^{(5) (7)}	Ohms	R_{20}	2.256			1.128			4.51		
Inductance p-p ^{(5) (7)}	mH	L	21.6			10.8			43.0		
Magnetic attraction ⁽⁸⁾	N (lbf)	F_a	393 (88)			786 (177)					

(1) Coils at maximum temperature, 130 °C (266 °F), mounted to an aluminium heat sink whose area is noted in table on [page 67](#), and at 40 °C (104 °F) ambient.

(2) Continuous force and current based on coil moving with all phases sharing the same load in sinusoidal commutation.

(3) For standstill conditions, multiply continuous force and continuous current by 0.9.

(4) Calculated at 20% duty cycle for 1.0 second max. Some applications may produce significantly higher peak forces. Call Applications Engineering (631.344.6600) for details.

(5) Winding parameters listed are measured line-to-line (phase-to-phase).

(6) Currents and voltages listed are measured 0-peak of the sine wave unless noted as rms.

(7) Specifications are ±10%. Phase-to-phase inductance is ±30%.

(8) All specifications are at the standard reference air gap as shown in the drawing on [page 71](#) and [page 73](#).

LDC-Series Iron Core Linear Motors (50 mm frame size)

Attribute	Units	Symbol	LDC-C050100-DxTx			LDC-C050200-DxTx			LDC-C050300-DxTx			LDC-C050300-ExTx			
			NC	AC	WC	NC	AC	WC	NC	AC	WC	NC	AC	WC	
Force, continuous ⁽¹⁾ (2) (3)	N (lbf)	F _c	119 (27)	149 (34)	179 (40)	240 (54)	299 (67)	359 (81)	240 (54)	299 (67)	359 (81)	363 (82)	453 (102)	544 (122)	
Force, peak ⁽⁴⁾	N (lbf)	F _p	302 (68)	600 (135)			941 (212)			941 (212)			941 (212)		
Thermal resistance	°C/W	R _{th}	1.44	0.92	0.64	0.71	0.46	0.32	0.71	0.46	0.32	0.48	0.31	0.21	
Force constant ⁽⁵⁾ (6) (7)	N/A _{pk} (lbf/A _{pk})	K _f	30.3 (6.8)	30.3 (6.8)			60.7 (13.6)			60.7 (13.6)			92.4 (20.8)		
Back EMF constant p-p ⁽⁵⁾ (6) (7)	V _p /m/s (V _p /in/s)	K _e	35.8 (0.91)	35.8 (0.91)			71.7 (1.82)			71.7 (1.82)			109.1 (2.77)		
Current, peak ⁽⁴⁾ (6)	A _{pk} (A _{rms})	I _p	11.7 (8.3)	23.3 (16.5)			11.6 (8.2)			11.6 (8.2)			12.0 (8.5)		
Current, continuous ⁽¹⁾ (2) (3) (6)	A _{pk} (A _{rms})	I _c	3.9 (2.8)	4.9 (3.5)	5.9 (4.2)	7.9 (5.6)	9.9 (7.0)	11.8 (8.4)	3.9 (2.8)	4.9 (3.5)	5.9 (4.2)	11.8 (8.3)	14.7 (10.4)	17.7 (12.5)	
Resistance p-p @ 20 °C (68 °F) ⁽⁵⁾ (7)	Ohms	R ₂₀	3.76			1.88			7.52			11.28			
Inductance p-p ⁽⁵⁾ (7)	mH	L	36			18			72			108			
Magnetic attraction ⁽⁸⁾	N (lbf)	F _a	690 (155)			1379 (310)			2069 (465)			2069 (465)			

(1) Coils at maximum temperature, 130 °C (266 °F), mounted to an aluminium heat sink whose area is noted in table on [page 67](#), and at 40 °C (104 °F) ambient.

(2) Continuous force and current based on coil moving with all phases sharing the same load in sinusoidal commutation.

(3) For standstill conditions, multiply continuous force and continuous current by 0.9.

(4) Calculated at 20% duty cycle for 1.0 second max. Some applications may produce significantly higher peak forces. Call Applications Engineering (631.344.6600) for details.

(5) Winding parameters listed are measured line-to-line (phase-to-phase).

(6) Currents and voltages listed are measured 0-peak of the sine wave unless noted as rms.

(7) Specifications are ±10%. Phase-to-phase inductance is ±30%.

(8) All specifications are at the standard reference air gap as shown in the drawing on [page 71](#) and [page 73](#).

LDC-Series Iron Core Linear Motors (75 mm frame size)

Attribute	Units	Symbol	LDC-C075200-D-xTxx			LDC-C075200-ExTxx			LDC-C075300-D-xTxx			LDC-C075300-ExTxx			LDC-C075400-D-xTxx			LDC-C075400-ExTxx		
			NC	AC	WC	NC	AC	WC	NC	AC	WC	NC	AC	WC	NC	AC	WC	NC	AC	WC
Force, continuous ⁽¹⁾ (2)(3)	N (lbf)	F _c	348 (78)	435 (98)	523 (117)	348 (78)	435 (98)	523 (117)	523 (117)	653 (147)	784 (176)	523 (117)	653 (147)	784 (176)	697 (157)	871 (196)	1045 (235)	697 (157)	871 (196)	1045 (235)
Force, peak ⁽⁴⁾	N (lbf)	F _p	882 (198)						1368 (308)			1824 (410)								
Thermal resistance	°C/W	R _{th}	0.58	0.37	0.26	0.58	0.37	0.26	0.39	0.25	0.17	0.39	0.25	0.17	0.29	0.19	0.13	0.29	0.19	0.13
Force constant ⁽⁵⁾ (6)(7)	N/A _{pk} (lbf/A _{pk})	K _f	45.5 (10.2)			91.0 (20.5)			45.5 (10.2)			136.5 (30.7)			45.5 (10.2)			91.0 (20.5)		
Back EMF constant p-p ⁽⁵⁾ (6)(7)	V _p /m/s (V _p /in/s)	K _e	53.7 (1.37)			107.5 (2.73)			53.7 (1.37)			161.2 (4.10)			53.7 (1.37)			107.5 (2.73)		
Current, peak ⁽⁴⁾ (6)	A _{pk} (A _{rms})	I _p	22.9 (16.2)			11.5 (8.1)			35.6 (25.1)			11.9 (8.4)			47.4 (33.5)			23.7 (16.8)		
Current, continuous ⁽¹⁾ (2)(3)(6)	A _{pk} (A _{rms})	I _c	7.7 (5.4)	9.6 (6.8)	11.5 (8.1)	3.8 (2.7)	4.8 (3.4)	5.7 (4.1)	11.5 (8.1)	14.4 (10.2)	17.2 (12.2)	3.8 (2.7)	4.8 (3.4)	5.7 (4.1)	15.3 (10.8)	19.1 (13.5)	23.0 (16.2)	7.7 (5.4)	9.6 (6.8)	11.5 (8.1)
Resistance p-p @ 20 °C (68 °F) ⁽⁵⁾ (7)	Ohms	R ₂₀	2.47			9.88			1.65			14.82			1.24			4.94		
Inductance p-p ⁽⁵⁾ (7)	mH	L	24			95			16			142			12			47		
Magnetic attraction ⁽⁸⁾	N (lbf)	F _a	2000 (450)						2999 (674)						3999 (899)					

- (1) Coils at maximum temperature, 130 °C (266 °F), mounted to an aluminum heat sink whose area is noted in table on [page 6Z](#), and at 40 °C (104 °F) ambient.
- (2) Continuous force and current based on coil moving with all phases sharing the same load in sinusoidal commutation.
- (3) For standstill conditions, multiply continuous force and continuous current by 0.9.
- (4) Calculated at 20% duty cycle for 1.0 second max. Some applications may produce significantly higher peak forces. Call Applications Engineering (631.344.6600) for details.
- (5) Winding parameters listed are measured line-to-line (phase-to-phase).
- (6) Currents and voltages listed are measured 0-peak of the sine wave unless noted as rms.
- (7) Specifications are ±10%. Phase-to-phase inductance is ±30%.
- (8) All specifications are at the standard reference air gap as shown in the drawing on [page 71](#) and [page 73](#).

LDC-Series Iron Core Linear Motors (100 mm frame size)

Attribute	Units	Symbol	LDC-C100300-DxTxx			LDC-C100300-ExTxx			LDC-C100400-DxTxx			LDC-C100400-ExTxx			LDC-C100600-DxTxx			LDC-C100600-ExTxx						
			NC	AC	WC	NC	AC	WC	NC	AC	WC	NC	AC	WC	NC	AC	WC	NC	AC	WC				
Force, continuous ⁽¹⁾⁽²⁾⁽³⁾	N (lbf)	F _c	674 (152)	843 (190)	1012 (227)	674 (152)	843 (190)	1012 (227)	899 (202)	1124 (253)	1349 (303)	899 (202)	1124 (253)	1349 (303)	1686 (379)	2023 (455)	1349 (303)	1686 (379)	2023 (455)					
Force, peak ⁽⁴⁾	N (lbf)	F _p	1767 (397)	2356 (530)			2356 (530)			3534 (794)			3534 (794)			3534 (794)			3534 (794)					
Thermal resistance	°C/W	R _{th}	0.33	0.21	0.15	0.33	0.21	0.15	0.25	0.16	0.11	0.25	0.16	0.11	0.11	0.07	0.17	0.11	0.07	0.17	0.11	0.07		
Force constant ⁽⁵⁾⁽⁶⁾⁽⁷⁾	N/A _{pk} (lbf/A _{pk})	K _f	60.7 (13.6)	182.0 (40.9)			182.0 (40.9)			60.7 (13.6)			60.7 (13.6)			60.7 (13.6)			60.7 (13.6)			60.7 (13.6)		
Back EMF constant p-p ⁽⁵⁾⁽⁶⁾⁽⁷⁾	V _p /m/s (V _p /m/s)	K _e	71.7 (1.82)	215.0 (5.46)			215.0 (5.46)			71.7 (1.82)			71.7 (1.82)			71.7 (1.82)			71.7 (1.82)			71.7 (1.82)		
Current, peak ⁽⁴⁾⁽⁶⁾	A _{pk} (A _{rms})	I _p	34.3 (24.2)	11.4 (8.1)			11.4 (8.1)			45.7 (32.3)			45.7 (32.3)			45.7 (32.3)			68.5 (48.4)			68.5 (48.4)		
Current, continuous ⁽¹⁾⁽²⁾⁽³⁾⁽⁶⁾	A _{pk} (A _{rms})	I _c	11.1 (7.9)	13.9 (9.8)	16.7 (11.8)	3.7 (2.6)	4.6 (3.3)	5.6 (3.9)	14.8 (10.5)	18.5 (13.1)	22.2 (15.7)	7.4 (5.2)	9.3 (6.5)	11.1 (7.9)	22.2 (15.7)	27.8 (19.7)	11.1 (7.9)	13.9 (9.8)	16.7 (11.8)	22.2 (15.7)	27.8 (19.7)	33.3 (23.6)		
Resistance p-p @ 20 °C ⁽⁵⁾⁽⁷⁾	Ohms	R ₂₀	2.04	18.36			18.36			1.53			1.53			1.02			1.02			1.02		
Inductance p-p ⁽⁵⁾⁽⁷⁾	mH	L	20	184			184			15			15			10			10			10		
Magnetic attraction ⁽⁸⁾	N (lbf)	F _a	3930 (883)	5240 (1178)			5240 (1178)			7860 (1767)			7860 (1767)			7860 (1767)			7860 (1767)			7860 (1767)		

(1) Coils at maximum temperature, 130 °C (266 °F), mounted to an aluminium heat sink whose area is noted in table on [page 67](#), and at 40 °C (104 °F) ambient.

(2) Continuous force and current based on coil moving with all phases sharing the same load in sinusoidal commutation.

(3) For standstill conditions, multiply continuous force and continuous current by 0.9.

(4) Calculated at 20% duty cycle for 1.0 second max. Some applications may produce significantly higher peak forces. Call Applications Engineering (631.344.6600) for details.

(5) Winding parameters listed are measured line-to-line (phase-to-phase).

(6) Currents and voltages listed are measured 0-peak of the sine wave unless noted as rms.

(7) Specifications are ±10%. Phase-to-phase inductance is ±30%.

(8) All specifications are at the standard reference air gap as shown in the drawing on [page 71](#) and [page 73](#).

LDC-Series Iron Core Linear Motors (150 mm frame size)

Attribute	Units	Symbol	LDC-C150400-DxTx			LDC-C150400-ExTx			LDC-C150600-DxTx			LDC-C150600-ExTx		
			NC	AC	WC	NC	AC	WC	NC	AC	WC	NC	AC	WC
Force, continuous ⁽¹⁾ (2) (3)	N (lbf)	F _c	1281 (288)	1601 (360)	1922 (432)	1281 (288)	1601 (360)	1922 (432)	1922 (432)	2402 (540)	2882 (648)	1922 (432)	2402 (540)	2882 (648)
Force, peak ⁽⁴⁾	N (lbf)	F _p	3498 (786)			5246 (1179)			5246 (1179)			5246 (1179)		
Thermal resistance	°C/W	R _{th}	0.20	0.13	0.09	0.20	0.13	0.09	0.13	0.09	0.06	0.13	0.09	0.06
Force constant ⁽⁵⁾ (6) (7)	N/A _{pk} (lbf/A _{pk})	K _f	91.0 (20.5)			182.0 (40.9)			91.0 (20.5)			182.0 (40.9)		
Back EMF constant p-p ⁽⁵⁾ (6) (7)	V _p /m/s (V _p /in/s)	K _e	107.5 (2.73)			215.0 (5.46)			107.5 (2.73)			215.0 (5.46)		
Current, peak ⁽⁴⁾ (6)	A _{pk} (A _{rms})	I _p	45.2 (32.0)			22.6 (16.0)			67.8 (47.9)			33.9 (24.0)		
Current, continuous ⁽¹⁾ (2) (3) (6)	A _{pk} (A _{rms})	I _c	14.1 (10.0)	17.6 (12.4)	21.1 (14.9)	7.0 (5.0)	8.8 (6.2)	10.6 (7.5)	21.1 (14.9)	26.4 (18.7)	31.7 (22.4)	10.6 (7.5)	13.2 (9.3)	15.8 (11.2)
Resistance p-p @ 20 °C (68 °F) ⁽⁵⁾ (7)	Ohms	R ₂₀	2.12			8.48			1.41			5.65		
Inductance p-p ⁽⁵⁾ (7)	mH	L	22			86			14			58		
Magnetic attraction ⁽⁸⁾	N (lbf)	F _a	7860 (1768)			11790 (2652)			11790 (2652)			11790 (2652)		

- (1) Coils at maximum temperature, 130 °C (266 °F), mounted to an aluminium heat sink whose area is noted in table on [page 67](#), and at 40 °C (104 °F) ambient.
- (2) Continuous force and current based on coil moving with all phases sharing the same load in sinusoidal commutation.
- (3) For standstill conditions, multiply continuous force and continuous current by 0.9.
- (4) Calculated at 20% duty cycle for 1.0 second max. Some applications may produce significantly higher peak forces. Call Applications Engineering (631.344.6600) for details.
- (5) Winding parameters listed are measured line-to-line (phase-to-phase).
- (6) Currents and voltages listed are measured 0-peak of the sine wave unless noted as rms.
- (7) Specifications are ±10%. Phase-to-phase inductance is ±30%.
- (8) All specifications are at the standard reference air gap as shown in the drawing on [page 71](#) and [page 73](#).

General Specifications

These tables provide weight, heat sink, environmental, and cooling plate specifications for LDC-Series iron core linear motors.

Weight Specification

Weight Specifications - Motor Coil with Flying Leads and Cooling Plate

Cat. No. Coil	Weight, approx. kg (lb)	Cat. No. Cooling Plate	Weight, approx. kg (lb)	Coil and Cooling Plate (combined) Weight, approx. kg (lb)
LDC-C030100-DHT20	1.41 (3.1)	LDC-030-100-CP	0.12 (0.26)	1.53 (3.4)
LDC-C030200-xHT20	2.27 (5.0)	LDC-030-200-CP	0.20 (0.44)	2.47 (5.4)
LDC-C050100-DHT20	2.05 (4.5)	LDC-050-100-CP	0.15 (0.32)	2.19 (4.8)
LDC-C050200-xHT20	3.18 (7.0)	LDC-050-200-CP	0.25 (0.55)	3.43 (7.6)
LDC-C050300-xHT20	4.55 (10.0)	LDC-050-300-CP	0.36 (0.79)	4.91 (10.8)
LDC-C075200-xHT20	4.55 (10.0)	LDC-075-200-CP	0.39 (0.85)	4.93 (10.9)
LDC-C075300-xHT20	6.36 (14.0)	LDC-075-300-CP	0.56 (1.23)	6.92 (15.2)
LDC-C075400-xHT20	8.18 (18.0)	LDC-075-400-CP	0.73 (1.60)	8.91 (19.6)
LDC-C100300-xHT20	7.73 (17.0)	LDC-100-300-CP	0.73 (1.60)	8.46 (18.6)
LDC-C100400-xHT20	10.0 (22.0)	LDC-100-400-CP	0.96 (2.10)	10.96 (24.1)
LDC-C100600-xHT20	15.45 (34.0)	LDC-100-600-CP	1.39 (3.05)	16.84 (37.0)
LDC-C150400-xHT20	14.55 (32.0)	LDC-150-400-CP	1.93 (4.24)	16.47 (36.2)
LDC-C150600-xHT20	21.36 (47.0)	LDC-150-600-CP	2.86 (6.29)	24.22 (53.3)

Weight Specifications - Motor Coil with Connectors and Cooling Plate

Cat. No. Coil	Weight, approx. kg (lb)	Cat. No. Cooling Plate	Weight, approx. kg (lb)	Coil and Cooling Plate (combined) Weight, approx. kg (lb)
LDC-C030100-DHT11	1.61 (3.55)	LDC-030-100-CP	0.12 (0.26)	1.73 (3.81)
LDC-C030200-xHT11	2.47 (5.44)	LDC-030-200-CP	0.20 (0.44)	2.67 (5.89)
LDC-C050100-DHT11	2.25 (4.96)	LDC-050-100-CP	0.15 (0.32)	2.40 (5.29)
LDC-C050200-xHT11	3.38 (7.45)	LDC-050-200-CP	0.25 (0.55)	3.63 (8.00)
LDC-C050300-xHT11	4.75 (10.47)	LDC-050-300-CP	0.36 (0.79)	5.11 (11.3)
LDC-C075200-xHT11	4.75 (10.47)	LDC-075-200-CP	0.39 (0.85)	5.14 (11.33)
LDC-C075300-xHT11	6.56 (14.46)	LDC-075-300-CP	0.56 (1.23)	7.12 (15.70)
LDC-C075400-xHT11	8.38 (18.47)	LDC-075-400-CP	0.73 (1.60)	9.11 (20.08)
LDC-C100300-xHT11	7.91 (17.4)	LDC-100-300-CP	0.73 (1.60)	8.64 (18.6)
LDC-C100400-xHT11	10.2 (22.5)	LDC-100-400-CP	0.96 (2.10)	11.16 (24.60)
LDC-C100600-xHT11	15.65 (34.5)	LDC-100-600-CP	1.39 (3.05)	17.04 (37.57)
LDC-C150400-xHT11	14.75 (32.5)	LDC-150-400-CP	1.93 (4.24)	16.68 (36.74)
LDC-C150600-xHT11	21.56 (47.5)	LDC-150-600-CP	2.86 (6.29)	24.42 (53.79)

Weight Specifications - Motor Magnet Track

Cat. No. Magnet Track	Weight, approx. kg (lb)
LDC-M030100	0.47 (1.02)
LDC-M050100	0.66 (1.46)
LDC-M075100	0.90 (1.98)
LDC-M100100	1.14 (2.51)
LDC-M150100	1.62 (3.57)
LDC-M030500	2.35 (5.12)
LDC-M050500	3.32 (7.28)
LDC-M075500	4.5 (9.92)
LDC-M100500	5.7 (12.57)
LDC-M150500	8.08 (17.81)

Carriage Weight and Heat Sink Area Requirements

Cat. No.	Required Heat Sink Area cm² (in.²)	Required Carriage Plate Weight, approx. kg (lb)
LDC-C030100-DHT _{xx}	150 X 200 (6 X 8)	1.1 (2.6)
LDC-C030200-xHT _{xx}	150 X 300 (6 X 12)	1.6 (3.6)
LDC-C050100-DHT _{xx}	200 X 200 (8 X 8)	1.8 (4)
LDC-C050200-xHT _{xx}	200 X 300 (8 X 12)	2.7 (6)
LDC-C050300-xHT _{xx}	200 X 400 (8 X 16)	3.6 (8)
LDC-C075200-xHT _{xx}	250 X 300 (10 X 12)	5.4 (12)
LDC-C075300-xHT _{xx}	250 X 400 (10 X 16)	7.3 (16)
LDC-C075400-xHT _{xx}	250 X 500 (10 X 20)	9.1 (20)
LDC-C100300-xHT _{xx}	300 X 400 (12 X 16)	8.7 (19.2)
LDC-C100400-xHT _{xx}	300 X 500 (12 X 20)	10.9 (24)
LDC-C100600-xHT _{xx}	300 X 750 (12 X 30)	19.6 (43.2)
LDC-C150400-xHT _{xx}	400 X 500 (16 X 20)	21.8 (48)
LDC-C150600-xHT _{xx}	400 X 750 (16 X 30)	32.7 (72)

Cooling Plate Flow Rate Specifications

Cat. No. Coil	Cat. No. Cooling Plate	Air Flow Rate ⁽¹⁾ L/min (ft ³ /hr)	Water Flow Rate ⁽³⁾ bar (psi)
LDC-C030100-xxxxx	LDC-030-100-CP	N/A ⁽²⁾	N/A ⁽²⁾
LDC-C030200-xxxxx	LDC-030-200-CP	N/A ⁽²⁾	N/A ⁽²⁾
LDC-C050100-xxxxx	LDC-050-100-CP	N/A ⁽²⁾	0.41 (6)
LDC-C050200-xxxxx	LDC-050-200-CP	N/A ⁽²⁾	0.48 (7)
LDC-C050300-xxxxx	LDC-050-300-CP	N/A ⁽²⁾	0.55 (8)
LDC-C075200-xxxxx	LDC-075-200-CP	N/A ⁽²⁾	0.48 (7)
LDC-C075300-xxxxx	LDC-075-300-CP	N/A ⁽²⁾	0.55 (8)
LDC-C075400-xxxxx	LDC-075-400-CP	N/A ⁽²⁾	0.69 (10)
LDC-C100300-xxxxx	LDC-100-300-CP	61.4 (130)	0.69 (10)
LDC-C100400-xxxxx	LDC-100-400-CP	N/A ⁽²⁾	0.83 (12)
LDC-C100600-xxxxx	LDC-100-600-CP	47.2 (100)	0.97 (14)
LDC-C150400-xxxxx	LDC-150-400-CP	N/A ⁽²⁾	0.83 (12) ⁽⁴⁾
LDC-C150600-xxxxx	LDC-150-600-CP	N/A ⁽²⁾	0.93 (13.5) ⁽⁴⁾

- (1) These are the flow rates required to maintain air pressure at 0.689 bar (10 lb/in.²).
 (2) This flow rate is not available. Call Application Engineering (631-344-6600) for assistance.
 (3) These are the flow rates required to maintain water pressure at 3.8 L/min (1 gal/min).
 (4) These are the flow rates required to maintain water pressure at 7.57 L/min (2 gal/min).

Environmental Specifications

Attribute	Value
Temperature, operating ambient	0...40 °C (32...104 °F)
Temperature, storage ambient	-30...70 °C (-22...158 °F)
Humidity, relative non-condensing	5...95%
Liquid/dust protection	IP 65
Shock, max	20 g peak, 6 ms duration
Vibration, max	2.5 g peak, 30 to 2000 Hz for 1 hr

Certifications

Certification ⁽¹⁾ (when product is marked)	Standards
c-UL-us	UL recognized to U.S. and Canadian safety standards (UL 1004-1 and 840 File E230241).
CE	European Union 2004/108/EC EMC Directive compliant with EN 61800-3:2004: Adjustable Speed Electrical Power Drive Systems - Part 3; EMC Product Standard including specific test methods. European Union 2006/95/EC Low Voltage Directive compliant with: <ul style="list-style-type: none"> EN 60034-1:2004 Rotating Electrical Machines, Part I: Rating and Performance. EN 60204-1:2006 Safety of Machinery – Electrical Equipment of Machines, Part 1: General Requirements.

Product Dimensions

LDC-Series iron core linear servo motor components are designed to metric dimensions. Inch dimensions are conversions from millimeters. Untoleranced dimensions are for reference.

Motor Coil Dimensions

LDC-Series Iron Core Linear Motor Coil Dimensions (LDC-C030/050/075/100xxx-xHT20) with Flying Leads

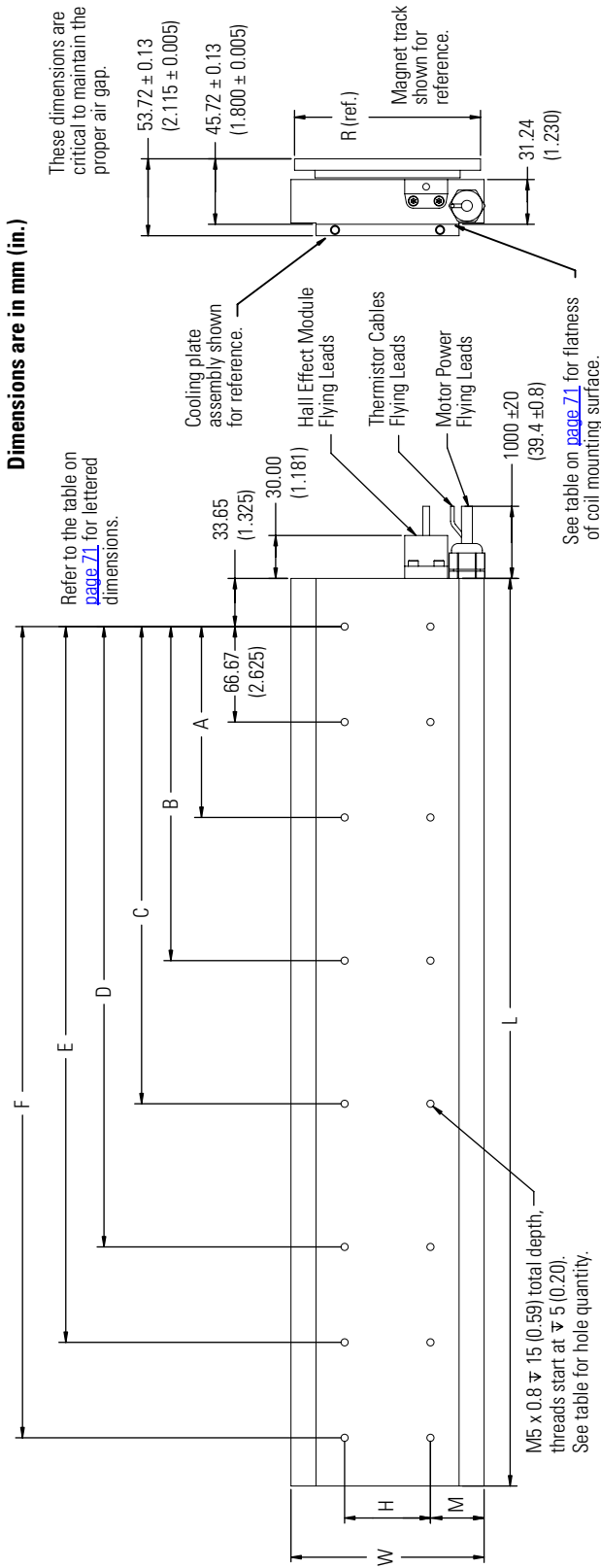

LDC-Series Iron Core Linear Motor Coil Dimensions (LDC-C030/050/075/100xxx-xHT11) with Connectors

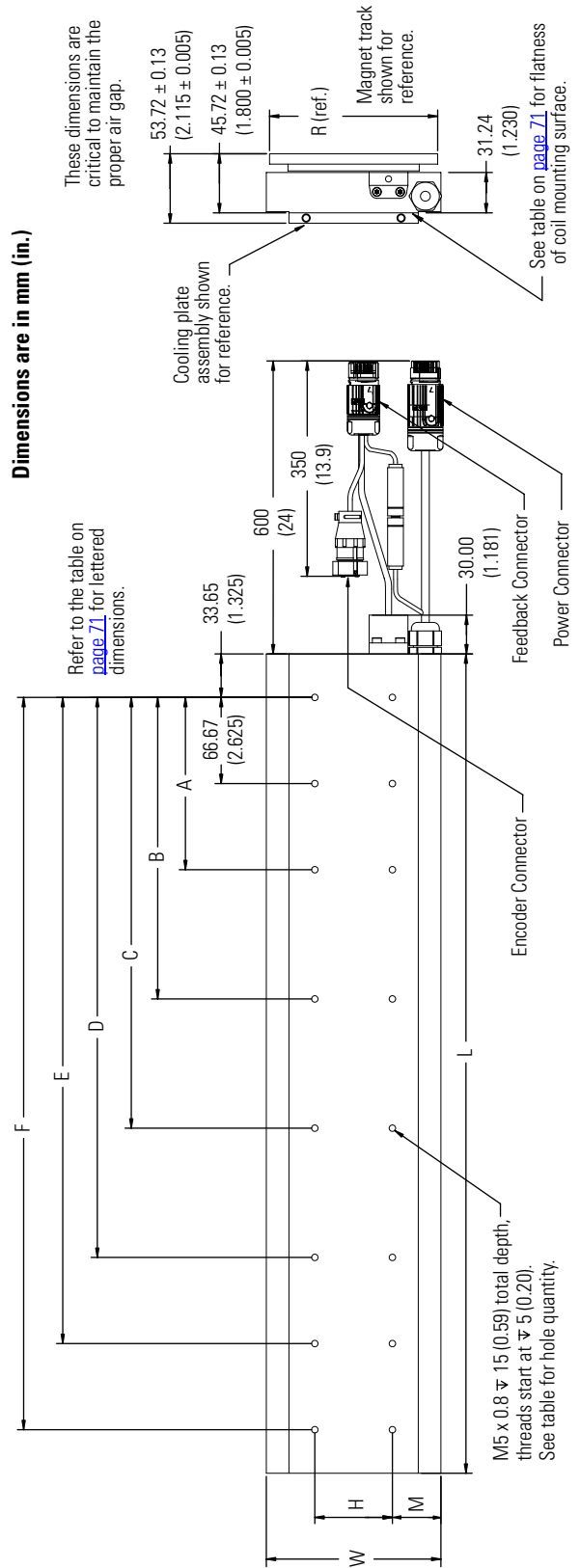

LDC-Series Iron Core Linear Motor Coil Dimensions (LDC-C030/050/075/100xxx-xHT-xx)

Cat. No.	L mm (in.)	W ⁽¹⁾ mm (in.)	A mm (in.)	B mm (in.)	C mm (in.)	D mm (in.)	E mm (in.)	F mm (in.)	H mm (in.)	M mm (in.)	R mm (in.)	Hole Qty
LDC-C030100-DHT-xx	134.0 (5.28)	65.00 (2.559)	-	-	-	-	-	-	15.00 (0.591)	25.00 (0.984)	60.00 (2.362)	4
LDC-C030200-xHT-xx	234.0 (9.21)		100.00 (3.937)	166.67 (6.562)	-	-	-	-	-	-	-	8
LDC-C050100-DHT-xx	134.0 (5.28)	85.00 (3.346)	-	-	-	-	-	-	25.00 (0.984)	30.00 (1.181)	80.00 (3.150)	4
LDC-C050200-xHT-xx	234.0 (9.21)		100.00 (3.937)	166.67 (6.562)	-	-	-	-	-	-	-	8
LDC-C050300-xHT-xx	334.0 (13.15)		133.33 (5.249)	200.00 (7.874)	266.67 (10.499)	-	-	-	-	-	-	10
LDC-C075200-xHT-xx	234.0 (9.21)		100.00 (3.937)	166.67 (6.562)	-	-	-	-	-	-	-	8
LDC-C075300-xHT-xx	334.0 (13.15)	110.00 (4.331)	133.33 (5.249)	200.00 (7.874)	266.67 (10.499)	-	-	-	40.00 (1.575)	35.00 (1.378)	105.00 (4.134)	10
LDC-C075400-xHT-xx	434.0 (17.09)		133.33 (5.249)	233.33 (9.186)	300.00 (11.811)	366.67 (14.436)	-	-	-	-	-	12
LDC-C100300-xHT-xx	334.0 (13.15)		133.33 (5.249)	200.00 (7.874)	266.67 (10.499)	-	-	-	-	-	-	10
LDC-C100400-xHT-xx	434.0 (17.09)	135.00 (5.315)	133.33 (5.249)	233.33 (9.186)	300.00 (11.811)	366.67 (14.436)	-	-	60.00 (2.362)	37.50 (1.476)	130.00 (5.118)	12
LDC-C100600-xHT-xx	634.0 (25.31)		133.33 (5.249)	233.33 (9.186)	333.33 (13.123)	433.33 (17.060)	500.00 (19.686)	566.66 (22.310)	-	-	-	16

(1) Tolerance for W dimension is +1.00 mm (+0.039 in.), -0.00 mm (-0.000 in.)

Cat. No.	Power Cable Gauge ⁽¹⁾ mm ² (AWG)	Cat. No.	Flatness mm/300 x 300 (in./12 x 12)
LDC-C030xxx-xHT-xx		LDC-C030xxx-xHT-xx	
LDC-C050xxx-xHT-xx		LDC-C050100-DHT-xx	0.25 (0.01)
LDC-C075xxx-xHT-xx	0.75 (18)	LDC-C050200-xHT-xx	
LDC-C100300-xHT-xx		LDC-C050300-xHT-xx	0.38 (0.15)
LDC-C100400-xHT-xx		LDC-C075200-xHT-xx	0.25 (0.01)
LDC-C100600-DHT-xx	1.5 (16)	LDC-C075300-xHT-xx	0.38 (0.015)
LDC-C100600-EHT-xx	0.75 (18)	LDC-C075400-xHT-xx	0.64 (0.25)
		LDC-C100300-xHT-xx	0.38 (0.015)
		LDC-C100400-xHT-xx	0.64 (0.25)
		LDC-C100600-xHT-xx	0.89 (0.035)

(1) Refer to [Cable Specifications on page 73](#) for additional cable specifications.

LDC-Series Iron Core Linear Motor Coil Dimensions (LDC-C0150xxx-xHT20) with Flying Leads

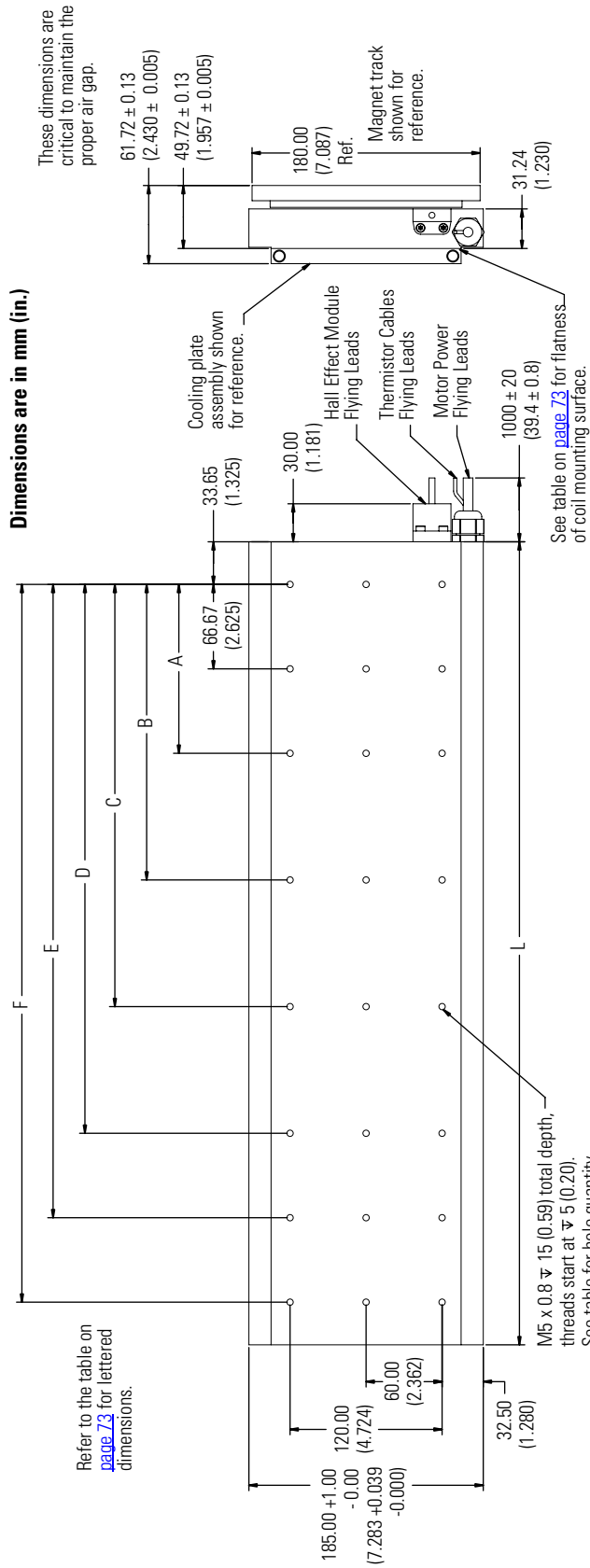

LDC-Series Iron Core Linear Motor Coil Dimensions (LDC-C150xxx-xHT11) with Connectors

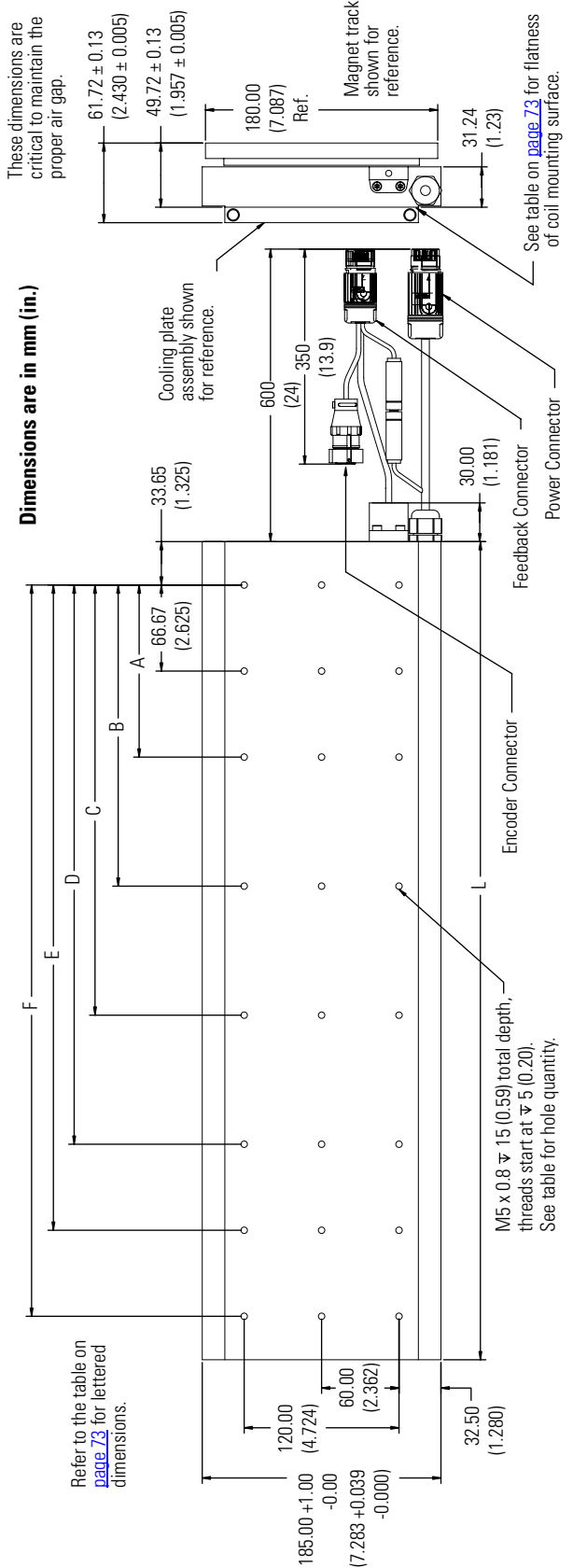

LDC-Series Iron Core Linear Motor Coil Dimensions (LDC-C150xxx-xHTxx)

Cat. No.	L mm (in.)	A mm (in.)	B mm (in.)	C mm (in.)	D mm (in.)	E mm (in.)	F mm (in.)	Hole Qty
LDC-C150400-xHTxx	434.0 (17.09)	133.33 (5.249)	233.33 (9.186)	300.00 (11.811)	366.67 (14.436)	—	—	18
LDC-C150600-xHTxx	634.0 (25.31)	133.33 (5.249)	233.33 (9.186)	333.33 (13.123)	433.33 (17.060)	500.00 (19.686)	566.66 (22.310)	24

Cable Specifications

Cable (1)	Conductors	Gauge mm ² (AWG)	Shield Type	Cable Dia. mm (in.)	Static Bend Radius mm (in.)	Cat. No.	Power Cable Gauge mm ² (AWG)	Flatness mm/300 x 300 (in./12 x 12)
Power (2)	4	0.75 (18)	Braid	7.0 (0.28)	18.0 (0.70)	LDC-C150400-xHTxx	0.82 (18)	0.64 (0.025)
Power (2)	4	1.5 (16)	Braid	8.0 (0.32)	17.0 (0.67)	LDC-C150600-DHTxx		
Power (2)	4	0.50 (20)	Braid	6.4 (0.25)	17.0 (0.67)	LDC-C150600-EHTxx	1.31 (16)	0.89 (0.035)
Thermistor	2	0.14 (26)	None	4.0 (0.16)	10.0 (0.40)			
Hall Module	6	0.25 (24)	Foil	5.0 (0.20)	15.0 (0.59)			

(1) All cables are non-flex.

(2) Power cable specification is dependent on coil used. See [Power Cable Gauge](#) column in the tables on [page 71](#) and [73](#).

Magnet Track Dimensions

LDC-Series Iron Core Linear Motor Coil Magnet Track Dimensions

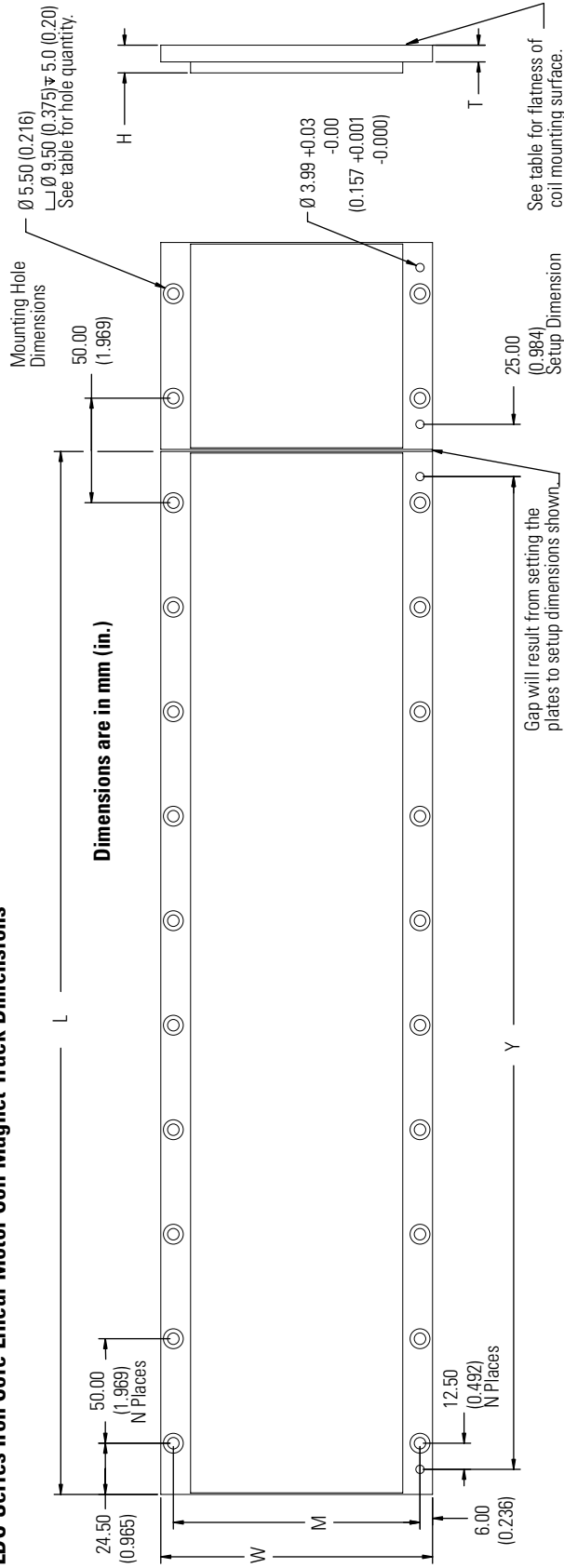

Cat. No.	L (1) mm (in.)	Y (2) mm (in.)	W mm (in.)	M mm (in.)	H (3) mm (in.)	T mm (in.)	N	Hole Qty	Flatness (4) mm/300 x 300 (in./12 x 12)
LDC-M030100			60.0 (2.36)	48.00 (1.890)					0.06 (0.002)
LDC-M050100			80.0 (3.15)	68.00 (2.677)	13.26 (0.522)	8.00 (0.315)	1	4	
LDC-M075100	99.0 (3.90)	75.00 (2.953)	105.0 (4.13)	93.00 (3.661)					0.13 (0.005)
LDC-M100100			130.0 (5.12)	118.00 (4.646)					
LDC-M150100			180.0 (7.09)	168.00 (6.614)	17.26 (0.680)	12.00 (0.472)			
LDC-M030500			60.0 (2.36)	48.00 (1.890)					0.50 (0.20)
LDC-M050500			80.0 (3.15)	68.00 (2.677)	13.26 (0.522)	8.00 (0.315)	9	20	
LDC-M075500	499.0 (19.65)	475.00 (18.70)	105.0 (4.13)	93.00 (3.661)					
LDC-M100500			130.0 (5.12)	118.00 (4.646)					0.90 (0.035)
LDC-M150500			180.0 (7.09)	168.00 (6.614)	17.26 (0.680)	12.00 (0.472)			

(1) Tolerance for L dimension is ± 0.25 mm (± 0.010 in.)
 (2) Tolerance for Y dimension is ± 0.08 mm (± 0.003 in.)
 (3) Tolerance for H dimension is ± 0.16 mm (± 0.006 in.)
 (4) Specified flatness is in the free state.

Cooling Plate Dimensions

LDC-Series Iron Core Linear Motor Coil Cooling Plate Dimensions (LDC-030/050/075/100-xxx-CP)

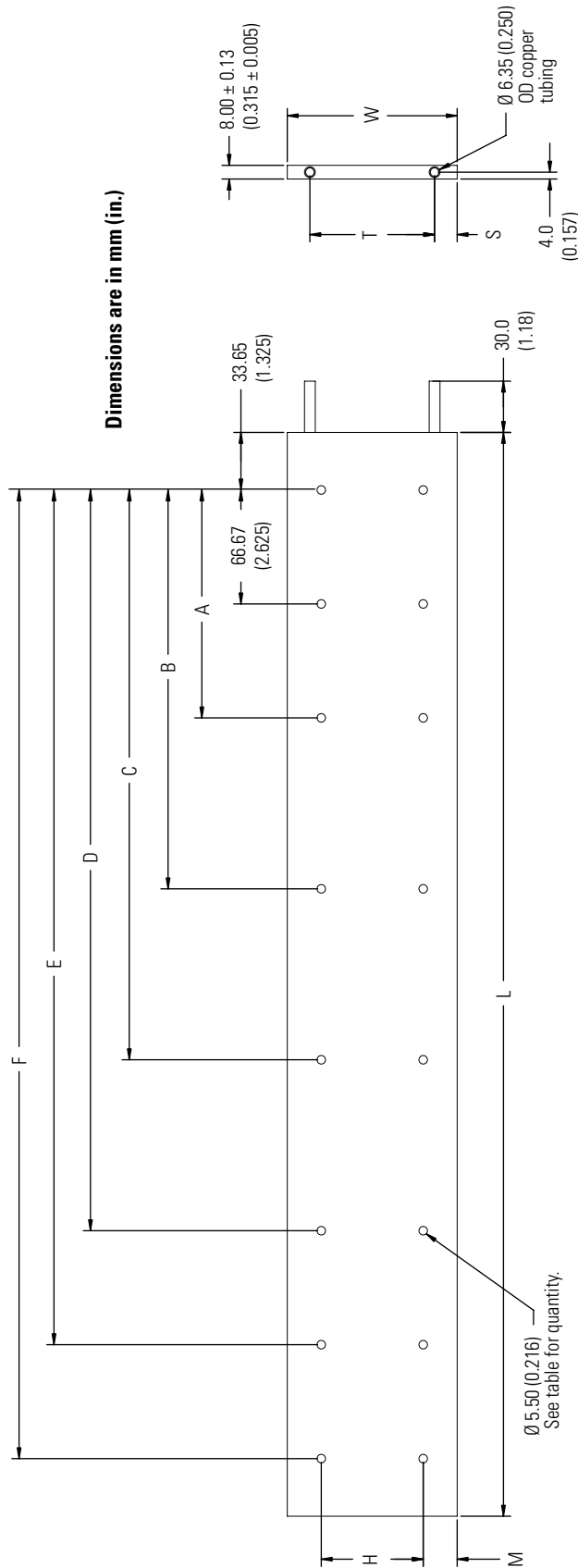

Cat. No.	L mm (in.)	W mm (in.)	A mm (in.)	B mm (in.)	C mm (in.)	D mm (in.)	E mm (in.)	F mm (in.)	H mm (in.)	M mm (in.)	T mm (in.)	S mm (in.)	Hole Qty
LDC-030-100-CP	134.0 (5.28)	38.00 (1.496)	-	-	-	-	-	-	15.00 (0.591)	11.50 (0.453)	27.5 (1.08)	5.25 (0.207)	4
LDC-030-200-CP	234.0 (9.21)	-	100.00 (3.937)	166.67 (6.562)	-	-	-	-	-	-	-	-	8
LCC-050-100-CP	134.0 (5.28)	50.00 (1.969)	-	-	-	-	-	-	25.00 (0.984)	12.50 (0.492)	38.1 (1.50)	5.95 (0.234)	4
LDC-050-200-CP	234.0 (9.21)	-	100.00 (3.937)	166.67 (6.562)	-	-	-	-	-	-	-	-	8
LCC-050-300-CP	334.0 (13.15)	-	133.33 (5.249)	200.00 (7.874)	266.67 (10.499)	-	-	-	-	-	-	-	10
LDC-075-200-CP	234.0 (9.21)	75.00 (2.953)	100.00 (3.937)	166.67 (6.562)	-	-	-	-	40.00 (1.575)	17.50 (0.689)	50.8 (2.00)	12.10 (0.476)	8
LDC-075-300-CP	334.0 (13.15)	-	133.33 (5.249)	200.00 (7.874)	266.67 (10.499)	-	-	-	-	-	-	-	10
LDC-075-400-CP	434.0 (17.09)	-	133.33 (5.249)	233.33 (9.186)	300.00 (11.811)	366.67 (14.436)	-	-	-	-	-	-	12
LDC-100-300-CP	334.0 (13.15)	100.00 (3.937)	133.33 (5.249)	200.00 (7.874)	266.67 (10.499)	-	-	-	60.00 (2.362)	20.00 (0.787)	73.4 (2.89)	13.30 (0.524)	10
LDC-100-400-CP	434.0 (17.09)	-	133.33 (5.249)	233.33 (9.186)	300.00 (11.811)	366.67 (14.436)	-	-	-	-	-	-	12
LDC-100-600-CP	634.0 (25.31)	-	133.33 (5.249)	233.33 (9.186)	333.33 (13.123)	433.33 (17.060)	500.00 (19.686)	566.66 (22.310)	-	-	-	-	16

LDC-Series Iron Core Linear Motor Coil Cooling Plate Dimensions (LDC-150-xxx-CP)

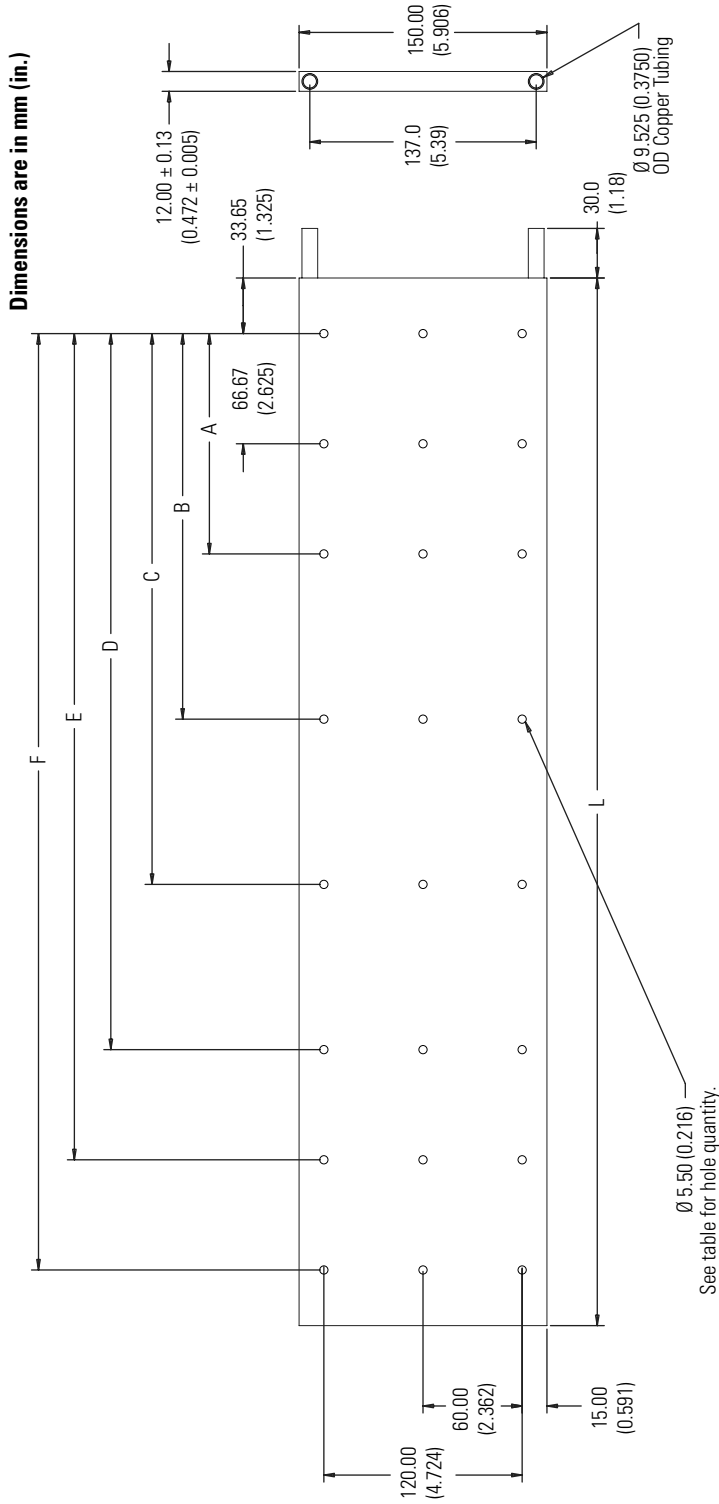

Cat. No.	L mm (in.)	A mm (in.)	B mm (in.)	C mm (in.)	D mm (in.)	E mm (in.)	F mm (in.)	Hole Qty
LDC-150-400-CP	434.0 (17.09)	133.33 (5.249)	233.33 (9.186)	300.00 (11.811)	366.67 (14.436)	-	-	18
LDC-150-600-CP	634.0 (25.31)	133.33 (5.249)	233.33 (9.186)	333.33 (13.123)	433.33 (17.060)	500.00 (19.686)	566.66 (22.310)	24

Interconnect Diagrams

Introduction

This appendix provides wiring examples to assist you in wiring an LDC-Series linear motor to an Allen-Bradley drive.

Topic	Page
Kinetix 6000 or Kinetix 2000 Drives and LDC-xxxxxxx-xHT11 Linear Motor with a TTL Encoder	78
Kinetix 6000 or Kinetix 2000 Drives and LDC-xxxxxxx-xHT11 Linear Motor with a Sin/Cos Encoder	79
Kinetix 6000 or Kinetix 2000 Drives and LDC-xxxxxxx-xHT20 Linear Motor with a TTL Encoder	80
Kinetix 6000 or Kinetix 2000 Drives and LDC-xxxxxxx-xHT20 Linear Motor with a Sin/Cos Encoder	81
Ultra3000 Drives and LDC-xxxxxxx-xHT11 Linear Motor with a TTL Encoder	82
Ultra3000 Drives and LDC-xxxxxxx-xHT11 Linear Motor with a Sin/Cos Encoder	83
Ultra3000 Drives and LDC-xxxxxxx-xHT20 Linear Motor with a TTL Encoder	84
Ultra3000 Drives and LDC-xxxxxxx-xHT20 Linear Motor with a Sin/Cos Encoder	85

Wiring Examples

These notes apply to the wiring examples on the pages that follow.

Note	Information
1	Use cable shield clamp in order to meet CE requirements. No external connection to ground is required.
2	For motor cable specifications, refer to the Kinetix Motion Control Selection Guide, publication GMC-SG001 .
3	When using Sin/Cos encoder with Kinetix 6000 drives refer to Appendix C on page 87 .

Wiring Example for Kinetix 6000 or Kinetix 2000 Drives and LDC-xxxxxxx-xHT11 Linear Motor with a TTL Encoder

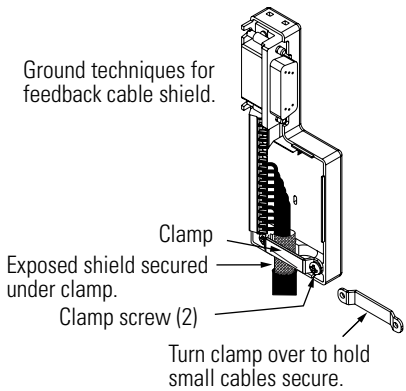
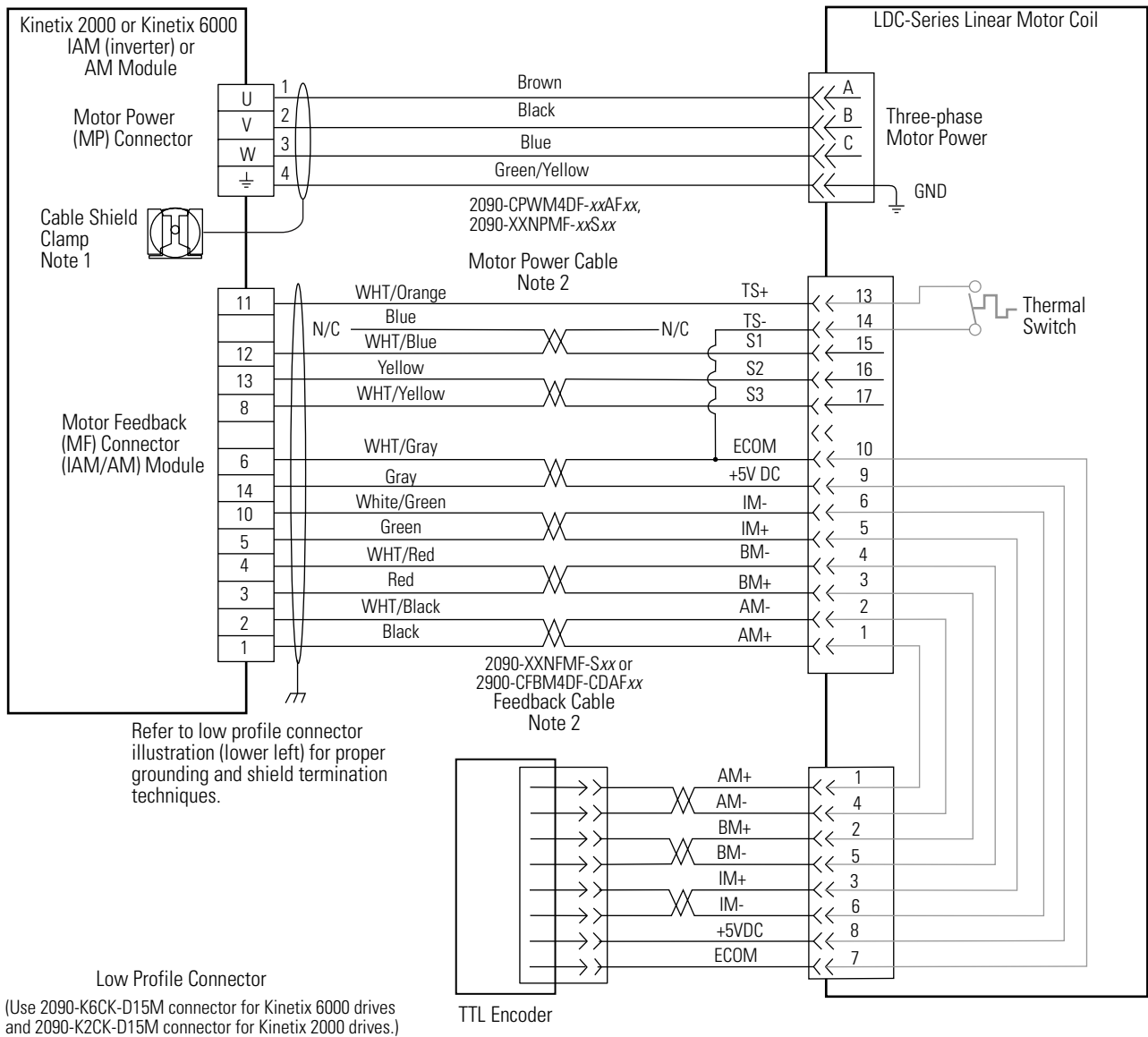

Wiring Example for Kinetix 6000 or Kinetix 2000 Drives and LDC-xxxxxxx-xHT11 Linear Motor with a Sin/Cos Encoder

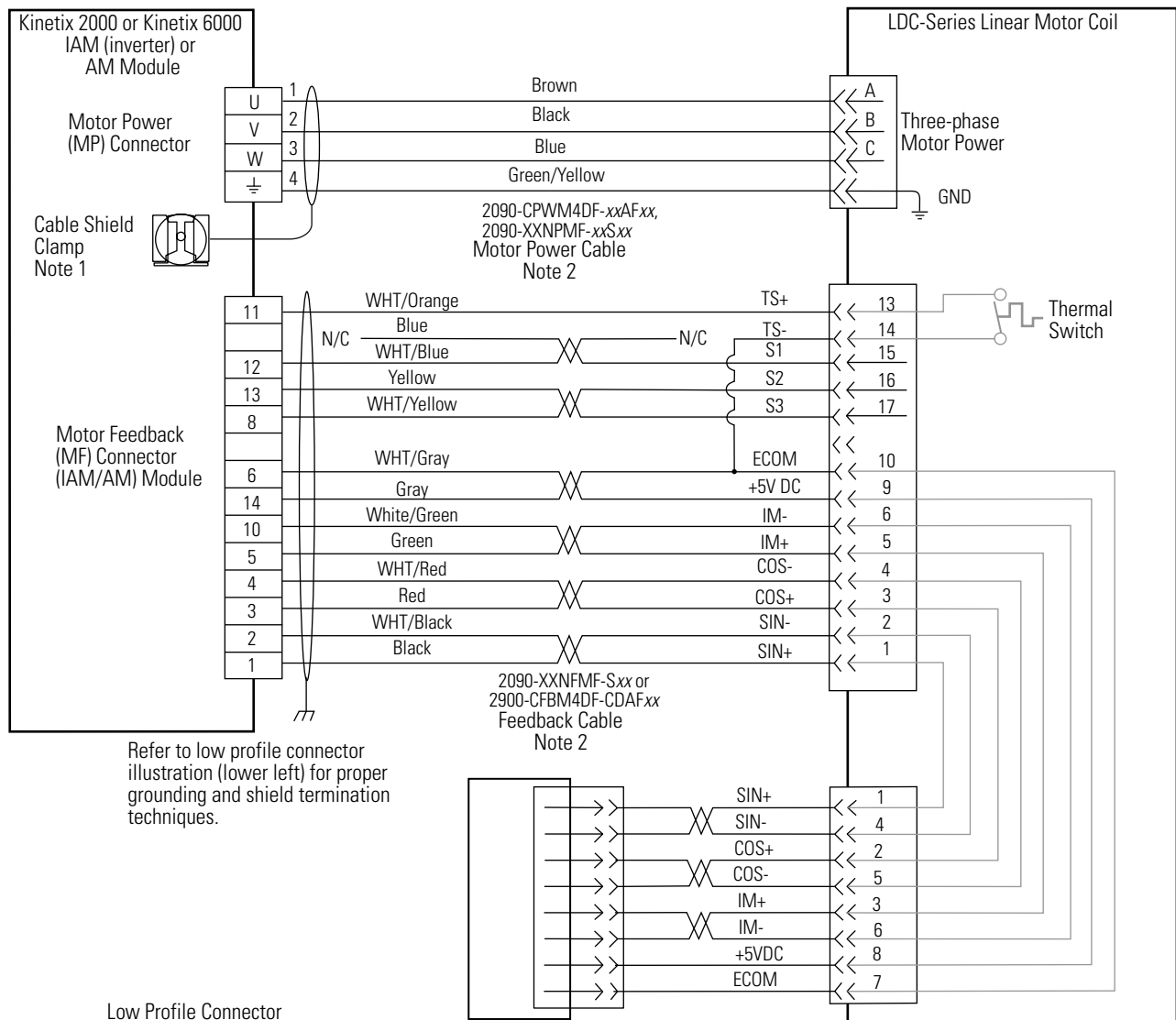

Refer to low profile connector illustration (lower left) for proper grounding and shield termination techniques.

Low Profile Connector

(Use 2090-K6CK-D15M connector for Kinetix 6000 drives and 2090-K2CK-D15M connector for Kinetix 2000 drives.)

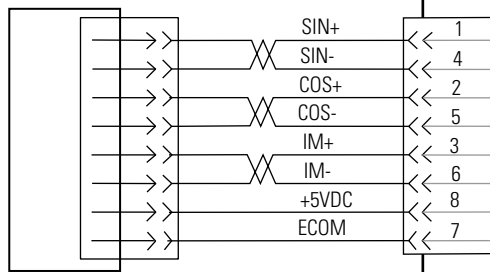

Sin/Cos Encoder
Note 3

Ground techniques for feedback cable shield.

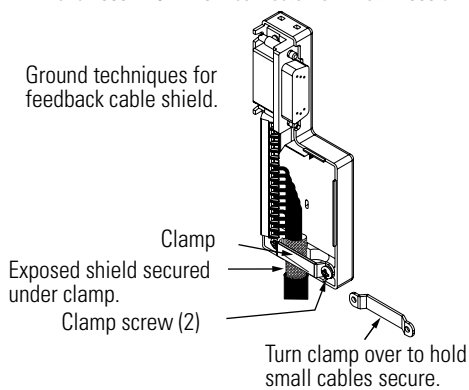

Wiring Example for Kinetix 6000 or Kinetix 2000 Drives and LDC-xxxxxxx-xHT20 Linear Motor with a TTL Encoder

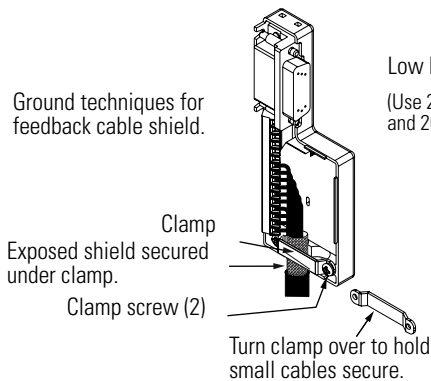
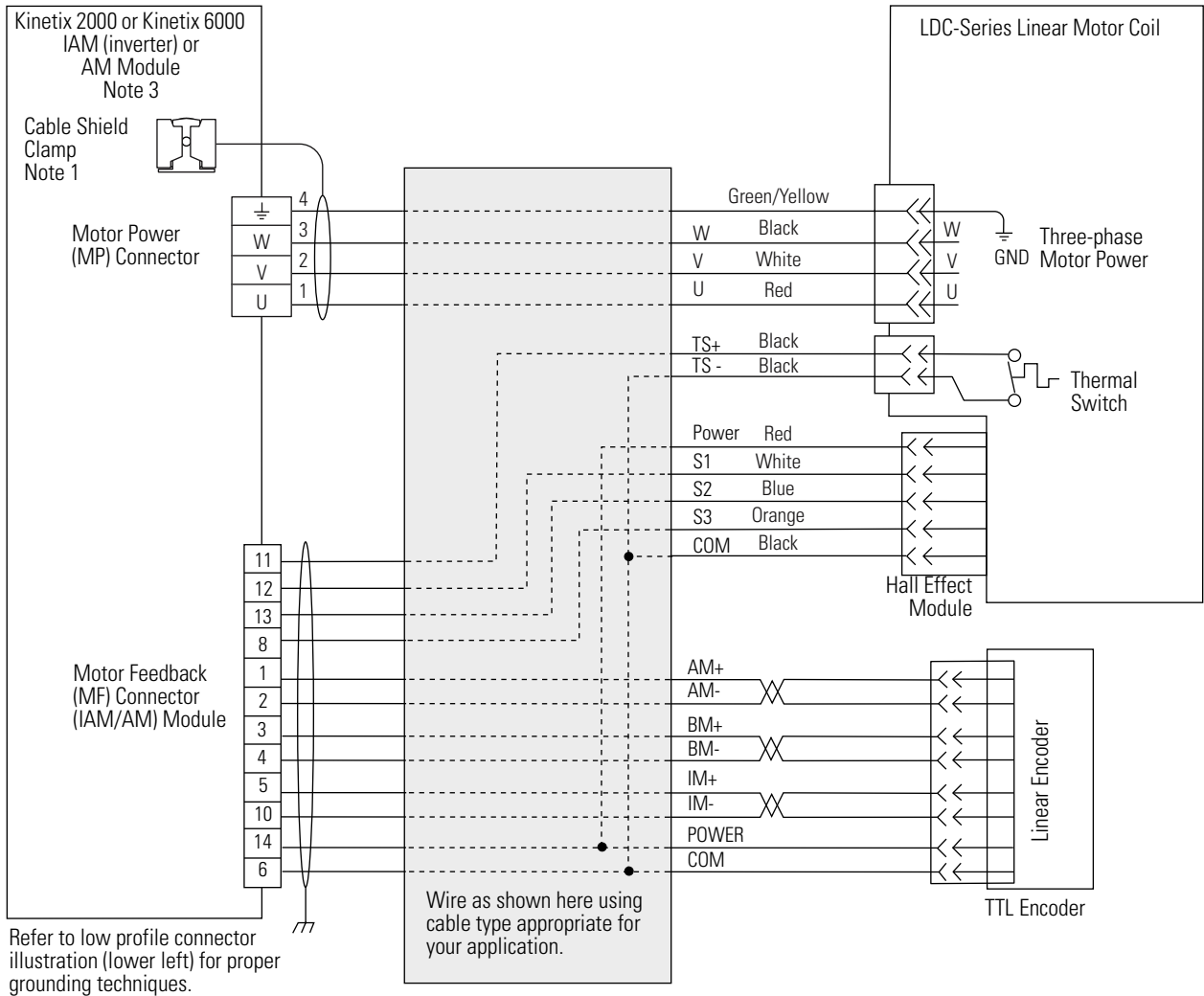

Wiring Example for Kinetix 6000 or Kinetix 2000 Drives and LDC-xxxxxxx-xHT20 Linear Motor with a Sin/Cos Encoder

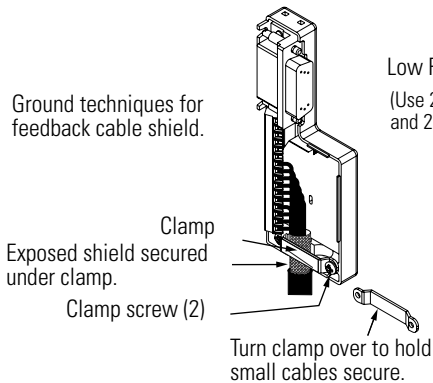
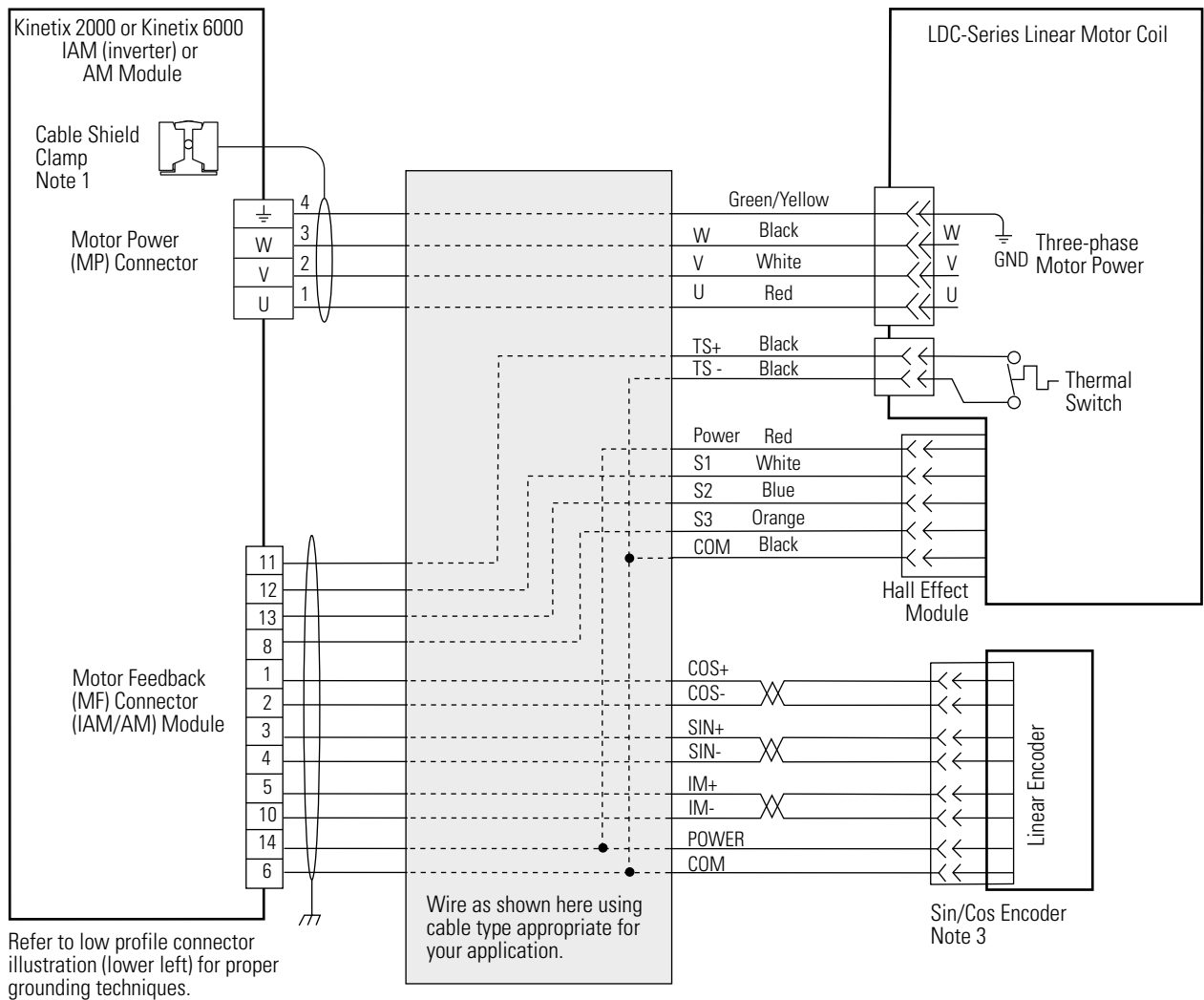

Wiring Example for Ultra3000 Drive and LDC-xxxxxxx-xHT11 Linear Motor with a TTL Encoder

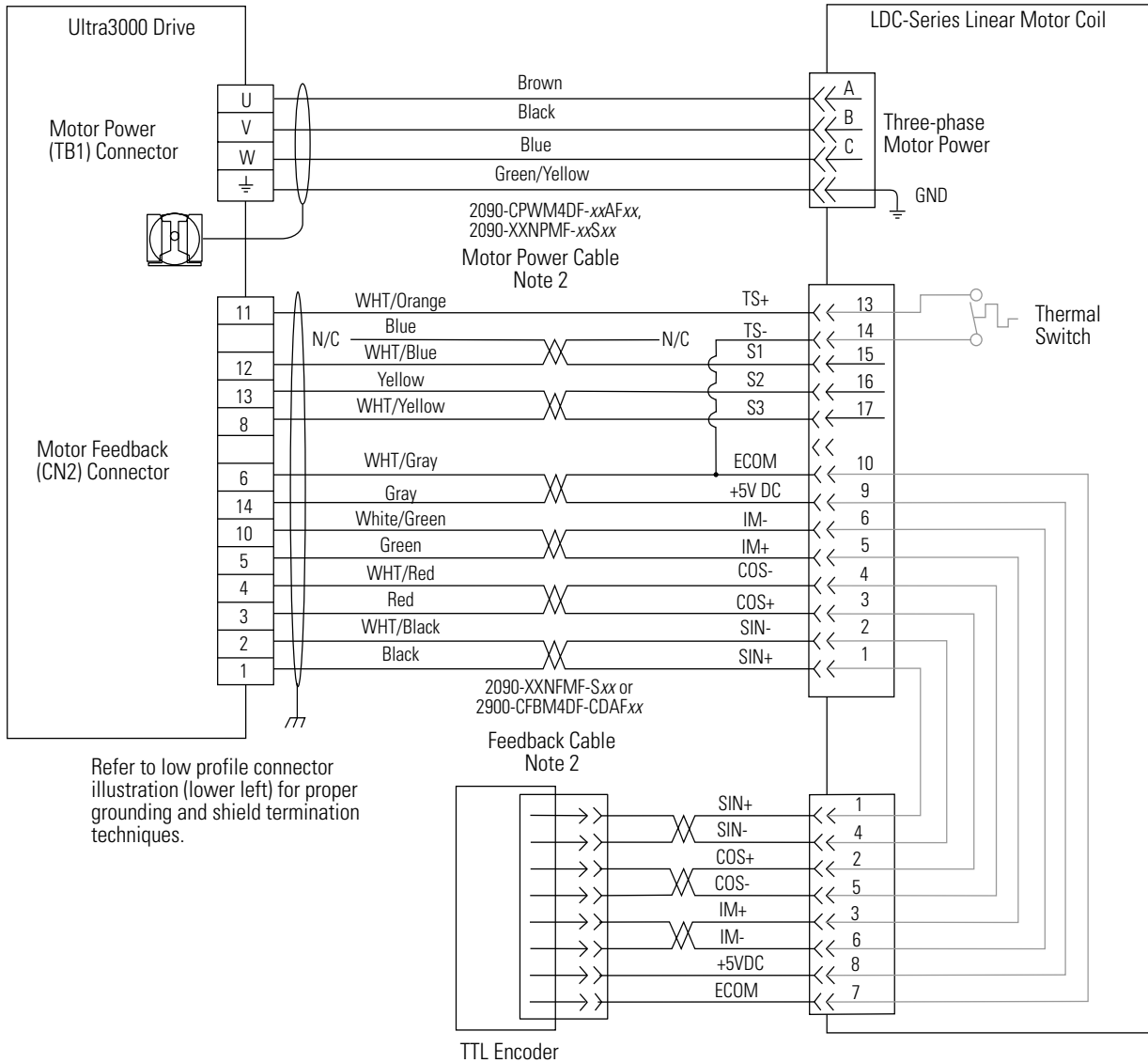

Refer to low profile connector illustration (lower left) for proper grounding and shield termination techniques.

Ground techniques for feedback cable shield.

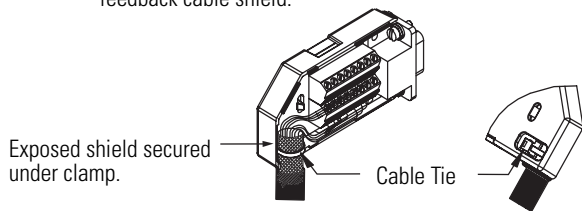

2090-UXBB-DM15 Motor Feed Breakout Board

Wiring Example for Ultra3000 Drive and LDC-xxxxxxx-xHT11 Linear Motor with a Sin/Cos Encoder

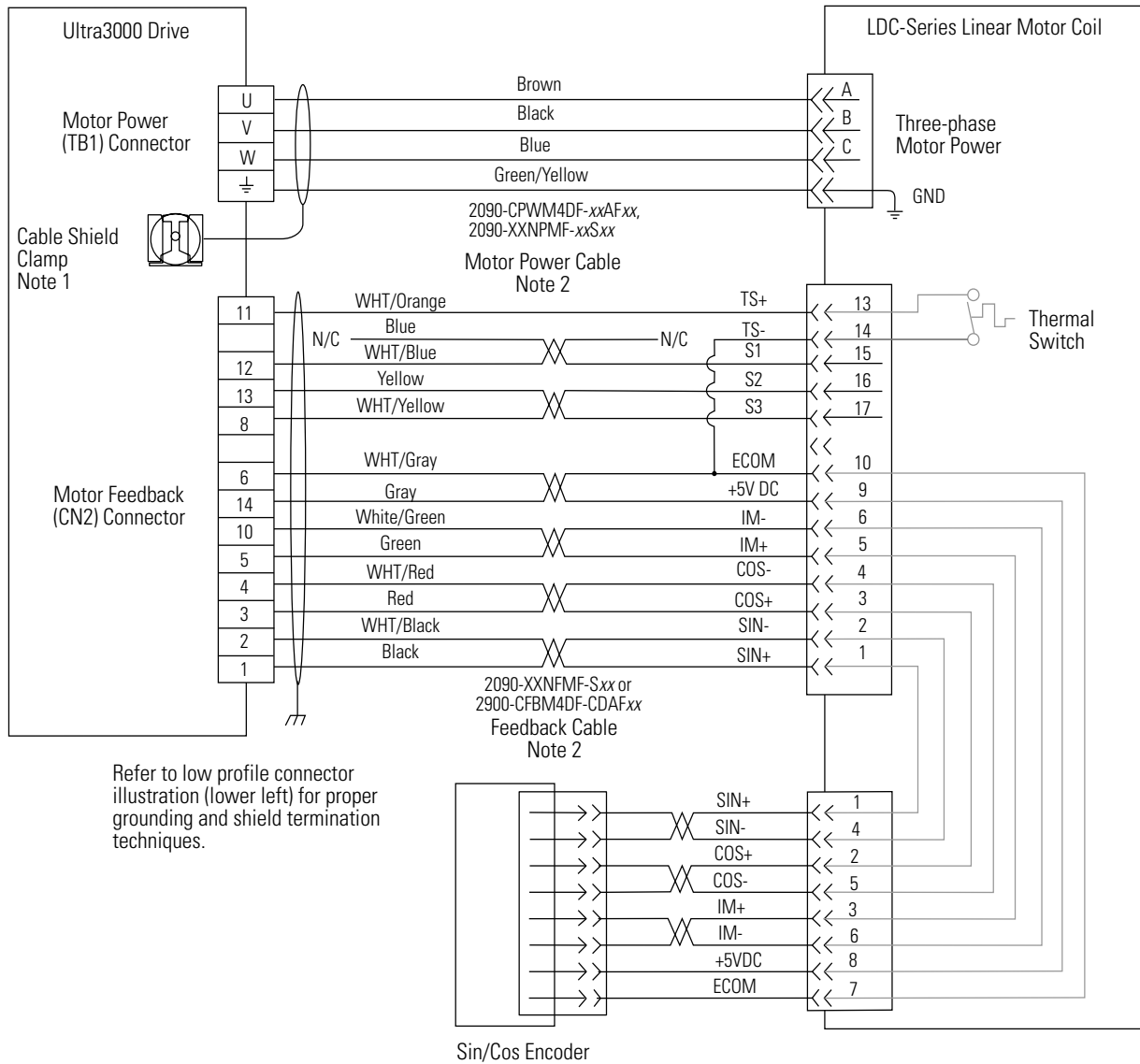

Ground techniques for feedback cable shield.

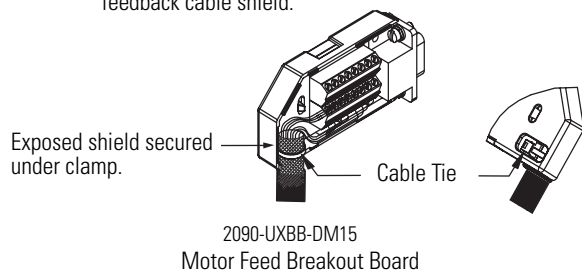

Wiring Example for Ultra3000 Drive and LDC-xxxxxxx-xHT20 Linear Motor with a TTL Encoder

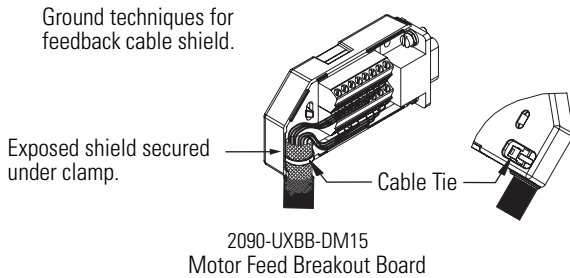
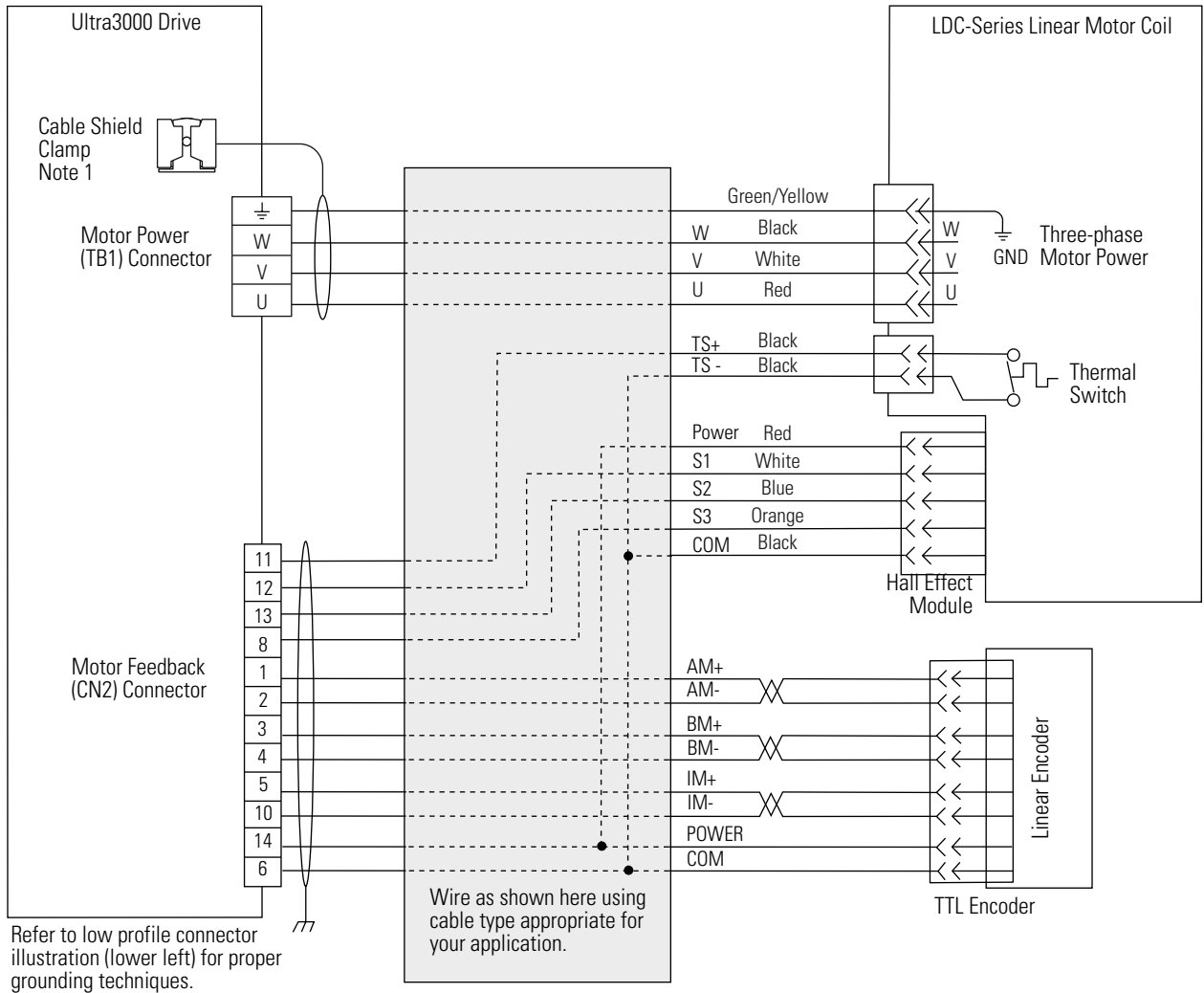

Wiring Example for Ultra3000 Drive and LDC-xxxxxxx-xHT20 Linear Motor with a Sin/Cos Encoder

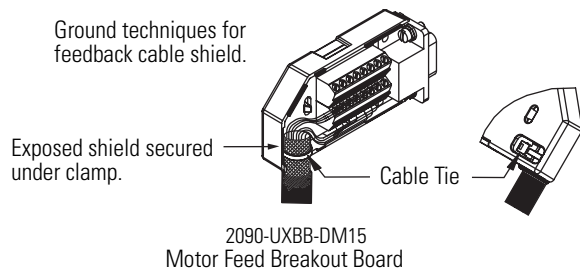
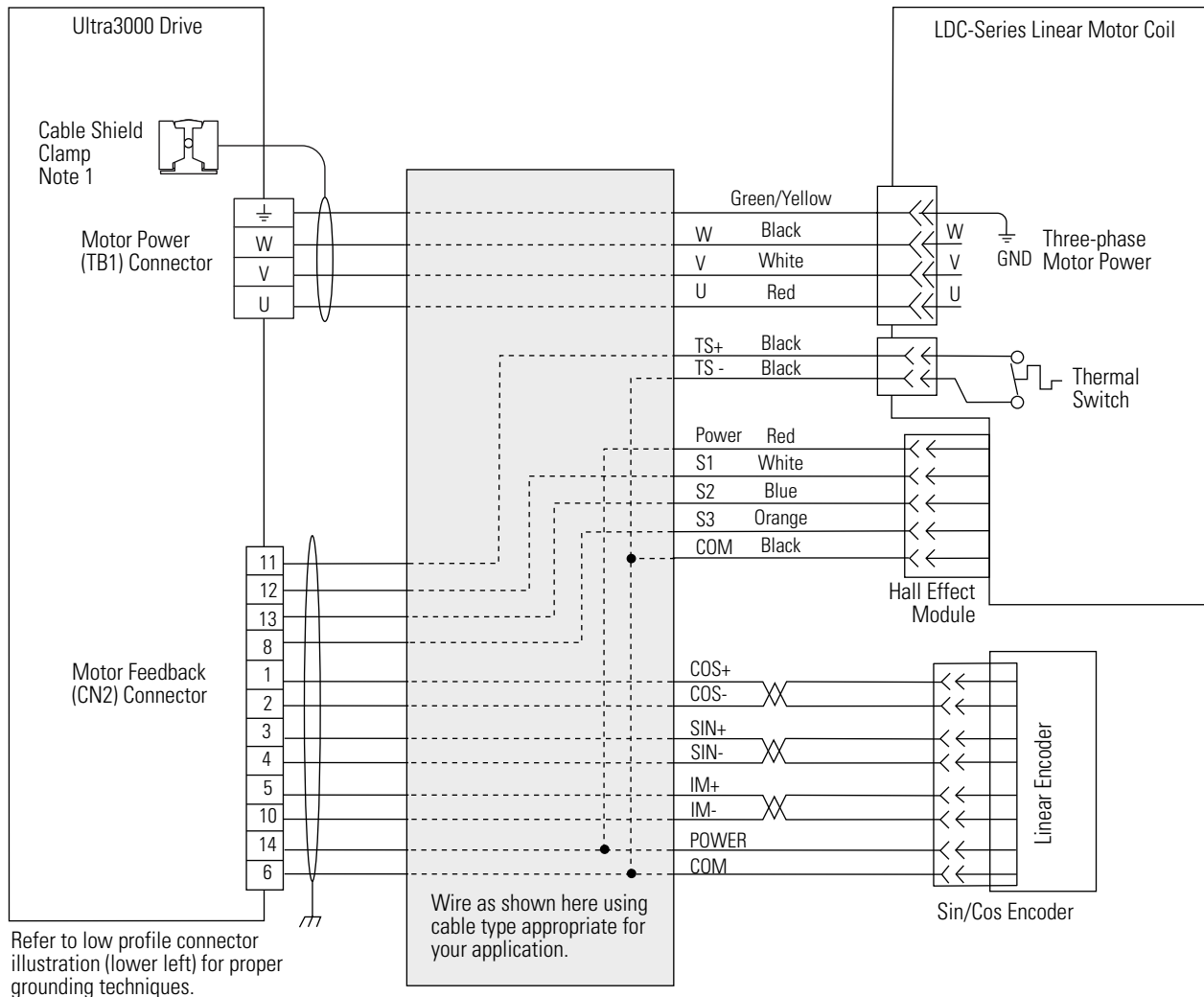

Notes:

Sin/Cos Linear Encoder and Kinetix 6000 Drives

Introduction

This appendix guides you through commissioning a linear motor with a Sin/Cos 1V peak-to-peak output linear encoder.

Topic	Page
Kinetix 6000 Drive Feedback Connection	87
Encoder Counting Direction	88
Set Up the Axis Properties	88

Kinetix 6000 Drive Feedback Connection

For robust operation when interfacing your Sin/Cos 1V peak-to-peak differential output linear encoder to a Kinetix 6000 drive, you should terminate the sine and cosine signals as follows.

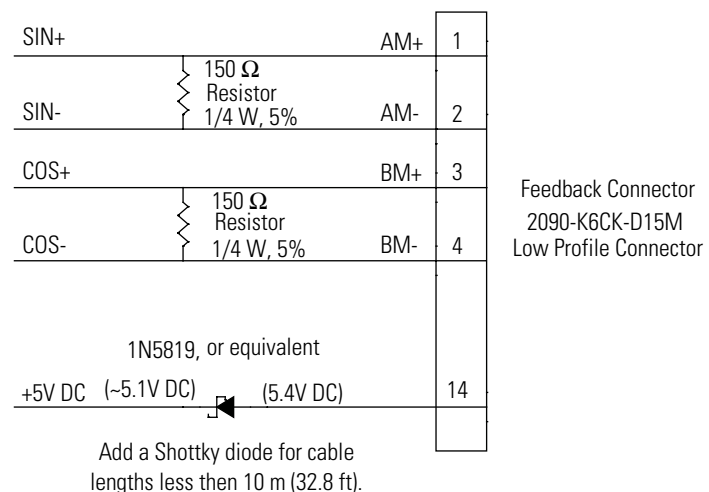

For systems where the cable length is less than 10 m (32.8 ft), the encoder power supply from the Kinetix 6000 drive feedback connector should be dropped from its nominal 5.4...5.1V DC volts with the addition of a Shottky Diode, see schematic.

Encoder Counting Direction Normally, the encoder signals will output sine-leads-cosine (AM leads BM) when the linear encoder head is moving towards its cable, relative to the encoder scale. SERCOS drives count this in a **negative** direction.

Set Up the Axis Properties When installing a Sin/Cos linear encoder, setup the Axis Property tabs by doing the following.

1. Click the Motor Feedback tab.

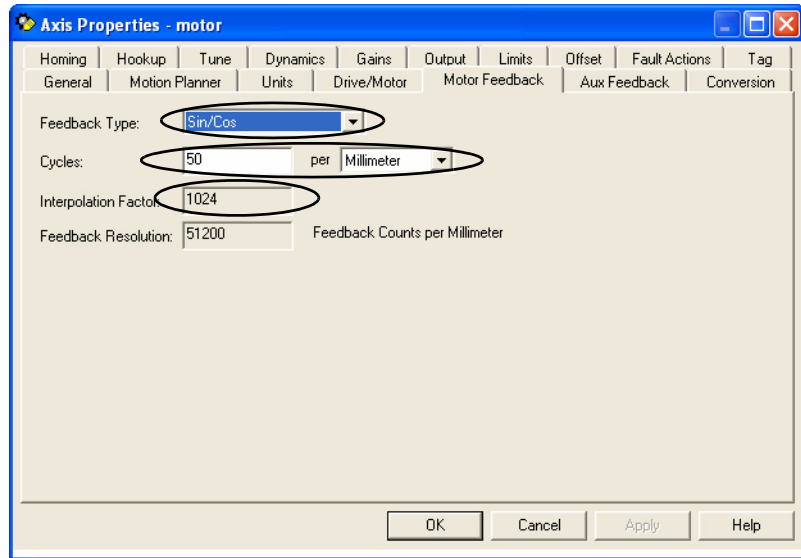

2. Enter the following parameters.

Parameter	Value	Comment
Feedback Type	Sin/Cos	—
Cycles	25 per Millimeter	For 40 μ pitch encoder scale.
	50 per Millimeter	For 20 μ pitch encoder scale.
Interpolation Factor	1024	—

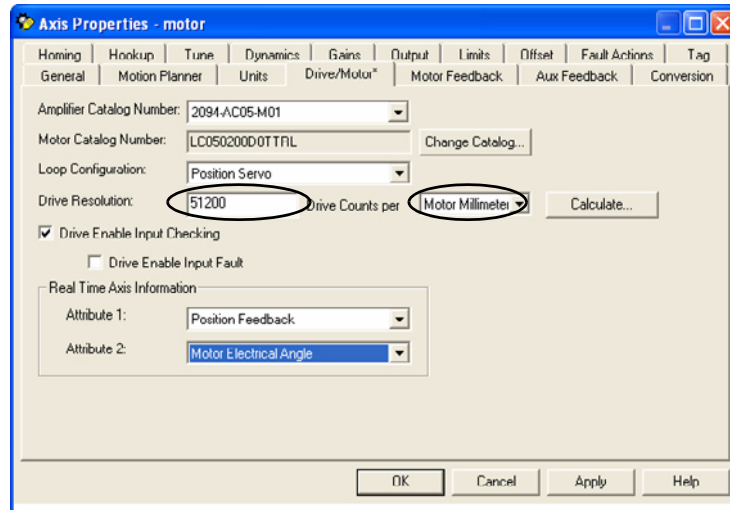
3. Click the Drive/Motor tab.**4.** Enter the following parameters.

Parameter	Value	Comment
Driver Resolution	25600	For 40 μ pitch encoder scale.
	51200	For 20 μ pitch encoder scale.
Drive Counts per	Motor Millimeter	–

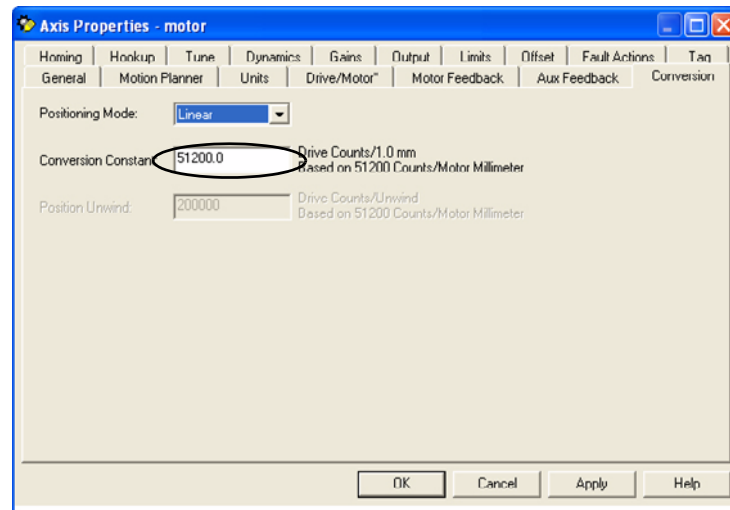
5. Click the Conversion tab.**6.** Enter the following parameters.

Parameter	Value	Comment
Driver Resolution	25600	For 40 μ pitch encoder scale.
	51200	For 20 μ pitch encoder scale.

Notes:

A

air gap 18
alignment tool 22
aluminum straight edge 22
attraction 22
**automatic implantable cardioverter
defibrillator (AICD)** 9

B

beryllium copper 22
bulk head connector kit 35
bumper 12, 18
burn hazard 12

C

carriage 19
coil 17
coil power connector 31
commission
 Kinetix 2000 drive 46
 Kinetix 6000 drive 46
 Ultra-3000 drive 51
common specification 60
connector 31
 encoder 17, 33
 feedback 17, 32
 power 17, 31
 PTC thermistor 17, 32, 33

D

description
 motor 17
design consideration
 air gap 18
 bumper 18
 carriage design, heat sink 19
 end of travel bumper 12
 linear encoder 19
direction 53

E

encoder 35
 resolution 54
encoder connector 33
encoder connector kit 35
encoder sin/cos 87
end of travel bumpers 12
end of travel impact 12

end stop 18
ESD components
 Hall effect ESD 12

F

feedback connector 32
ferrous material 22
firmware revision 44
flying leads 35

H

Hall effect module 17
heat sink 19
 max temperature 12

I

installation 21
 firmware 44
 software 44
interconnect diagrams
 wiring example notes 77

L

label
 identification 10
large impacts 12
linear encoder 19

M

magnet track 17, 22
maintenance 19
max. speed 13
motion analyzer version 44
motor
 database 44
 direction 53
 storage 19
mounting
 multiple motors 39
 power cable 31

N

non-magnetic 22

P

performance 19

phase alignment

- two motors 39

pinout

- coil power 31
- encoder 33
- feedback 32
- power connector 31
- PTC thermistor 32, 33

power connector 17, 31**procedure**

- cleaning magnet track 19
- connections 35
- install magnet track 22
- power connection 31
- verify encoder resolution 54
- verify motor wiring 54

PTC thermistor connector 32**R****reference documents**

- A-B automation glossary 7
- drive manuals 7
- SERCOS interface 7

RSLogix software screen

- conversion 50
- drive/motor 46
- motor feedback 47
- units 49

S**safety**

- burn 9
- hazardous voltage 9
- labels 9
- strong magnets 9
- sudden motion 12

safety label, location of 10**SERCOS Drive** 87**setup**

- Kinetix 2000 drive 46
- Kinetix 6000 drive 46
- Ultra-3000 drive 51

shipping

- air freight restriction 11
- dangerous goods declaration 11
- form 902 instructions 11

shock absorber 18**software**

- required version 44

spacing

- two motors 39

specifications

- common 60

storage 19**T****tandem motors** 39**temperature**

- max heat sink 12

tools 22**torque**

- magnet track 26, 29

V**verify**

- direction 53
- motor wiring 54
- resolution 54

W**warning**

- air freight restrictions 11
- automatic implantable cardioverter
defibrillator (AICD) 9
- powerful forces 9

wiring 35**wiring diagram** 78

- connectorized
 - Sin/Cos encoder 79, 83
 - TTL encoder 78, 82
- flying lead
 - Sin/Cos encoder 81, 84, 85
 - TTL encoder 80

Notes:

Notes:

Notes:

Rockwell Automation Support

Rockwell Automation provides technical information on the Web to assist you in using its products. At <http://support.rockwellautomation.com>, you can find technical manuals, a knowledge base of FAQs, technical and application notes, sample code and links to software service packs, and a MySupport feature that you can customize to make the best use of these tools.

For an additional level of technical phone support for installation, configuration, and troubleshooting, we offer TechConnect support programs. For more information, contact your local distributor or Rockwell Automation representative, or visit <http://support.rockwellautomation.com>.

Installation Assistance

If you experience a problem within the first 24 hours of installation, please review the information that's contained in this manual. You can also contact a special Customer Support number for initial help in getting your product up and running.

United States	1.440.646.3434 Monday – Friday, 8 a.m. – 5 p.m. EST
Outside United States	Please contact your local Rockwell Automation representative for any technical support issues.

New Product Satisfaction Return

Rockwell Automation tests all of its products to ensure that they are fully operational when shipped from the manufacturing facility. However, if your product is not functioning and needs to be returned, follow these procedures.

United States	Contact your distributor. You must provide a Customer Support case number (call the phone number above to obtain one) to your distributor in order to complete the return process.
Outside United States	Please contact your local Rockwell Automation representative for the return procedure.

www.rockwellautomation.com

Power, Control and Information Solutions Headquarters

Americas: Rockwell Automation, 1201 South Second Street, Milwaukee, WI 53204-2496 USA, Tel: (1) 414.382.2000, Fax: (1) 414.382.4444

Europe/Middle East/Africa: Rockwell Automation, Vorstlaan/Boulevard du Souverain 36, 1170 Brussels, Belgium, Tel: (32) 2 663 0600, Fax: (32) 2 663 0640

Asia Pacific: Rockwell Automation, Level 14, Core F, Cyberport 3, 100 Cyberport Road, Hong Kong, Tel: (852) 2887 4788, Fax: (852) 2508 1846