

SPECIFICATIONS:

1. MOTOR INFORMATION

MOTOR TYPE: VARIABLE SPEED AC
 FRAME SIZE: RDL1613Y
 RATING: 41.8 KW
 VOLTAGE: 400
 ENCLOSURE: TOTALLY ENCLOSED IP54
 MOUNTING: FLANGE (350mm BOLT CIRCLE)
 COOLING: BLOWER COOLED IC416
 DRIVE METHOD: COUPLED OR BELTED
 ACCESSORIES: ENCODER

2. CONTINUOUS STALL TORQUE: 271 Nm
 MAX AT 155°C WINDING TEMPERATURE, IN A 40°C AMBIENT

3. OPERATING SPEED: 1500 BASE SPEED / 3000 RPM MAX.

4. 1024 SINUSOID/REV ENCODER, WITH MULTI-TURN ABSOLUTE POSITION DATA

5. FOR ADDITIONAL SPECIFICATIONS SEE 10000000099

6. SHAFT HEIGHT WILL NOT BE EXCEEDED SHIMS UP TO 0.5 MM IN THICKNESS USUALLY REQUIRED FOR COUPLED OR GEARED MACHINES.

7. SHAFT EXTENSIONS ARE ACCORDING TO DIN 748, TOLERANCES ARE BASED ON THE ISA FITTING SYSTEM USING k6 FOR DIAMETERS UP TO 50MM AND m6 FOR DIAMETERS ABOVE.

8. MAX SHAFT TIR .06 [0.002] MAX FACE TIR .13 [0.005]

9. MOTOR WEIGHT 275 KG. [606 LBS] (MAY VARY 15%)

BLOWER CONNECTION	
STAR CONNECTION	
LEAD	400 VOLTS
U1	R
V1	S
W1	T
U2	
V2	
W2	
GRN/YEL	GROUND
DELTA CONNECTION	
LEAD	200 VOLTS
U1	R
W2	S
V1	
U2	
V1	T
V2	
GRN/YEL	GROUND

PIN-OUT ENCODER CONNECTOR	
PIN	FUNCTION
A	SIN +
B	SIN -
C	COS +
D	COS -
E	DATA +
F	DATA -
G-M	-
N	+9 VDC
P	COM
R	TS +
S	TS -
T-V	-

MOTOR CONNECTION TERMINAL BOX	
LEAD	SOURCE
U1	L1
V1	L2
W1	L3
GREEN	GROUND

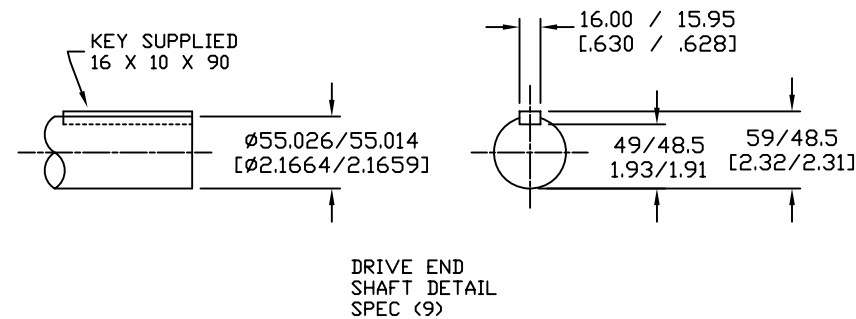

SUPPLIER PART NUMBER: L16M5251

NOTE: ALL DRAWING MODIFICATIONS REQUIRE CUSTOMER APPROVAL

REFERENCES		DESCRIPTION	CAD DOCUMENT
VERSION/ CHANGE NUMBER	TOLERANCES UNLESS OTHERWISE SPECIFIED	HPK-E1613C-MA42AA,ESM	
	DO NOT SCALE DRAWING DIMENSIONS ARE IN MILLIMETERS WITH INCHES REFERENCED EX) UNTOLERANCED DIMENSIONS ARE REFERENCED THIRD ANGLE PROJECTION	Rockwell Automation	Allen-Bradley
		DR. SDR	DATE 06-23-06 SHEET 1 OF 1
		DXF FILE AVAILABLE	DWG. SIZE B DOCUMENT NUMBER 10000000121