

SPECIFICATIONS:

1. MOTOR INFORMATION

MOTOR TYPE: VARIABLE SPEED AC  
 FRAME SIZE: RDL1609Y  
 RATING: 48.5 KW  
 VOLTAGE: 400  
 ENCLOSURE: TOTALLY ENCLOSED IP54  
 MOUNTING: FLANGE (350mm BOLT CIRCLE)  
 COOLING: BLOWER COOLED IC416  
 DRIVE METHOD: COUPLED OR BELTED  
 ACCESSORIES: ENCODER

2. CONTINUOUS STALL TORQUE: 156 Nm  
 MAX AT 155°C WINDING TEMPERATURE, IN A 40°C AMBIENT

3. OPERATING SPEED: 3000 BASE SPEED / 5000 RPM MAX.

4. 1024 SINUSOID/REV ENCODER, WITH SINGLE-TURN ABSOLUTE POSITION DATA

5. FOR ADDITIONAL SPECIFICATIONS SEE 10000000108

6. SHAFT HEIGHT WILL NOT BE EXCEEDED  
 SHIMS UP TO 0.5 MM IN THICKNESS USUALLY REQUIRED FOR COUPLED OR GEARED MACHINES.

7. SHAFT EXTENSIONS ARE ACCORDING TO DIN 748, TOLERANCES ARE BASED ON THE ISA FITTING SYSTEM USING k6 FOR DIAMETERS UP TO 50MM AND m6 FOR DIAMETERS ABOVE.

8. MAX SHAFT TIR .06 [0.002]  
 MAX FACE TIR .13 [0.005]

9. MOTOR WEIGHT 213 KG. [469 LBS] (MAY VARY 15%)

BLOWER CONNECTION	
STAR CONNECTION	
LEAD	400 VOLTS
U1	R
V1	S
W1	T
U2	
V2	
W2	
GRN/YEL	GROUND
DELTA CONNECTION	
LEAD	200 VOLTS
U1	R
W2	
V1	S
U2	
W1	T
V2	
GRN/YEL	GROUND

PIN-OUT ENCODER CONNECTOR	
PIN	FUNCTION
A	SIN +
B	SIN -
C	COS +
D	COS -
E	DATA +
F	DATA -
G-M	-
N	+9 VDC
P	COM
R	TS +
S	TS -
T-V	-

MOTOR CONNECTION TERMINAL BOX	
LEAD	SOURCE
U1	L1
V1	L2
W1	L3
GREEN	GROUND

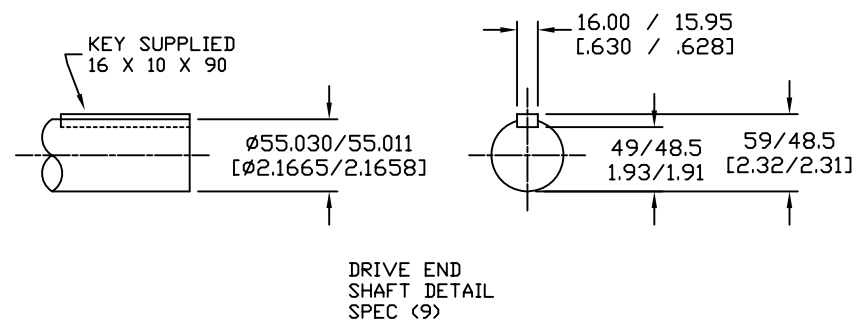

SUPPLIER PART NUMBER: L16M5247

NOTE: ALL DRAWING MODIFICATIONS REQUIRE CUSTOMER APPROVAL

REFERENCES		DESCRIPTION	CAD DOCUMENT
VERSION/ CHANGE NUMBER	TOLERANCES UNLESS OTHERWISE SPECIFIED	HPK-E1609E-SA42AA,ESM	
	DO NOT SCALE DRAWING DIMENSIONS ARE IN MILLIMETERS WITH INCHES REFERENCED EX) UNTOLERANCED DIMENSIONS ARE REFERENCED THIRD ANGLE PROJECTION	<b>Rockwell Automation</b>	Allen-Bradley
		DR. --	DATE --
		SHEET 1 OF 1	
		DWG. SIZE B	DOCUMENT NUMBER 10000000155