

## **XM-441 Expansion Relay Module**

Catalog Number 1440-REX00-04RD

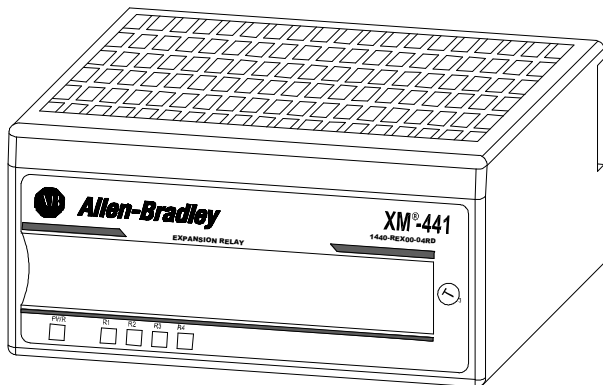

<b>For information about</b>	<b>See page</b>
Important User Information	2
Safety Approvals	4
Mounting the Module	7
Module Indicators	9
Agency Certification	10
Specifications	11

### Important User Information

Solid state equipment has operational characteristics differing from those of electromechanical equipment. Safety Guidelines for the Application, Installation and Maintenance of Solid State Controls (Publication SGI-1.1 available from your local Rockwell Automation sales office or online at <http://literature.rockwellautomation.com>) describes some important differences between solid state equipment and hard-wired electromechanical devices. Because of this difference, and also because of the wide variety of uses for solid state equipment, all persons responsible for applying this equipment must satisfy themselves that each intended application of this equipment is acceptable.





In no event will Rockwell Automation, Inc. be responsible or liable for indirect or consequential damages resulting from the use or application of this equipment.

The examples and diagrams in this manual are included solely for illustrative purposes. Because of the many variables and requirements associated with any particular installation, Rockwell Automation, Inc. cannot assume responsibility or liability for actual use based on the examples and diagrams.

No patent liability is assumed by Rockwell Automation, Inc. with respect to use of information, circuits, equipment, or software described in this manual.

Reproduction of the contents of this manual, in whole or in part, without written permission of Rockwell Automation, Inc., is prohibited.

Throughout this manual, when necessary, we use notes to make you aware of safety considerations.

 <b>WARNING</b>	Identifies information about practices or circumstances that can cause an explosion in a hazardous environment, which may lead to personal injury or death, property damage, or economic loss.
 <b>IMPORTANT</b>	Identifies information that is critical for successful application and understanding of the product.
 <b>ATTENTION</b>	Identifies information about practices or circumstances that can lead to personal injury or death, property damage, or economic loss. Attentions help you identify a hazard, avoid a hazard and recognize the consequences.
 <b>SHOCK HAZARD</b>	Labels may be on or inside the equipment (for example, drive or motor) to alert people that dangerous voltage may be present.
 <b>BURN HAZARD</b>	Labels may be on or inside the equipment (for example, drive or motor) to alert people that surfaces may reach dangerous temperatures.

**ATTENTION****Environment and Enclosure**

This equipment is supplied as “open type” equipment. It must be mounted within an enclosure that is suitably designed for those specific environmental conditions that will be present, and appropriately designed to prevent personal injury resulting from accessibility to live parts. The interior of the enclosure must be accessible only by the use of a tool. Subsequent sections of this publication may contain additional information regarding specific enclosure type ratings that are required to comply with certain product safety certifications.

See NEMA Standards publication 250 and IEC publication 60529, as applicable, for explanations of the degrees of protection provided by different types of enclosures.

**ATTENTION****Preventing Electrostatic Discharge**

This equipment is sensitive to electrostatic discharge, which can cause internal damage and affect normal operation. Follow these guidelines when you handle this equipment:

- Touch a grounded object to discharge potential static.
- Wear an approved grounding wrist strap.
- Do not touch connectors or pins on component boards.
- Do not touch circuit components inside the equipment.
- If available, use a static-safe workstation.
- When not in use, keep modules in appropriate static-safe packaging.

**ATTENTION**

This module is designed so you can **remove and insert it under power**. However, when you remove or insert the module with power applied, I/O attached to the module can change states due to its input/output signal changing conditions. Take special care when using this feature.

**WARNING**

When you insert or remove the module while power is on, an electrical arc can occur. This could cause an explosion in hazardous location installations. Be sure that power is removed or the area is nonhazardous before proceeding.

## 4 XM-441 Expansion Relay Module

### WARNING



If you connect or disconnect the serial cable with power applied to the module or the serial device on the other end of the cable, an electrical arc can occur. This could cause an explosion in hazardous location installations. Be sure that power is removed or the area is nonhazardous before proceeding.

### IMPORTANT

Install the overlay slide label to protect serial connector and electronics when the serial port is not in use.

## Safety Approvals

### The following information applies when operating this equipment in hazardous locations.

Products marked "CL I, DIV 2, GP A, B, C, D" are suitable for use in Class I Division 2 Groups A, B, C, D, Hazardous Locations and nonhazardous locations only. Each product is supplied with markings on the rating nameplate indicating the hazardous location temperature code. When combining products within a system, the most adverse temperature code (lowest "T" number) may be used to help determine the overall temperature code of the system. Combinations of equipment in your system are subject to investigation by the local Authority Having Jurisdiction at the time of installation.

### Informations sur l'utilisation de cet équipement en environnements dangereux.

Les produits marqués "CL I, DIV 2, GP A, B, C, D" ne conviennent qu'à une utilisation en environnements de Classe I Division 2 Groupes A, B, C, D dangereux et non dangereux. Chaque produit est livré avec des marquages sur sa plaque d'identification qui indiquent le code de température pour les environnements dangereux. Lorsque plusieurs produits sont combinés dans un système, le code de température le plus défavorable (code de température le plus faible) peut être utilisé pour déterminer le code de température global du système. Les combinaisons d'équipements dans le système sont sujettes à inspection par les autorités locales qualifiées au moment de l'installation.

### WARNING



### EXPLOSION HAZARD -

- Do not disconnect equipment unless power has been removed or the area is known to be nonhazardous.
- Do not disconnect connections to this equipment unless power has been removed or the area is known to be nonhazardous. Secure any external connections that mate to this equipment by using screws, sliding latches, threaded connectors, or other means provided with this product.
- Substitution of components may impair suitability for Class I, Division 2.
- If this product contains batteries, they must only be changed in an area known to be nonhazardous.

### AVERTISSEMENT



### RISQUE D'EXPLOSION -

- Couper le courant ou s'assurer que l'environnement est classé non dangereux avant de débrancher l'équipement.
- Couper le courant ou s'assurer que l'environnement est classé non dangereux avant de débrancher les connecteurs. Fixer tous les connecteurs externes reliés à cet équipement à l'aide de vis, loquets coulissants, connecteurs filetés ou autres moyens fournis avec ce produit.
- La substitution de composants peut rendre cet équipement inadapté à une utilisation en environnement de Classe I, Division 2.
- S'assurer que l'environnement est classé non dangereux avant de changer les piles.

**IMPORTANT**

Wiring to or from this device, which enters or leaves the system enclosure, must utilize wiring methods suitable for Class I, Division 2 Hazardous Locations, as appropriate for the installation in accordance with the product drawings as indicated in the following table.

Model	Catalog Number	Haz Location Drawings*	
		w/o Barriers	w/ Barriers
XM-120	1440-VST0201RA	48178-HAZ	48179-HAZ
XM-121	1440-VLF0201RA		
XM-122	1440-VSE0201RA		
XM-123	1440-VAD0201RA		
XM-160	1440-VDRS0600RH	51263-HAZ	51264-HAZ
XM-161	1440-VDRS0606RH		
XM-162	1440-VDRP0600RH		
XM-220	1440-SPD0201RB	48640-HAZ	48641-HAZ
XM-320	1440-TPS0201RB	48238-HAZ	48239-HAZ
XM-360	1440-TPR0600RE	48295-HAZ	48299-HAZ
XM-361	1440-TUN0600RE		
XM-362	1440-TTC0600RE		
XM-440	1440-RMA0004RC	48240-HAZ	N/A
XM-441	1440-REX0004RD	48241-HAZ	N/A
XM-442	1440-REX0304RG	48642-HAZ	N/A

\* Drawings are available on the included CD

## 6 XM-441 Expansion Relay Module

---

### European Zone 2 Certification

---

If appropriately marked, this equipment is intended for use in potentially explosive atmospheres as defined by European Union Directive 94/9/CE.

Compliance with the Essential Health and Safety Requirements has been assured by compliance with EN 60079-0:2009, EN 60079-15:2010, and EN 60079-11:2007.

---

#### **IMPORTANT**

Observe the following additional Zone 2 certification requirements:

- This equipment is not resistant to sunlight or other sources of UV radiation.
  - The secondary of a current transformer shall not be open-circuited.
  - The marking "ALCR" is to be considered "as applicable" to individual products.
  - Equipment of lesser Enclosure Type Rating must be installed in an enclosure providing at least IP54 protection when applied in Class I, Zone 2 environments.
  - This equipment must be powered by energy limited associated equipment as defined in EN 60079 when applied in Class I, Zone 2 environments.
  - Provision shall be made external to the equipment, to provide the transient protection device to be set at a level not exceeding 140% of the peak rated voltage when applied in Class I, LCIE 04 ATEX 6084 X Zone 2 environments.
-

## Mounting the Module

The XM-441 mounts on a XM-943 terminal base unit, Cat. No. 1440-TB-D. We recommend that you mount the module after you have connected the wiring on the terminal base unit. Refer to the *XM-943 Expansion Relay Terminal Base Installation Instructions* or the Module User Guide for wiring information.

**ATTENTION**

The XM-441 is compatible only with the XM-943 terminal base unit. The keyswitch on the terminal base unit should be at position 3 for the XM-441 module.

**Do not attempt to install XM-441 modules on other terminal base units. Do not change the position of the keyswitch after wiring the XM-943 terminal base unit.**

1. Make certain the keyswitch (A) on the terminal base unit (C) is at position 3 as required for the XM-441.

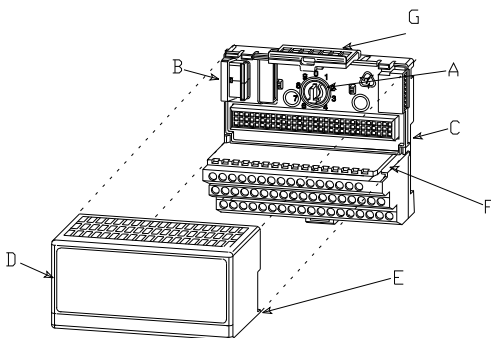

2. Make certain the side connector (B) is pushed all the way to the left. **You cannot install the module unless the connector is fully extended.**
3. Make sure that the pins on the bottom of the module are straight so they will align properly with the connector in the terminal base unit.

## 8 XM-441 Expansion Relay Module

---

4. Position the module (D) with its alignment bar (E) aligned with the groove (F) on the terminal base.
5. Press firmly and evenly to seat the module in the terminal base unit. The module is seated when the latching mechanism (G) is locked into the module.
6. Repeat the above steps to install the next module in its terminal base.



## Module Indicators

The XM-441 has a power status indicator (PWR) that is on when power is applied to the module and a status indicator for each relay (four in all). The indicators are located on top of the module.

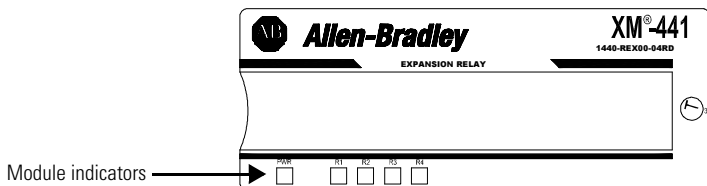

### Power (PWR) Status Indicator

Color	State	Description
No color	Off	No power applied to the module.
Green	Solid	Power applied to the module.

### Relay Indicators (4)

Color	State	Description
Red	Off	On-board relay is not activated.
	Solid	On-board relay is activated.

## Agency Certification (when product marked)

UL	UL Listed for Ordinary Locations
UL	UL Listed for Class I, Division 2 Group A, B, C, and D Hazardous Locations
CSA	CSA Certified Process Control Equipment
CSA	CSA Certified Process Control Equipment for Class I, Division 2 Group A, B, C, and D Hazardous Locations
EX <sup>1</sup>	European Union 94/9/EEC ATEX Directive, compliant with EN 60079; Potentially Explosive Atmospheres, Protection “n,” and Protection by intrinsic safety “i”
CE <sup>1</sup>	European Union 89/336/EEC EMC Directive
C-Tick <sup>1</sup>	Australian Radiocommunications Act, compliant with:  AS/NZS 2064, Industrial Emissions

1 See the Product Certification link at [www.rockwellautomation.com](http://www.rockwellautomation.com) for Declarations of Conformity, Certificates and other certification details.

## Specifications

The following table lists the technical specifications for the XM-441 module.

Product Feature	Specification
<p>Communications</p> <p style="text-align: right;">Side Connector</p>	<p>Communication interface is via the side connector between the XM-441 and the XM module mounted directly to the left of the XM-441.</p> <p>All XM measurement and relay modules include side connectors that allow interconnecting adjacent modules, thereby simplifying the external wiring requirements.</p> <p>The interconnect provides power, DeviceNet communication, and the circuits necessary to support expansion modules, such as the XM-441 Expansion Relay module.</p> <p><i>NOTE: DeviceNet protocol, which is not used by the XM-441, and primary power are passed through the module's terminal base to modules connected on either side of the XM-441.</i></p>
<p>Indicators</p> <p style="text-align: right;">5 LEDs</p>	<p>Module Power -green            Relay 1 - red            Relay 2 - red            Relay 3 - red            Relay 4 - red</p>
<p>Relays</p> <p style="text-align: right;">Number</p> <p style="text-align: right;">Contacts</p> <p style="text-align: right;">Failsafe</p>	<p>Four relays, two sets of contacts each - DPDT (2 Form C)</p> <p>250V AC, 50/60 Hz, 3 A Resistive</p> <p>Normally energized (failsafe), or            Normally de-energized (non-fail-safe)</p>

## 12 XM-441 Expansion Relay Module

<b>Product Feature</b>	<b>Specification</b>
These features are managed/controlled by the host XM module. Refer to the applicable XM module's specification for details on these features:	Latching Time Delay Voting Logic Reset Activation
Power  Module  Consumption  Heat Production	24V DC  120mA maximum  2.9 Watts (9.9 BTU/hr) maximum
Environmental  Operating Temperature  Storage Temperature  Relative Humidity  Conformal Coating	-20 to +65°C (-4 to +149°F)  -40 to +85°C (-40 to +185°F)  95% non-condensing  All printed circuit boards are conformally coated in accordance with IPC-A-610C.
Physical  Dimensions  Terminal Screw Torque	Height: 3.8 in (97 mm) Width: 3.7 in (94 mm) Depth: 3.7 in (94 mm)  7 pound-inches (0.6 Nm)

**Notes:**

## Rockwell Automation Support

Rockwell Automation provides technical information on the Web to assist you in using its products. At <http://www.rockwellautomation.com/support/>, you can find technical manuals, a knowledge base of FAQs, technical and application notes, sample code and links to software service packs, and a MySupport feature that you can customize to make the best use of these tools.

For an additional level of technical phone support for installation, configuration, and troubleshooting, we offer TechConnect support programs. For more information, contact your local distributor or Rockwell Automation representative, or visit <http://www.rockwellautomation.com/support/>.

## Installation Assistance

If you experience a problem within the first 24 hours of installation, please review the information that's contained in this manual. You can also contact a special Customer Support number for initial help in getting your product up and running.

United States or Canada	1.440.646.3434
Outside United States or Canada	Use the <a href="#">Worldwide Locator</a> at <a href="http://www.rockwellautomation.com/support/americas/phone_en.html">http://www.rockwellautomation.com/support/americas/phone_en.html</a> , or contact your local Rockwell Automation representative.

## New Product Satisfaction Return

Rockwell Automation tests all of its products to ensure that they are fully operational when shipped from the manufacturing facility. However, if your product is not functioning and needs to be returned, follow these procedures.

United States	Contact your distributor. You must provide a Customer Support case number (call the phone number above to obtain one) to your distributor to complete the return process.
Outside United States	Please contact your local Rockwell Automation representative for the return procedure.

## Documentation Feedback

Your comments will help us serve your documentation needs better. If you have any suggestions on how to improve this document, complete this form, publication [BA-DU002](#), available at <http://literature.rockwellautomation.com>.

XM is a registered trademark of Rockwell Automation Inc.

RSNetWorx for DeviceNet is a trademark of Rockwell Software, Inc.

DeviceNet is a trademark of the Open DeviceNet Vendor Association. Allen-Bradley, Rockwell Software, Rockwell Automation, and XM are trademarks of Rockwell Automation, Inc.

Trademarks not belonging to Rockwell Automation are property of their respective companies.

Rockwell Otomasyon Ticaret A.Ş., Kar Plaza İş Merkezi E Blok Kat:6 34752 İçerenköy, İstanbul, Tel: +90 (216) 5698400

[www.rockwellautomation.com](http://www.rockwellautomation.com)

### Power, Control and Information Solutions Headquarters

Americas: Rockwell Automation, 1201 South Second Street, Milwaukee, WI 53204 USA, Tel: (1) 414.382.2000, Fax: (1) 414.382.4444

Europe/Middle East/Africa: Rockwell Automation, Vorstlaan/Boulevard du Souverain 36, 1170 Brussels, Belgium, Tel: (32) 2 663 0600, Fax: (32) 2 663 0640

Asia Pacific: Rockwell Automation, Level 14, Core F, Cyberport 3, 100 Cyberport Road, Hong Kong, Tel: (852) 2887 4788, Fax: (852) 2508 1846

Publication ENMON-IN4411-EN-P - October 2012

PN-175832

Supersedes Publication ENMON-IN4411H-EN-P June 2011

Copyright © 2012 Rockwell Automation, Inc. All rights reserved. Printed in the U.S.A.