

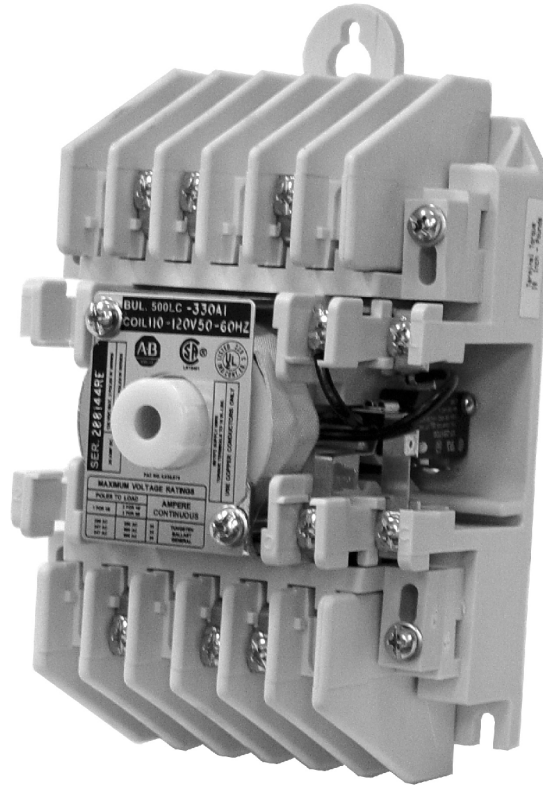

# Installing Bulletin 500LC Lighting Contactors

Use these instructions to install Bulletin 500LC Lighting Contactors.



**CAUTION**



To avoid personal injury de-energize the branch circuit and the control line to be connected to the Bulletin 500LC Lighting Contactor.

## Drawing Index

Drawing Description	Bulletin 500LC Lighting Contactor containing all N/O Contacts	Bulletin 500LC Lighting Contactor containing N/O & N/C Contacts	Page
Enclosure Mounting – Type 1	A	A	5
Enclosure Mounting – Type 3R, 4/4X, & 12	B	B	5
Open-Type Outline & Mounting	C	D	6
Outline & Mounting with Accessories	E	F	7, 8
Wiring Diagram	page 11	page 12	11, 12
Wiring Diagram with Accessories	page 13	page 14	13, 14

## Ratings

Bulletin 500LC Lighting Contactors are rated for 20 amps lighting loads and 30 amps general purpose. They are UL508 Listed, CSA Certified, and are available in 2-...12-pole single throw double break and 2-...6-pole normally open and normally closed configurations. Control voltages are from 120...480V AC. See Tables A, B, and C for contact ratings.

**Table A – Maximum AC Voltage and Amp. Ratings For Bulletin 500LC Main Contacts (open or closed)**

Load Type	Amperes Continuous	Poles to Load	
		1 for 1 $\phi$	2 for 1 $\phi$ 3 for 3 $\phi$
Tungsten	20	250V AC	250V AC
Ballast	20	347V AC	600V AC
General	30	347V AC	600V AC

**Table B – Maximum DC Voltage and Amp. Ratings For Bulletin 500LC Main Contacts (open or closed)**

Load Type	Amperes Continuous	Poles to Load	
		2 in Series	3 in Series
General	20	125V DC	250V DC

**Table C – Withstand Current Ratings For Bulletin 500LC Lighting Contactors (when applying to UL67 Listed Panelboard)**

Available Symmetrical Amperes RMS		
At AC Service Voltage	When Used with Molded-Case Circuit Breakers	
	Withstand Current Rating (amps)	Maximum Breaker Size (amps)
250V	22,000	30
480V	14,000	30
600V	10,000	30

## Catalog Number Explanation\*

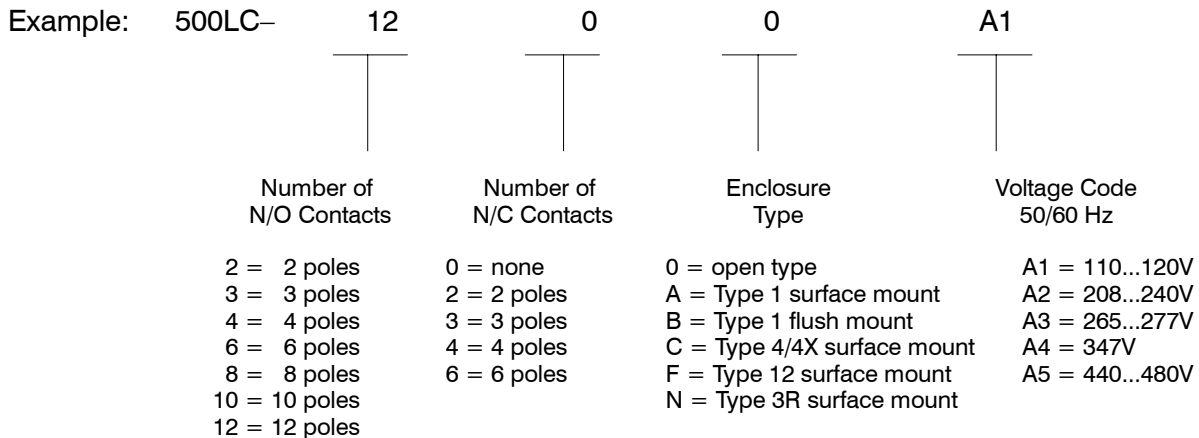

\*Note: Contactor will accommodate a maximum of 12 contacts.

## Installation

Bulletin 500LC Lighting Contactors are tested and ready to use. Installation simply requires mounting, and connection of line and load circuits and control circuit wires.

## Mounting

Six outline and mounting drawings are furnished in this manual. Use Drawing A (page 5 top) for 500LC supplied in a surface or flush Type 1 enclosure. Use Drawing B (page 5 bottom) for 500LC supplied in a Type 3R, 4/4X, or 12 enclosure. Four outline and mounting drawings show how to install open-type 500LC. Use Drawing C (page 6 top) for Bulletin 500LC Lighting Contactors containing all N/O contacts. Use Drawing D (page 6 bottom) for Bulletin 500LC Lighting Contactors containing both N/O & N/C contacts. Use Drawing E (page 7) for Bulletin 500LC Lighting Contactors containing all N/O contacts supplied with optional field installed modifications. Use Drawing F (page 8 top) for Bulletin 500LC Lighting Contactors containing both N/O & N/C contacts with optional field installed modifications. The diagrams show all mounting details and instructions.

### ATTENTION



Protect the unit from construction grit and metal chips.

The Bulletin 500LC Lighting Contactor can be mounted in any position but is usually mounted vertically. Mounting holes in open-type 500LC accept #10 screws (3/8-inch minimum length). Enclosure mounting holes accept 1/4-inch diameter screws.

## Line and Load Connections

### CAUTION



To avoid personal injury de-energize the branch circuit and the control line to be connected to the unit

Four Wiring Diagrams are furnished. Use the diagram on page 11 for Bulletin 500LC Lighting Contactors containing all N/O contacts. Use the diagram on page 12 for Bulletin 500LC Lighting Contactors containing both N/O & N/C contacts. Use the diagram on page 13 for Bulletin 500LC Lighting Contactors containing all N/O contacts supplied with optional field installed modifications. Use the diagram on page 14 for Bulletin 500LC Lighting Contactors containing both N/O & N/C contacts supplied with optional field installed modifications.

Line and load terminals are reversible. The Bulletin 500LC Lighting Contactor is UL Listed for use with 60 or 75° C wire. All power wires should enter enclosure adjacent to the 500LC terminals. Combination knockouts are provided on Type 1 enclosures. Line and load connections are supplied with clamp type terminals. These terminals accept the wire sizes #18–10 AWG Cu. Insert appropriate line and load wires and tighten clamp screws to 18 inch–pounds.

## Control Line Connections

Control circuit connections designated L, O, C on the right side are supplied with clamp type terminals. These terminals accept wire sizes #18–10 AWG Cu. Simply insert appropriate control wires and tighten terminal clamp screws to 18 inch–pounds. See the wiring diagrams.

### ATTENTION



Install overcurrent protective devices for the control circuit in accordance with applicable electrical codes.

Table D lists the maximum distances and minimum wire sizes that can be run between a control station and one Bulletin 500LC.

**Table D – Control Line Run**

Wire Size (AWG)	Maximum Distance (feet) at AC control voltage				
	120V	240V	277V	347V	480V
14	1,050	3,100	4,100	5,600	8,800
12	1,670	5,000	6,600	9,000	14,000
10	2,650	8,000	10,600	14,000	22,000

### ATTENTION



Do not exceed these distances for proper unit operation.

Table E lists the Bulletin 500LC Lighting Contactor's coil inrush current and minimum control circuit fuse sizes.

**Table E – Inrush Current / Minimum Fuse**

Inrush Current Over Fuse Size (amps RMS) at AC control voltage					
Amps	120V	240V	277V	347V	480V
inrush	5.0	2.5	2.2	1.8	1.3
fuse	2.0	1.0	1.0	0.75	0.5

## Type 1 Surface & Flush Enclosed Units — Drawing A

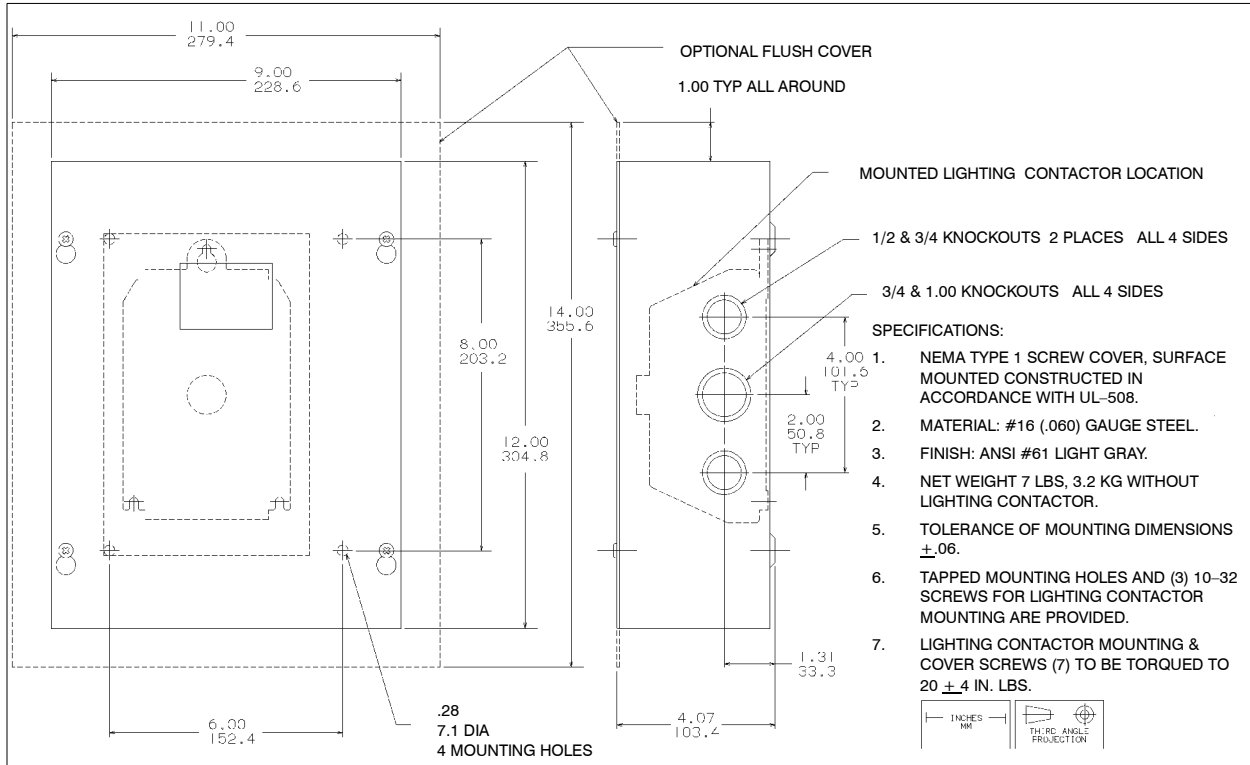

## Type 3R, 4/4X, & 12 Enclosed Units — Drawing B

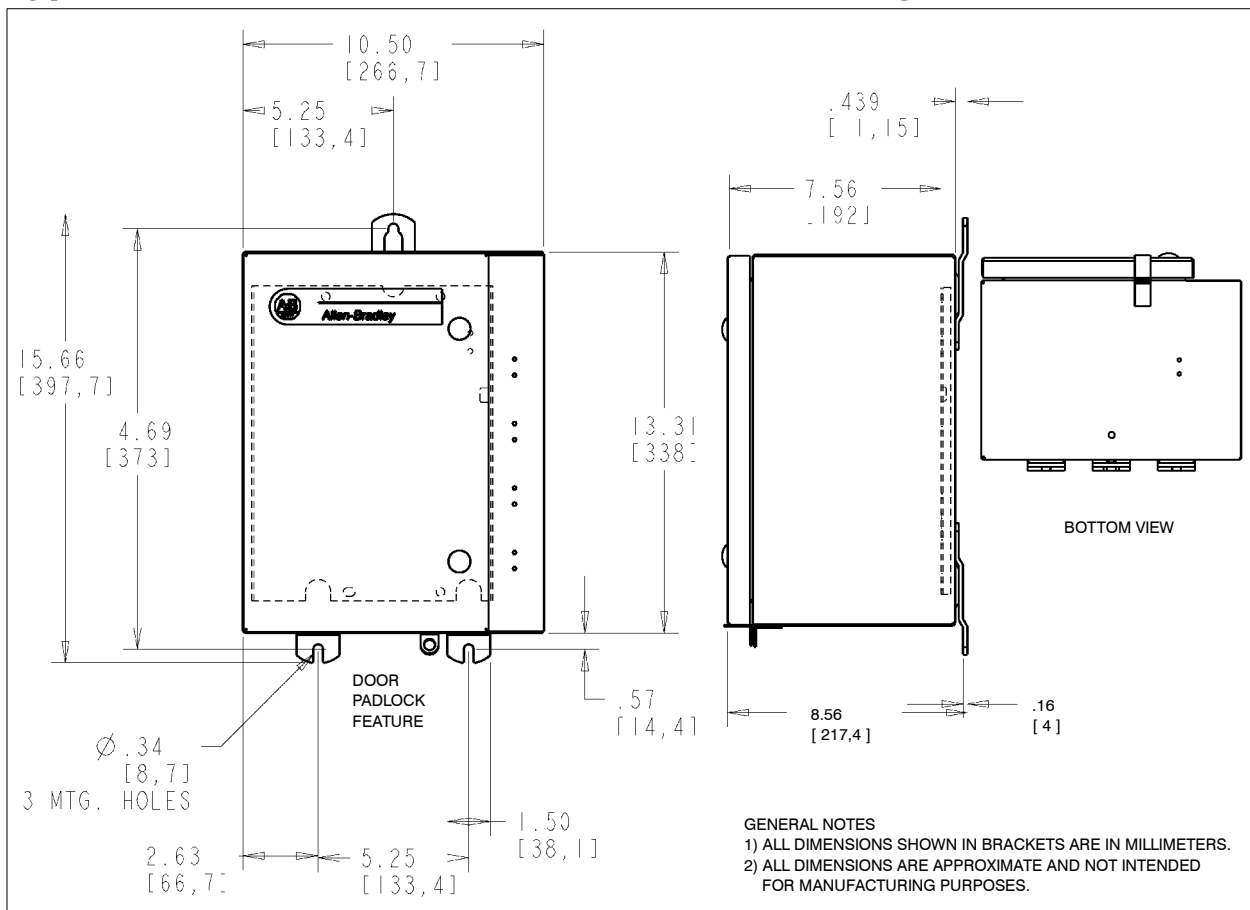

# Bulletin 500LC Lighting Contactors containing all N/O contacts — Drawing C

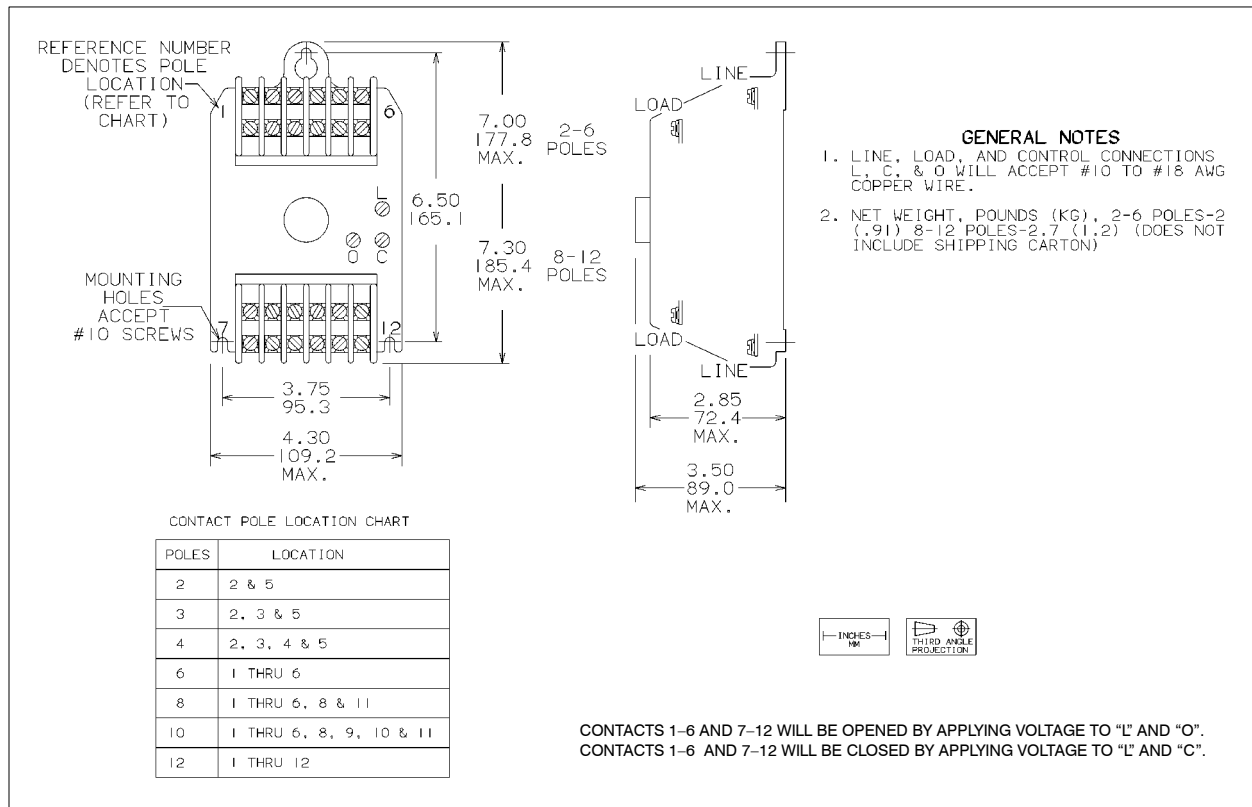

# Bulletin 500LC Lighting Contactors containing both N/O & N/C contacts — Drawing D

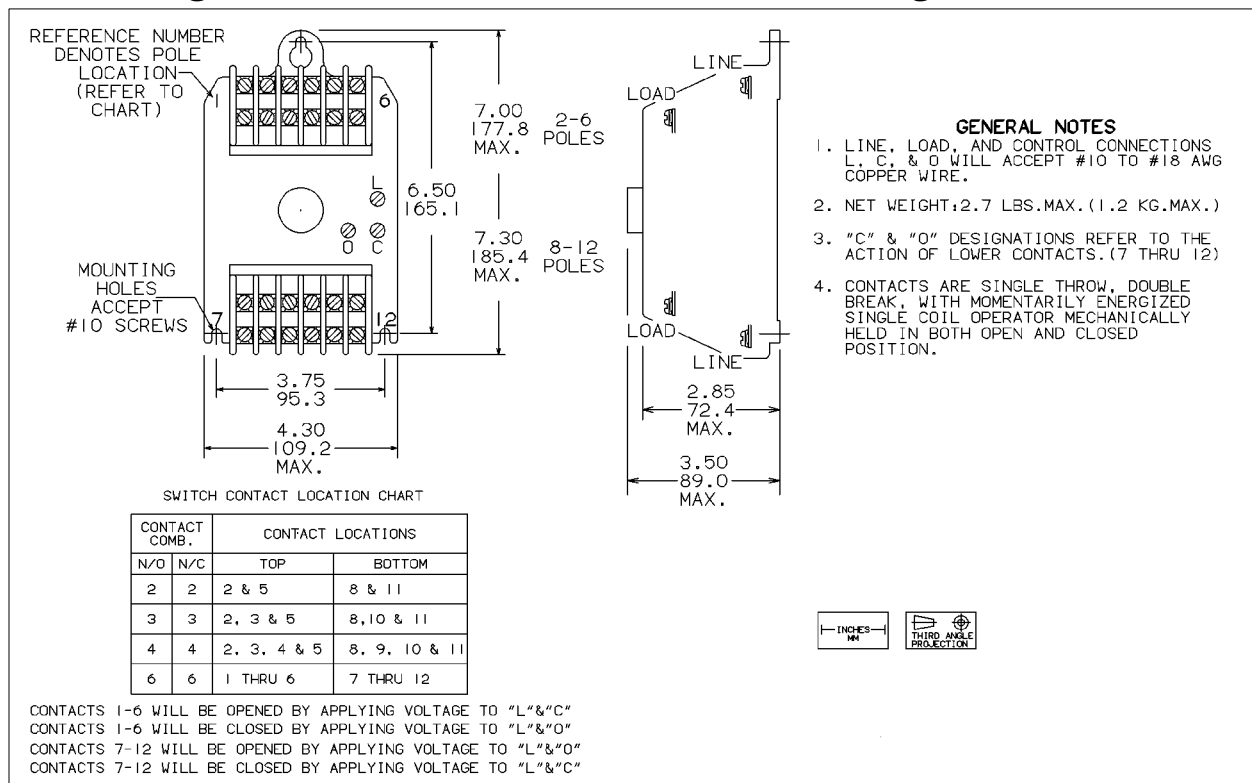

# Bulletin 500LC Lighting Contactor containing all N/O contacts Field Installed Modifications — Drawing E

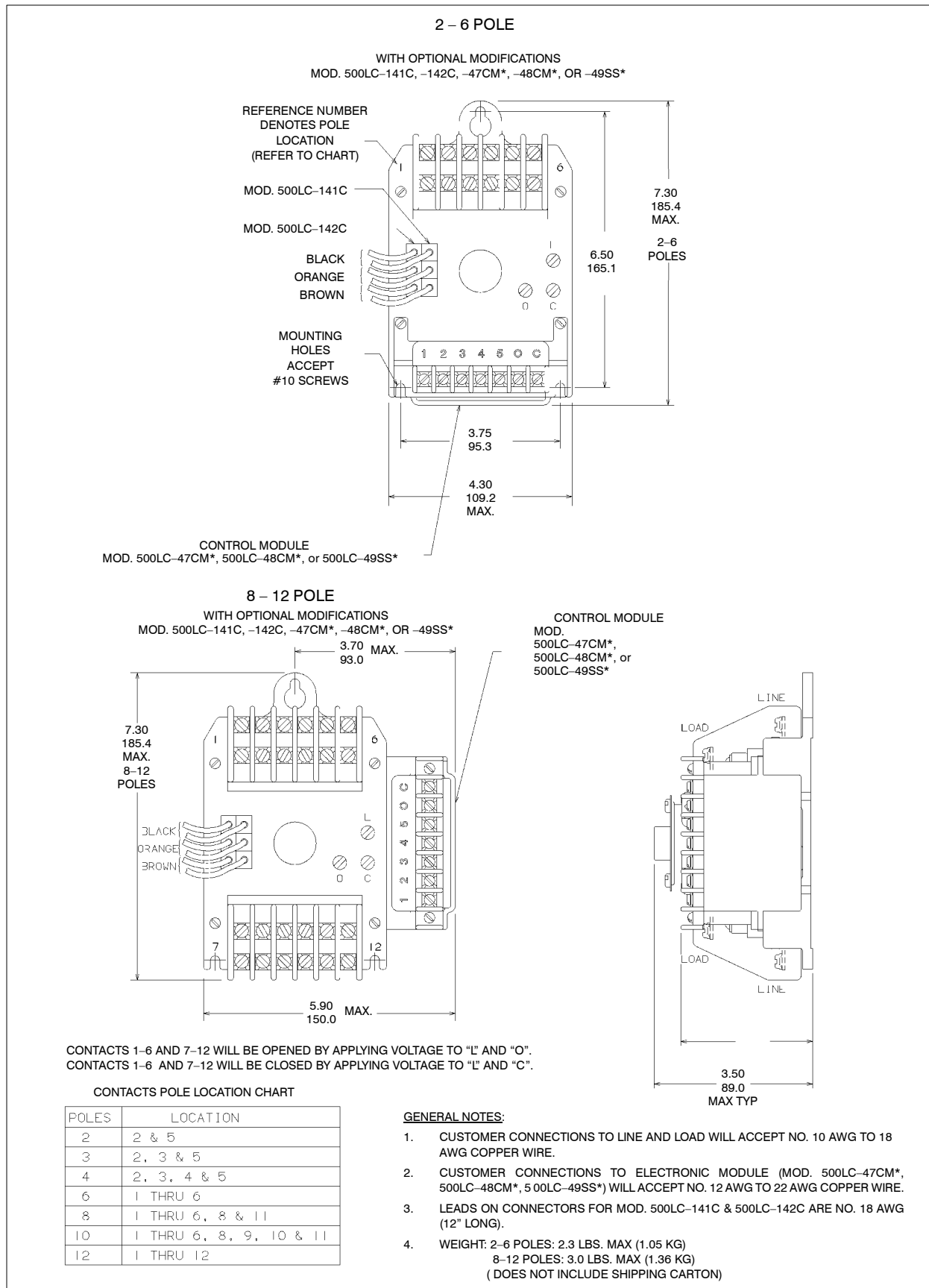

# Bulletin 500LC Lighting Contactor containing N/O & N/C contacts Field Installed Modifications — Drawing F

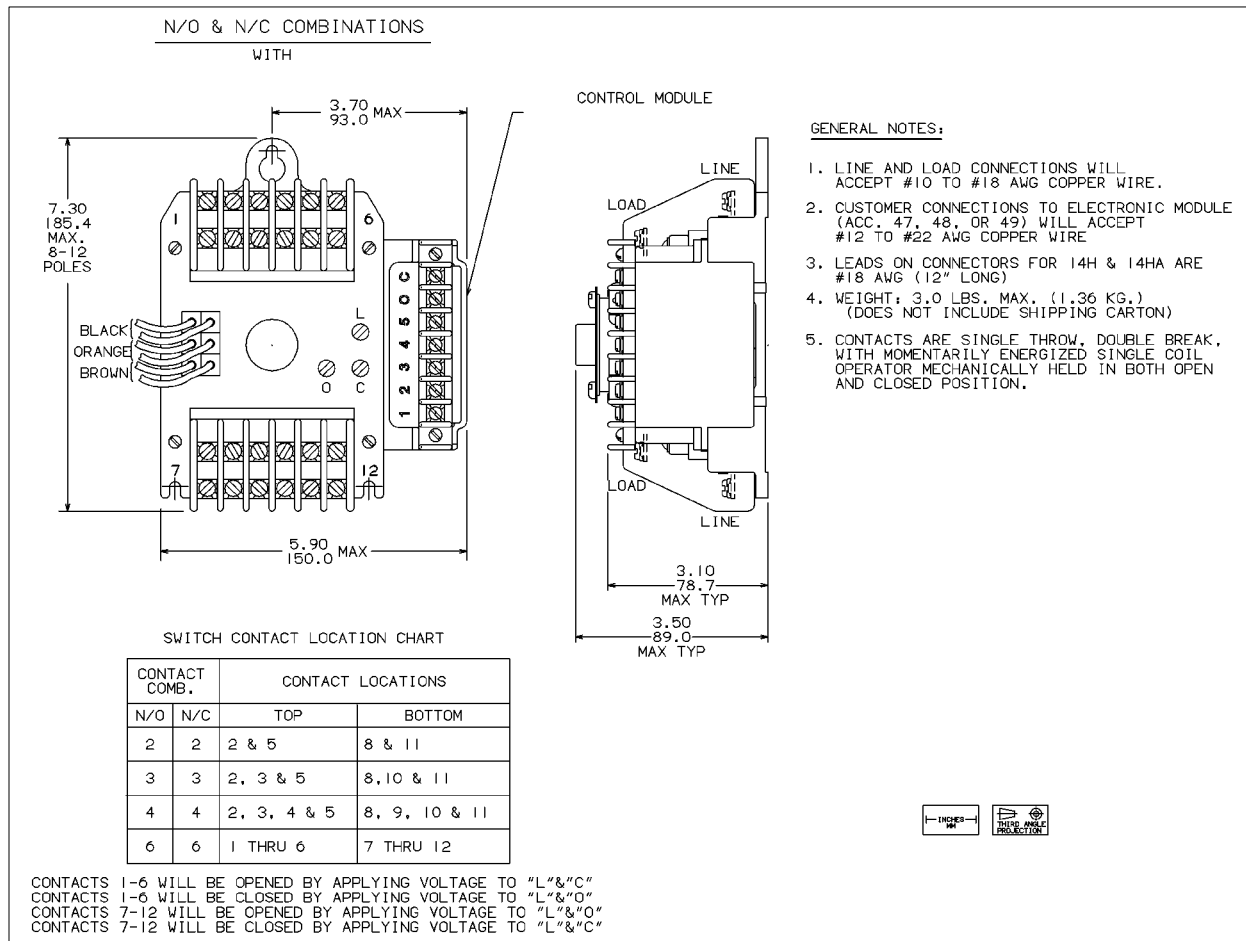

## Kits

Kits are available for modification of Bulletin 500LC Lighting Contactors to allow changes in pole configuration, voltage, control modules, and auxiliary contacts.

## Replacement Parts

The main contact blocks and the operator coil are available in kit form. When ordering parts, provide the Serial No. and Catalog No. from the Bulletin 500LC Lighting Contactor nameplate.

## Auxiliary Contacts Kit – Optional Field Installed Modification 500LC-141C, 500LC-142C

These auxiliary contacts are to be installed on the left side of the Bulletin 500LC. The auxiliary contacts operate along with the main contacts to provide remote indication of the 500LC position (closed or open).

Each auxiliary contact provides a form C, spdt (single pole double throw) contact rated 10 amps at 277V AC. Mod. 500LC-141C is one auxiliary contact, and Mod. 500LC-142C is two auxiliary contacts. A connector with leads is provided for each auxiliary contact See wiring diagram on page 13 or 14 for contact configuration, additional ratings, and wiring.



## Solid-state Control Modules – Field Installed Modifications

### 500LC–47CM\*, 500LC–48CM\*, 500LC–49SS\*

These control modules are to be connected and mounted on the bottom or right side of the Bulletin 500LC Lighting Contactor depending on the number of 500LC poles or N/O and N/C contact configuration. A control module can be field installed by ordering the appropriate module kit. Refer to wiring diagrams on page 13 or 14.

#### Operation

**Mod. 500LC–47CM\*** control modules are for two-wire control of the Bulletin 500LC only. The module must be energized to close the 500LC, and de-energized to open the 500LC. Therefore, use a single pole, maintained type control station to operate the control module.

**Mod. 500LC–48CM\*** control modules are for three-wire control of the Bulletin 500LC. One terminal must be energized to close the 500LC; another terminal must be energized to open the 500LC. If neither or both terminals are energized, no output will occur. Therefore, use a single pole, double throw, momentary type control station to operate the control module.

**Mod. 500LC–49SS\*** control modules are for Form 3 (start-stop) control of the Bulletin 500LC. The modules must be energized to close the 500LC, and de-energized to open the 500LC. Therefore, use one normally-closed and one normally-open separate control stations to operate the control module.

There are four different control modules for each Mod. 500LC–47CM\*, 500LC–48CM\*, and 500LC–49SS\*. Each module is suitable only for the control voltage marked on it. Refer to Table F. Ratings for the control modules are listed in Table H.

**Table F – Solid-State Control Module numbers**

Module Control Voltage	2-Wire Control Modules	3-Wire Control Modules	Form 3 Control Modules
120V AC	500LC–47CM120	500LC–48CM120	500LC–49SS120
24V AC & DC	500LC–47CM24	500LC–48CM24	500LC–49SS24
240 / 277V AC	500LC–47CM240	500LC–48CM240	500LC–49SS240
12V AC & DC	500LC–47CM12	500LC–48CM12	500LC–49SS12

#### Connections

Connections to the Mod. 500LC–47CM\*, 500LC–48CM\*, and 500LC–49SS\* control modules are shown in Table G. Also refer to the labels in Figure 1 and to wiring diagram on page 13 or 14. Barrier screw type terminals accept #22–12 AWG Cu control wiring. Tighten terminals to 12 inch-pounds.

The control modules have two colored leads preconnected to the **O** and **C** terminal bus on the 500LC. A yellow wire runs between the **O** terminals; and orange/black wire runs between the **C** terminals.

Connect your control wiring for the module to terminals **2**, **3**, and **4** on the modules. Terminal **2** is not used on Mod. 500LC–47CM\* and terminal **1** is never used.

Connect your control wiring for the 500LC Lighting Contactor (coil voltage) to terminal **5** on the control module and terminal **L** on the 500LC. If the line voltage (service) is the same as the coil voltage, the control voltage can come directly from the poles of the 500LC Lighting Contactor.

ATTENTION



For DC modules be sure to connect terminal 4 to negative (-).

**Table G – Connections to Solid-State Control Modules**

Module Terminal	Connected To
1	not used
2	control station for Mod. 500LC-48CM*, 500LC-49SS*
3	control station for Mod. 500LC-47CM*, 500LC-48SS*, 500LC-49SS*
4	Control Module control voltage*
5	500LC Lighting Contactor control voltage
O	pre-connected to O on 500LC Lighting Contactor
C	pre-connected to C on 500LC Lighting Contactor

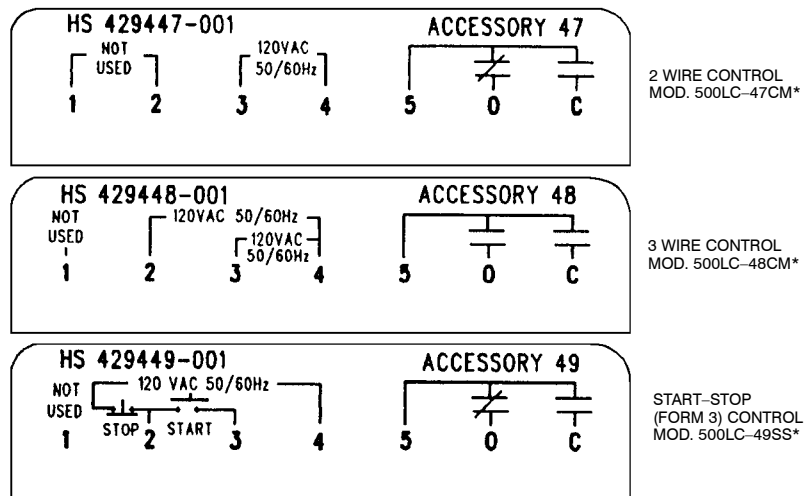

**Figure 1 Typical labels on control modules**

**Table H – Ratings for Control Modules**

Nominal Input Voltage . see Table F, AC voltages are 50/60 Hz  
 Control Voltage Range . . . . . 80...125% of nominal  
 Ambient Temperature Range Operate . . . . . 0° ... +45° C  
 Ambient Temperature Range Storage . . . . . -30° ... +65° C

Control Module	Mod. 500LC-47CM*		Mod. 500LC-48CM*		Mod. 500LC-49SS*	
	AC	DC	AC	DC	AC	DC
120V AC	1.90	—	1.60	—	3.70	—
24V AC & DC	0.85	0.36	0.34	0.38	0.70	0.72
240 / 277V AC	4.00	—	2.50	—	6.00	—
12V AC & DC	0.60	0.32	0.34	0.36	0.68	0.70

# Bulletin 500LC Lighting Contactors containing all N/O contacts

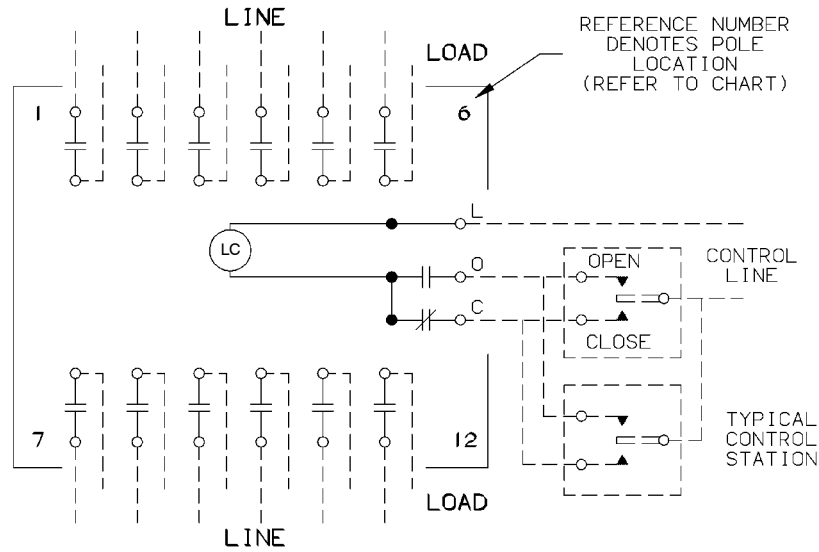

CONTACT POLE LOCATION CHART

POLES	LOCATION
2	2 & 5
3	2, 3 & 5
4	2, 3, 4 & 5
6	1 - 6
8	1 - 6, 8 & 11
10	1-6,8,9,10 & 11
12	1 - 12

MAIN CONTACTS MAXIMUM VOLTAGE RATINGS OPEN OR CLOSED

POLES TO LOAD		AMPERE CONTINUOUS	
1 FOR 1Ø	2 FOR 1Ø 3 FOR 3Ø		
250 AC	250 AC	20	TUNGSTEN
347 AC	600 AC	20	BALLAST
347 AC	600 AC	30	GENERAL

20 AMP. DC GENERAL	125V DC MAX. 2 POLES IN SERIES
	250V DC MAX. 3 POLES IN SERIES

**BULLETIN 500LC LIGHTING CONTACTOR (WHEN USED WITH UL67 LISTED PANELBOARD) IS SUITABLE FOR USE IN A CIRCUIT CAPABLE OF DELIVERING NOT MORE THAN THE RMS SYMMETRICAL CURRENT AT THE MAXIMUM VOLTAGE SHOWN BELOW, WHEN PROTECTED BY A 30 AMP CIRCUIT BREAKER HAVING AN INTERRUPTING RATING NOT LESS THEN VALUES SHOWN.**

MAX. RMS AMPERES	MAX. AC VOLTS
22000	250
14000	480
10000	600

### GENERAL NOTES

- WHEN RC COIL AND LINE VOLTAGE ARE THE SAME THE RC CONTROL VOLTAGE CAN BE DERIVED FROM THE LINE POLES OF THE RC SWITCH.
- MAIN CONTACTS ARE SHOWN IN OPEN POSITION WITH CONTROL LINE DE-ENERGIZED. SEE RATINGS BELOW. (SWITCH SHIPPED WITH CONTACTS CLOSED)
- LINE AND LOAD TERMINALS ARE REVERSIBLE.
- CONTACTS ARE SINGLE THROW, DOUBLE BREAK, WITH MOMENTARILY ENERGIZED SINGLE COIL OPERATOR MECHANICALLY HELD IN BOTH OPEN AND CLOSED POSITIONS.
- CUSTOMER CONNECTIONS TO LINE AND LOAD WILL ACCEPT NO.10 AWG. TO 18 AWG. COPPER WIRE.

# Bulletin 500LC Lighting Contactors containing both N/O & N/C contacts

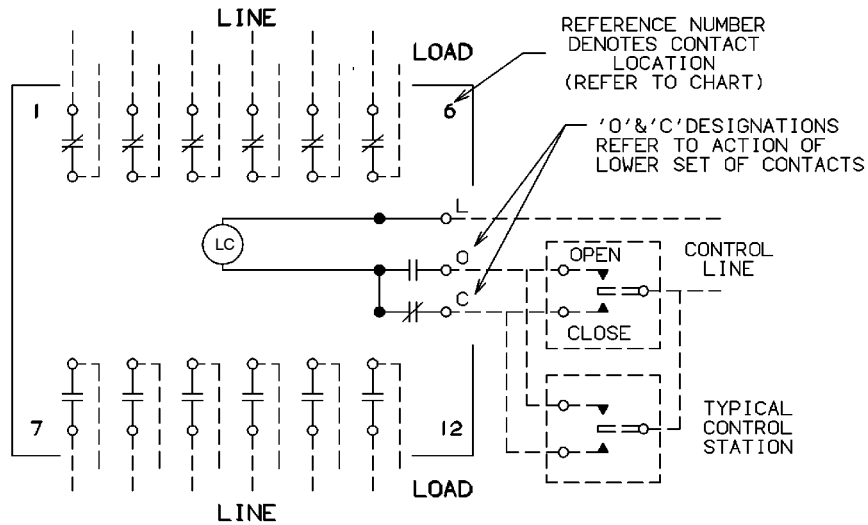

BULLETIN 500LC LIGHTING CONTACTOR (WHEN USED WITH UL67 LISTED PANELBOARD)  
IS SUITABLE FOR USE IN A CIRCUIT CAPABLE OF DELIVERING NOT MORE THAN THE RMS SYMMETRICAL CURRENT AT THE MAXIMUM VOLTAGE SHOWN BELOW, WHEN PROTECTED BY A 30 AMP. CIRCUIT BREAKER HAVING AN INTERRUPTING RATING NOT LESS THAN VALUES SHOWN.

	MAX. RMS AMPERES	MAX. AC VOLTS
	22000	250
	14000	480
	10000	600

SWITCH CONTACT LOCATION CHART

CONTACT COMB.		CONTACT LOCATIONS	
N/O	N/C	TOP	BOTTOM
2	2	2 & 5	8 & 11
3	3	2, 3 & 5	8, 10 & 11
4	4	2, 3, 4 & 5	8, 9, 10 & 11
6	6	1 THRU 6	7 THRU 12

MAIN CONTACTS MAXIMUM VOLTAGE RATINGS OPEN OR CLOSED

POLES TO LOAD		AMPERE CONTINUOUS	
1 FOR 1Ø	2 FOR 1Ø 3 FOR 3Ø		
250 AC	250 AC	20	TUNGSTEN
347 AC	600 AC	20	BALLAST
347 AC	600 AC	30	GENERAL
20AMP DC GENERAL	125VDC <sub>MAX</sub>	2 POLES IN SERIES	
	250VDC <sub>MAX</sub>	3 POLES IN SERIES	

CONTACTS 1-6 WILL BE OPENED BY APPLYING VOLTAGE TO "L"&"C"  
CONTACTS 1-6 WILL BE CLOSED BY APPLYING VOLTAGE TO "L"&"O"  
CONTACTS 7-12 WILL BE OPENED BY APPLYING VOLTAGE TO "L"&"O"  
CONTACTS 7-12 WILL BE CLOSED BY APPLYING VOLTAGE TO "L"&"C"

### GENERAL NOTES

- WHEN LC COIL AND LINE VOLTAGE ARE THE SAME THE LC CONTROL VOLTAGE CAN BE DERIVED FROM THE LINE POLES OF THE RC SWITCH.
- MAIN CONTACTS ARE SHOWN WITH LOWER CONTACTS IN OPEN POSITION WITH CONTROL LINE DE-ENERGIZED. (SWITCH SHIPPED WITH LOWER CONTACTS IN CLOSED POSITION)
- LINE AND LOAD TERMINALS ARE REVERSIBLE.
- CONTACTS ARE SINGLE THROW, DOUBLE BREAK, WITH MOMENTARILY ENERGIZED SINGLE COIL OPERATOR MECHANICALLY HELD IN BOTH OPEN AND CLOSED POSITIONS.
- LINE, LOAD AND CONTROL CONNECTIONS L, C & O WILL ACCEPT NO.10 AWG. TO 18 AWG. COPPER WIRE.

# Bulletin 500LC Lighting Contactors containing all N/O contacts with Field Installed Modifications

**OPTIONAL AUXILIARY CONTACTS**

**2-6 POLES**

REFERENCE NUMBER DENOTES POLE LOCATION (REFER TO CHART)

MOD. 500LC-47CM\*, 500LC-48CM\*, or 500LC-49SS\*

**AUXILIARY CONTACT RATING**

10A, 1/3 HP  
277 VAC  
0.5A, 125 VDC  
0.25A, 250 VDC

500LC-141C (1PDT)  
500LC-142C (2PDT)

**CONTACT POLE LOCATION CHART**

POLES	LOCATION
2	2 & 5
3	2, 3 & 5
4	2, 3, 4 & 5
6	1 - 6
8	1 - 6, 8 & 11
10	1 - 6, 8, 9, 10 & 11
12	1 - 12

**MAIN CONTACT MAXIMUM VOLTAGE RATINGS OPEN OR CLOSED**

POLES TO LOAD		AMPERE CONTINUOUS	
1 FOR 1Ø	2 FOR 1Ø	3 FOR 3Ø	
250 AC	250 AC	20	TUNGSTEN
347 AC	600 AC	20	BALLAST
347 AC	600 AC	30	GENERAL

20 AMP. DC GENERAL	125V DC MAX. 2 POLES IN SERIES
	250V DC MAX. 3 POLES IN SERIES

**OPTIONAL AUXILIARY CONTACTS**

**8-12 POLES**

MOD. 500LC-47CM\*, 500LC-48CM\*, or 500LC-49SS\*

**2 WIRE CONTROL MOD. 500LC-47CM\***

**3 WIRE CONTROL MOD. 500LC-48CM\***

**START-STOP (FORM 3) CONTROL MOD. 500LC-49SS\***

**GENERAL NOTES**

- WHEN 500LC COIL AND LINE VOLTAGE ARE THE SAME THE 500LC CONTROL VOLTAGE CAN BE DERIVED FROM THE LINE POLES OF THE 500LC LIGHTING CONTACTOR.
- MAIN CONTACTS ARE SHOWN IN OPEN POSITION WITH CONTROL LINE DE-ENERGIZED. SEE RATINGS BELOW. (500LC SHIPPED WITH CONTACTS CLOSED)
- LINE AND LOAD TERMINALS ARE REVERSIBLE.
- CONTACTS ARE SINGLE THROW, DOUBLE BREAK, WITH MOMENTARILY ENERGIZED SINGLE COIL OPERATOR MECHANICALLY HELD IN BOTH OPEN AND CLOSED POSITIONS.
- INDICATES CUSTOMER CONNECTION POINTS.  
● INDICATES FACTORY CONNECTION POINTS.
- CONNECTION POINTS THAT HAVE BOTH CUSTOMER AND FACTORY CONNECTIONS ARE SHOWN AS CUSTOMER CONNECTIONS.
- CUSTOMER CONNECTIONS TO LINE AND LOAD WILL ACCEPT NO 10 AWG TO 18 AWG COPPER WIRE.
- CUSTOMER CONNECTIONS TO ELECTRONIC MODULE MOD. 500LC-47CM\*, 500LC-48CM\*, 500LC-49SS\* WILL ACCEPT NO. 12 AWG TO 22 AWG COPPER WIRE.
- LEADS ON CONNECTORS FOR MOD. 500LC-141C & 500LC-142C ARE NO. 18 AWG. (12" LONG).
- CR CONTROL SUPPLIED BY CUSTOMER.

**BULLETIN 500LC LIGHTING CONTACTOR (WHEN USED WITH UL67 LISTED PANELBOARD) IS SUITABLE FOR USE IN A CIRCUIT CAPABLE OF DELIVERING NOT MORE THAN THE RMS SYMMETRICAL CURRENT AT THE MAXIMUM VOLTAGE SHOWN BELOW, WHEN PROTECTED BY A 30 AMP CIRCUIT BREAKER HAVING AN INTERRUPTING RATING NOT LESS THEN VALUES SHOWN.**

MAXIMUM RMS		MAXIMUM AC	
AMPERES		VOLTS	
22,000		250	
14,000		480	
10,000		600	

# Bulletin 500LC Lighting Contactors containing both N/O & N/C contacts with Field Installed Modifications

SWITCH CONTACT LOCATION CHART

CONTACT COMB.		CONTACT LOCATIONS	
N/O	N/C	TOP	BOTTOM
2	2	2 & 5	8 & 11
3	3	2, 3 & 5	8, 10 & 11
4	4	2, 3, 4 & 5	8, 9, 10 & 11
6	6	1 THRU 6	7 THRU 12

AUXILIARY CONTACT RATING  
 10A, 1/3 HP  
 277 VAC  
 0.5A, 125 VDC  
 0.25A, 250 VDC  
 500LC-141C (1PDT)  
 500LC-142C (2PDT)

CONTACTS 1-6 WILL BE OPENED BY APPLYING VOLTAGE TO "L"&"C"  
 CONTACTS 1-6 WILL BE CLOSED BY APPLYING VOLTAGE TO "L"&"O"  
 CONTACTS 7-12 WILL BE OPENED BY APPLYING VOLTAGE TO "L"&"O"  
 CONTACTS 7-12 WILL BE CLOSED BY APPLYING VOLTAGE TO "L"&"C"

MAIN CONTACT MAXIMUM VOLTAGE RATINGS OPEN OR CLOSED

POLES TO LOAD		AMPERE CONTINUOUS	
1 FOR 1Ø	2 FOR 1Ø 3 FOR 3Ø	20	TUNGSTEN
250 AC	250 AC	20	BALLAST
347 AC	600 AC	30	GENERAL
347 AC	600 AC		

20 AMP. DC GENERAL	125V DC MAX. 2 POLES IN SERIES
	250V DC MAX. 3 POLES IN SERIES

BULLETIN 500LC LIGHTING CONTACTOR (WHEN USED WITH UL67 LISTED PANELBOARD) IS SUITABLE FOR USE IN A CIRCUIT CAPABLE OF DELIVERING NOT MORE THAN THE RMS SYMMETRICAL CURRENT AT THE MAXIMUM VOLTAGE SHOWN BELOW, WHEN PROTECTED BY A 30 AMP CIRCUIT BREAKER HAVING AN INTERRUPTING RATING NOT LESS THEN VALUES SHOWN.

MAXIMUM RMS		MAXIMUM AC	
AMPERES	VOLTS	AMPERES	VOLTS
22,000	250	14,000	480
10,000	600		

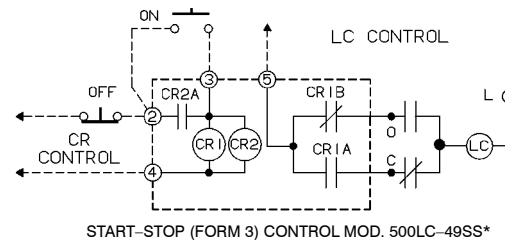
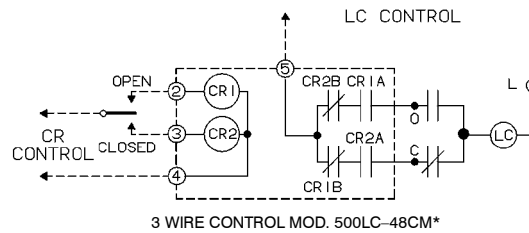
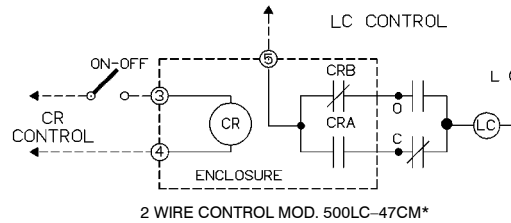
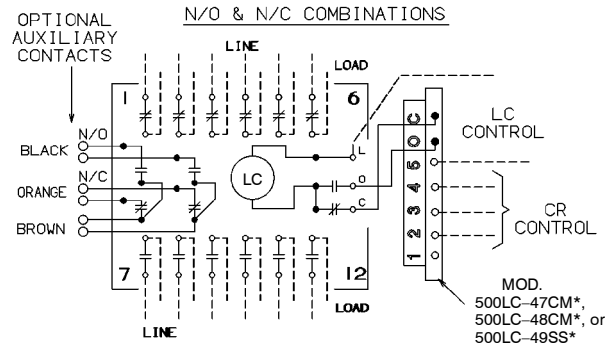

## GENERAL NOTES

- WHEN 500LC COIL AND LINE VOLTAGE ARE THE SAME THE 500LC CONTROL VOLTAGE CAN BE DERIVED FROM THE LINE POLES OF THE 500LC LIGHTING CONTACTOR.
- MAIN CONTACTS ARE SHOWN WITH LOWER CONTACTS IN OPEN POSITION WITH CONTROL LINE DE-ENERGIZED. (500LC SHIPPED WITH LOWER CONTACTS IN CLOSED POSITION.)
- LINE AND LOAD TERMINALS ARE REVERSIBLE.
- CONTACTS ARE SINGLE THROW, DOUBLE BREAK, WITH MOMENTARILY ENERGIZED SINGLE COIL OPERATOR MECHANICALLY HELD IN BOTH OPEN AND CLOSED POSITIONS.
- INDICATES CUSTOMER CONNECTION POINTS. ● INDICATES FACTORY CONNECTION POINTS.
- CONNECTION POINTS THAT HAVE BOTH CUSTOMER AND FACTORY CONNECTIONS ARE SHOWN AS CUSTOMER CONNECTIONS.
- CUSTOMER CONNECTIONS TO LINE AND LOAD WILL ACCEPT NO 10 AWG TO 18 AWG COPPER WIRE.
- CUSTOMER CONNECTIONS TO ELECTRONIC MODULE MOD. 500LC-47CM\*, 500LC-48CM\*, 500LC-49SS\* WILL ACCEPT NO. 12 AWG TO 22 AWG COPPER WIRE.
- LEADS ON CONNECTORS FOR MOD. 500LC-141C & 500LC-142C ARE NO. 18 AWG. (12" LONG).
- CR CONTROL SUPPLIED BY CUSTOMER.

**CAUTION**

The Bulletin 500LC Lighting Contactor is energized. Proceed with care!

## Trouble-Shooting

Problem	Check Control Voltage	Check Control Station, Wiring, Supply
500LC does not close when control station is closed.	Measure control voltage between 500LC terminals L and C.	If no voltage is present, check control station contacts, control wiring, supply fuses, and optional accessories.
500LC does not open when control station is closed.	Measure control voltage between 500LC terminals L and O.	If no voltage is present, check control station contacts, control wiring, supply fuses, and optional accessories.
500LC tries to close or open, but cannot.	Measure at least 90% control voltage (nameplate coil voltage) between 500LC terminals L and C, or L and O.	If voltage is low, check control wire size and line run distance; see Table D on page 4. If a transformer is used in the control line, make sure it can handle the VA burden required; see Table E on page 4.
500LC closes and opens repeatedly.	—	Check control station for overlapping contacts, and correct. Control stations cannot call on 500LC to close and open at the same time.
500LC closes or opens very quickly with excessive noise.	Measure no more than 110% control voltage (nameplate coil voltage) between 500LC terminals L and C, or L and O.	If voltage is high, change control supply or change Bulletin 500LC Lighting Contactor.

## Manual Operation

A #8–32 screw 1–½ in. long can be used to manually operate the 500LC. One is supplied in all replacement parts kits requiring manual operation. The screw should be used for maintenance purposes only. Remove the screw after maintenance.

**CAUTION**

Do not manually operate the Bulletin 500LC Lighting Contactor until all power and control circuits are disconnected.

Open circuit breakers, then use a voltmeter to verify no voltage is present at the 500LC at both control and line terminal screws.

Insert the operating screw into the center of the coil and carefully turn it clockwise until the threads engage the cam/core.

Pull the screw outward to open the 500LC contacts; push it in to close the contacts. Observe the buttons in the contact block (buttons out means contacts open).

**[www.rockwellautomation.com](http://www.rockwellautomation.com)**

**Corporate Headquarters**

Rockwell Automation, 777 East Wisconsin Avenue, Suite 1400, Milwaukee, WI 53202-5302 USA, Tel: (1) 414.212.5200, Fax: (1) 414.212.5201

**Headquarters for Allen-Bradley Products, Rockwell Software Products and Global Manufacturing Solutions**

Americas: Rockwell Automation, 1201 South Second Street, Milwaukee, WI 53204-2496 USA, Tel: (1) 414.382.2000, Fax: (1) 414.382.4444  
Europe/Middle East/Africa: Rockwell Automation SA/NV, Vortstaan/Boulevard du Souverain 36, 1170 Brussels, Belgium, Tel: (32) 2 663 0600, Fax: (32) 2 663 0640  
Asia Pacific: Rockwell Automation, Level 14, Core F, Cyberport 3, 100 Cyberport Road, Hong Kong, Tel: (852) 2887 4788, Fax: (852) 2508 1846

**Headquarters for Dodge and Reliance Electric Products**

Americas: Rockwell Automation, 6040 Ponders Court, Greenville, SC 29615-4617 USA, Tel: (1) 864.297.4800, Fax: (1) 864.281.2433  
Europe/Middle East/Africa: Rockwell Automation, Herman-Heinrich-Gossen-Strasse 3, 50858 Köln, Germany, Tel: 49 (0) 2234 379410, Fax: 49 (0) 2234 3794164  
Asia Pacific: Rockwell Automation, 55 Newton Road, #11-01/02 Revenue House, Singapore 307987, Tel: (65) 6356 9077, Fax: (65) 6356 9011

© 2005 Rockwell Automation. All rights reserved. Printed in USA.