

DRAWING FOR 22.00" X 50.00"
NEMA TYPE 4 STAINLESS STL. ENCL.

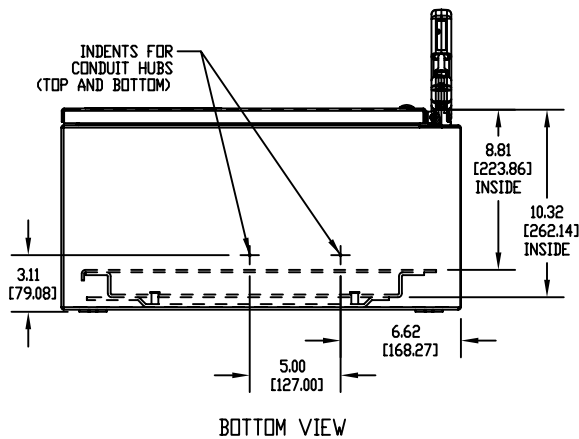
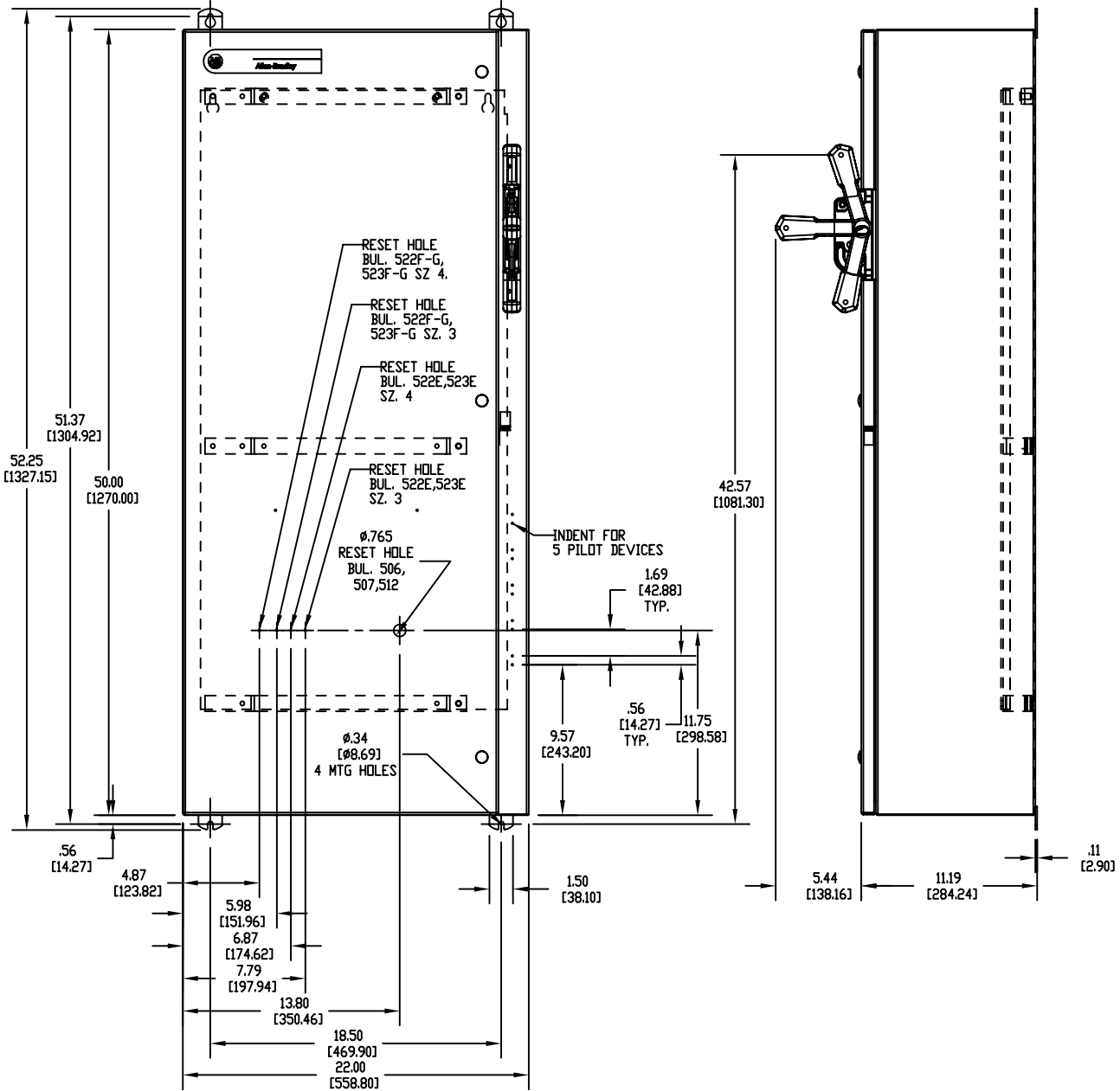

THIS DWG. APPLIES TO:
 BUL. 506 NEMA SIZE 3 & 4
 BUL. 507 NEMA SIZE 3 & 4
 BUL. 512 NEMA SIZE 4
 BUL. 522 NEMA SIZE 3 & 4
 BUL. 523 NEMA SIZE 3 & 4

NOTES:
 1. ALL DIM'S. SHOWN IN PARENTHESES ARE IN MILLIMETERS.
 2. ALL DIM'S. ARE APPROXIMATE AND NOT INTENDED FOR MANUFACTURING PURPOSES