

SECTION A-A

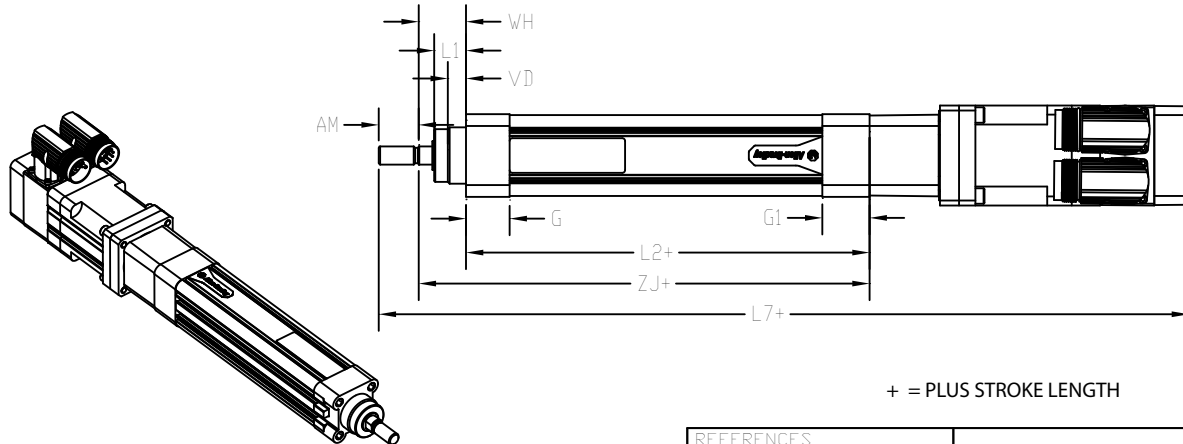

+ = PLUS STROKE LENGTH

REVISION	DATE	BY	APPD.	DESCRIPTION
00				

MPAR-XXXXXX-XXA,ESM	CONFIDENTIAL AND PROPRIETARY INFORMATION THIS DOCUMENT CONTAINS CONFIDENTIAL AND PROPRIETARY INFORMATION OF ROCKWELL AUTOMATION, INC. AND MAY NOT BE USED, COPIED OR DISCLOSED TO OTHERS, EXCEPT WITH THE AUTHORIZED WRITTEN PERMISSION OF ROCKWELL AUTOMATION, INC.
<b>Rockwell Automation</b>	
DR. DP. DATE 11-16-08	SHEET 1 OF 7
CHKD. DATE	DWG. SIZE 10000043888
APPD. DATE	

PARTS MUST CONFORM TO APPLICABLE ROCKWELL AUTOMATION MANUFACTURING STANDARDS	
FILE NAME	10000043888

NOTES:  
1. ALL DIMENSIONS ARE IN MILLIMETERS  
2. TOLERANCES APPLY ONLY WHEN SPECIFIED

CATALOG #	Material Master #	ESE Reference	wt. (kgs)	L7	LB	P	AD	HD	LE	AM	B Ø	D1 Ø	E	G	G1	KK	L1	L2	MM	RT	TG	VD	WH	ZJ ±1	K1	K3
MPAR-A1100B-V2A	PN-41984	MPAR-A1xxxB-VxA	2.55	445.7	126.5				52.4																	
MPAR-A1200B-V2A	PN-41985	MPAR-A1xxxB-VxA	2.88	545.7																						
MPAR-A1300B-V2A	PN-41986	MPAR-A1xxxB-VxA	3.21	645.7																						
MPAR-A1400B-V2A	PN-41987	MPAR-A1xxxB-VxA	3.54	745.7																						
MPAR-A1100E-V2A	PN-41988	MPAR-A1xxxE-VxA	2.98	470.7	151.5				77.2																	
MPAR-A1200E-V2A	PN-41989	MPAR-A1xxxE-VxA	3.31	570.7																						
MPAR-A1300E-V2A	PN-41990	MPAR-A1xxxE-VxA	3.65	670.7																						
MPAR-A1400E-V2A	PN-41991	MPAR-A1xxxE-VxA	3.98	770.7	162.6	55	66.5	94	22	30	16	16	45.5	24	26	M10X1.25	18	122	12	M6	32.5	10	26	148	10	6
MPAR-A1100B-V4A	PN-42019	MPAR-A1xxxB-VxA	2.75	481.8																						
MPAR-A1200B-V4A	PN-42020	MPAR-A1xxxB-VxA	3.08	581.8																						
MPAR-A1300B-V4A	PN-42021	MPAR-A1xxxB-VxA	3.41	681.8																						
MPAR-A1400B-V4A	PN-42022	MPAR-A1xxxB-VxA	3.74	781.8	187.6				85.8																	
MPAR-A1100E-V4A	PN-42023	MPAR-A1xxxE-VxA	3.18	506.8																						
MPAR-A1200E-V4A	PN-42025	MPAR-A1xxxE-VxA	3.51	606.8																						
MPAR-A1300E-V4A	PN-42026	MPAR-A1xxxE-VxA	3.85	706.8																						
MPAR-A1400E-V4A	PN-42027	MPAR-A1xxxE-VxA	4.18	806.8					110.6																	

PARTS MUST CONFORM TO APPLICABLE ROCKWELL AUTOMATION MANUFACTURING STANDARDS	
FILE NAME	10000043888

CONFIDENTIAL AND PROPRIETARY INFORMATION  
THIS DOCUMENT CONTAINS CONFIDENTIAL AND  
PROPRIETARY INFORMATION OF ROCKWELL  
AUTOMATION, INC. AND MAY NOT BE USED,  
COPIED OR DISCLOSED TO OTHERS, EXCEPT  
WITH THE AUTHORIZED WRITTEN PERMISSION OF  
ROCKWELL AUTOMATION, INC.

SHEET	DF
DWG. SIZE	10000043888